

Epson ePOS SDK for Android User's Manual

[Functionality](#)

[How to Use](#)

[API Reference](#)

[Device Specifications](#)

[Sample Programs](#)

[Application Guide](#)

[Appendix](#)

Precautions

- Unauthorized duplication, copying, reproduction, or modification of any part or all of this document is strictly prohibited.
- Contents of this manual are subject to change without prior notice. Contact us directly for the most recent information.
- Every effort is made to ensure that the contents of this manual are without error. Please contact us if any errors or other issues are found.
- The previous statement notwithstanding, we will not be liable for any negative impact as a result of use.
- Epson shall not be liable for any damages caused as a result of using this product incorrectly, failing to comply with the content of this document, or having repair or modifications performed by third parties other than Epson or those specified by Epson.
- Epson shall not be liable for any issues as a result of installing optional parts or consumables that are not genuine Epson parts or parts certified by Epson.

Trademarks

EPSON, EXCEED YOUR VISION, and ESC/POS are registered trademarks of Seiko Epson Corporation.

Android™ is a trademark of Google LLC.

Java™ are trademarks of Oracle Corporation, its subsidiaries, and related companies in the United States and other countries.

Wi-Fi® is a registered trademark of Wi-Fi Alliance®.

The Bluetooth® word mark and logo is a registered trademark of Bluetooth SIG, Inc. Seiko Epson uses these trademarks under the terms of license. Other trademarks and trade names are the property of their respective owners.

QR Code is a registered trademark of Denso Wave Incorporated.

Other company names or product names are trademarks or registered trademarks of their respective companies.

ESC/POS® Command System



Epson has embarked on a global initiative by developing ESC/POS, a unique POS printer command system. ESC/POS contains a wealth of unique commands, many of which are patent-protected. Our system enables the configuration of versatile POS systems with a high level of scalability. In addition to being compatible with most Epson POS printers and displays, the flexibility provided by this unique control system facilitates ease of future upgrades. This functionality and convenience of use are appreciated around the world.

© Seiko Epson Corporation 2015-2020. All rights reserved.

Safety Precautions

Meaning of Symbols

The following symbols are used in this manual. Make sure to understand the meaning of these symbols before using the product.

	Describes usage precautions that must be observed. Incorrect handling due to the disregard of this information may result in product failure or incorrect operation.
	Describes additional explanation or other useful information.

Usage Limitations

Please use our products in environments and systems designed with consideration to safety and disaster recovery such as fail-safe configurations and redundant designs, for example, if this product is used in applications in which a high level of reliability and safety in functionality and precision is required such as in aircraft, trains, ships, automobiles and other transportation-related applications or in crime prevention equipment and safety equipment.

This product is not intended for use in applications that require extremely high levels of reliability and safety such as in aerospace equipment, trunk-line communications equipment, nuclear power control equipment, and medical equipment. Consider your usage environment and requirements carefully before using this product in such applications.

About this Manual

Purpose of this Manual

This manual provides the information necessary to develop applications using Epson ePOS SDK for Android.

Organization of this Manual

This manual is organized into the following chapters.

- Chapter 1 [Functionality](#)
- Chapter 2 [How to Use](#)
- Chapter 3 [API Reference](#)
- Chapter 4 [Device Specifications](#)
- Chapter 5 [Sample Programs](#)
- Chapter 6 [Application Guide](#)
- Appendix [Open Source Software Licensing](#)

Contents

■ Safety Precautions	3
Meaning of Symbols.....	3
■ Usage Limitations	3
■ About this Manual	3
Purpose of this Manual.....	3
Organization of this Manual	3
■ Contents	4

Functionality 11

■ Application Development in Epson ePOS SDK for Android	11
TM Printer Models	12
Customer Display Models.....	12
TM Printer + DM-D30 + barcode scanner model	13
POS Terminal Model	14
■ Epson ePOS SDK for Android Development Environment	15
■ Application Operating Environment	15
Supported printers.....	15
Functions provided in each printer.....	17
Controllable Peripheral Devices	19
■ Downloadable Content	21
■ Web Content	22
■ Limitations	22

How to Use 23

■ Printer Connections	23
■ Creating an Epson ePOS SDK for Android Project	23
■ Programming Guide	27
Programming Flow	27
Effective range of command buffers for setting	33
Status	34

API Reference 35

■ List of ePOS SDK API	35
Printer class.....	35
HybridPrinter class	40
LineDisplay class	43
Keyboard class.....	43
POSKeyboard class.....	44
BarcodeScanner class.....	44

MSR class	44
SimpleSerial class	45
GermanyFiscalElement class	45
OtherPeripheral class	45
CommBox class	46
Common to all classes	46
Discovery class.....	46
Epos2Exception class	46
Log class.....	47
EasySelect class	47
EasySelectInfo class	47

■ **Printer class..... 48**

Printer	48
connect	50
disconnect.....	54
startMonitor	55
stopMonitor.....	56
getStatus.....	57
sendData.....	60
beginTransaction	61
endTransaction.....	62
requestPrintJobStatus	63
clearCommandBuffer.....	64
addTextAlign	65
addLineSpace	66
addTextRotate	67
addText.....	68
addTextLang.....	69
addTextFont.....	70
addTextSmooth.....	71
addTextSize.....	72
addTextStyle.....	73
addHPosition.....	75
addFeedUnit.....	76
addFeedLine.....	77
addImage	78
addLogo.....	82
addBarcode.....	83
addSymbol.....	87
addHLine	92
addVLineBegin	94
addVLineEnd.....	96
addPageBegin.....	97
addPageEnd	98
addPageArea.....	99
addPageDirection.....	101
addPagePosition.....	102
addPageLine.....	104
addPageRectangle	106
addRotateBegin	108
addRotateEnd	110
addCut.....	111
addPulse	112
addSound.....	114
addFeedPosition.....	117
addLayout	118
addCommand.....	122

getMaintenanceCounter.....	123
resetMaintenanceCounter	125
getPrinterSetting	127
setPrinterSetting	130
downloadFirmwareList.....	133
getPrinterFirmwareInfo	135
verifyUpdate.....	137
updateFirmware.....	139
forceRecover.....	142
forcePulse	143
forceStopSound	145
forceCommand.....	146
forceReset.....	147
setStatusChangeEventListeners	148
setReceiveEventListener	150
interval.....	152

■ **HybridPrinter class..... 153**

HybridPrinter.....	153
connect	154
disconnect.....	157
startMonitor	158
stopMonitor.....	159
getStatus.....	160
sendData.....	162
beginTransaction	163
endTransaction.....	164
clearCommandBuffer.....	165
selectPaperType.....	166
waitInsertion	167
cancelInsertion	168
ejectPaper	169
readMicrData.....	170
cleanMicrReader	171
forceRecover.....	172
forcePulse	173
forceCommand.....	175
forceReset.....	176
paperType	177
interval.....	178
waitTime	179
mode40Cpl	180
setStatusChangeEventListeners	181
setReceiveEventListener	183

■ **LineDisplay class..... 186**

LineDisplay.....	186
connect	187
disconnect.....	190
getStatus.....	191
sendData.....	192
clearCommandBuffer.....	193
addInitialize	194
addCreateWindow	195
addDestroyWindow.....	197
addSetCurrentWindow.....	198
addClearCurrentWindow.....	199
addSetCursorPosition	200

addMoveCursorPosition	201
addSetCursorType.....	202
addText.....	203
addReverseText	205
addMarqueeText.....	207
addSetBlink.....	209
addSetBrightness	210
addShowClock.....	211
addCommand.....	212
setReceiveEventListener	213
■ Keyboard class	215
Keyboard	215
connect	216
disconnect.....	218
getStatus.....	219
setPrefix.....	220
getPrefix.....	221
setKeyPressEventListener	222
setReadStringEventListener	223
■ POSKeyboard class.....	224
PosKeyboard	224
connect	225
disconnect.....	227
getStatus.....	228
setKeyPressEventListener	229
■ BarcodeScanner class.....	230
BarcodeScanner	230
connect	231
disconnect.....	234
getStatus.....	235
setScanEventListener	236
■ MSR class.....	237
Msr	237
connect	238
disconnect.....	240
getStatus.....	241
setDataEventListener	242
■ SimpleSerial class	244
SimpleSerial	244
connect	245
disconnect.....	247
getStatus.....	248
sendCommand.....	249
setReceiveEventListener	250
■ GermanyFiscalElement Class	251
GermanyFiscalElement.....	251
connect	252
disconnect.....	256
getStatus.....	257
operate	258
setReceiveEventListener	259
■ OtherPeripheral class.....	261

OtherPeripheral.....	261
connect	262
disconnect.....	264
getStatus.....	265
sendData.....	266
setReceiveEventListener	267
■ CommBox class.....	268
CommBox.....	268
connect	269
disconnect.....	271
getStatus.....	272
getCommHistory	273
sendMessage	275
setReceiveEventListener	277
■ Common to all classes	278
getAdmin.....	278
getLocation.....	279
setConnectionEventListener	280
■ Discovery class	282
start.....	282
stop	286
■ Epos2Exception class	287
getErrorStatus.....	287
■ Log class	288
setLogSettings.....	288
SdkVersion	290
■ EasySelect class.....	291
parseNFC	291
parseQR.....	292
createQR	293
■ EasySelectInfo class	294
deviceType	294
printerName	294
macAddress	294
■ Status list	295
Error Status and countermeasures.....	295
Callback Code and countermeasures.....	297
Printer Status and countermeasures	300
■ Key code list	304
<hr/>	
Device Specifications.....	306
■ List of Supported Classes	306
■ List of Supported APIs.....	309
Printer class.....	309
LineDisplay class.....	320
Common to all classes	325
EasySelect class	327

■ **Printer-specific Support Information 329**

TM-m10.....	329
TM-m30.....	332
TM-m30II.....	335
TM-m30II-H.....	338
TM-T20.....	341
TM-T20II.....	343
TM-T20III.....	346
TM-T20IIIL.....	348
TM-T20X.....	350
TM-T60.....	352
TM-T70.....	354
TM-T70II.....	356
TM-T81II.....	359
TM-T81III.....	361
TM-T82.....	363
TM-T82II.....	365
TM-T82III.....	367
TM-T82IIIL.....	369
TM-T82X.....	371
TM-T83II.....	373
TM-T83III.....	375
TM-T88V.....	378
TM-T88VI.....	380
TM-T100.....	383
TM-U220.....	385
TM-U330.....	386
TM-P20.....	388
TM-P60 (Receipt).....	392
TM-P60 (Peeler).....	394
TM-P60II (Receipt).....	397
TM-P60II (Peeler).....	400
TM-P80.....	403
TM-H6000V.....	406
TM-T20II-i.....	408
TM-T70-i.....	410
TM-T82II-i.....	412
TM-T83II-i.....	414
TM-T88V-i.....	416
TM-T88VI-iHUB.....	418
TM-U220-i.....	421
TM-T70II-DT.....	422
TM-T70II-DT2.....	425
TM-T88V-DT.....	428
TM-T88VI-DT2.....	430
TM-H6000IV-DT.....	432
TM-T88IV.....	434
TM-T90.....	436
TM-L90.....	438
TM-H6000IV.....	441

■ **Usage restriction by firmware version 443**

TM-i Series/TM-DT Series.....	443
TM-m30.....	444
TM-T88VI.....	444
TM-T88VI-iHUB.....	444

Sample Programs445

- **Functionality..... 445**
 - ePOS2Printer445
 - ePOS2 Hybrid Printer446
 - ePOS2Discovery446
 - ePOS2LineDisplay446
 - ePOS2Keyboard447
 - ePOS2POSKeyboard447
 - ePOS2BarcodeScanner.....447
 - ePOS2MSR.....447
 - ePOS2SimpleSerial.....448
 - ePOS2GermanyFiscalElement.....448
 - ePOS2OtherPeripheral449
 - ePOS2CommBox.....449
 - ePOS2EasySelection449
- **Use Environment 450**
- **Installation Procedure 450**

Application Guide.....453

- **To connect via USB 453**
- **To search printers 454**
- **To monitor continuously 455**
- **To use the same printer from multiple mobile devices 457**
- **To specify a transaction..... 458**
- **To reconnect to the network automatically 459**
- **To transmit and receive the data between applications 460**
- **To perform forward printing 462**
- **To select a printer using its NFC tag 464**
- **To select a printer using its QR code..... 466**
- **To perform check process..... 468**
- **To control multiple peripheral devices 470**
- **To control multiple peripheral devices 471**
- **To update the printer firmware version 472**

Appendix473

- **Open Source Software Licensing 473**
 - Sample Programs.....473
 - libraries.....473

Functionality

Epson ePOS SDK for Android is an SDK for developing Android applications. Using Epson ePOS SDK for Android enables the use of simple code to control TM printers. Also, in some TM printers, peripheral devices such as the customer display and barcode scanner that are connected to the printer, and slave printers that are connected over a network can be controlled. In addition, application software using unique functions such as the spooler function and Communication Box, etc. can also be developed.

In this manual, printers are classified as follows.

Type	Description
TM Printers	Collective name for the following receipt printer models: <ul style="list-style-type: none"> • Single-function models • Mobile models • Hybrid models • TM-i Series • TM-DT Series
Slave Printers	A collective name for TM printers connected over a network that are controlled from a smart device via the master TM printer.

Application Development in Epson ePOS SDK for Android

The following section describes the system configurations of applications developed in Epson ePOS SDK for Android.

Refer to the Technical Reference Guide of each printer for information on system configuration methods.

TM Printer Models

This is a system in which a smart device and TM printer are connected through communication.

A connection method (*Bluetooth/Wi-Fi/Ethernet/USB*) conforming to the specifications of your smart device and TM printer can be selected.

Multiple TM printers can be controlled via a Wi-Fi/Ethernet connection.

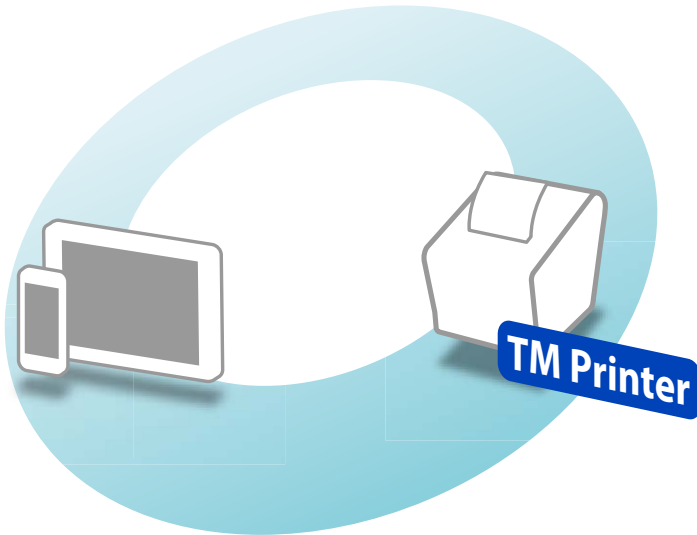

Customer Display Models

This is a system in which the TM printer and customer display are controlled from a smart device.

The customer display is connected to the TM printer, and the smart device and TM printer are connected through communication.

A connection method (*Bluetooth/Wi-Fi/Ethernet/USB*) conforming to the specifications of your smart device and TM printer can be selected.

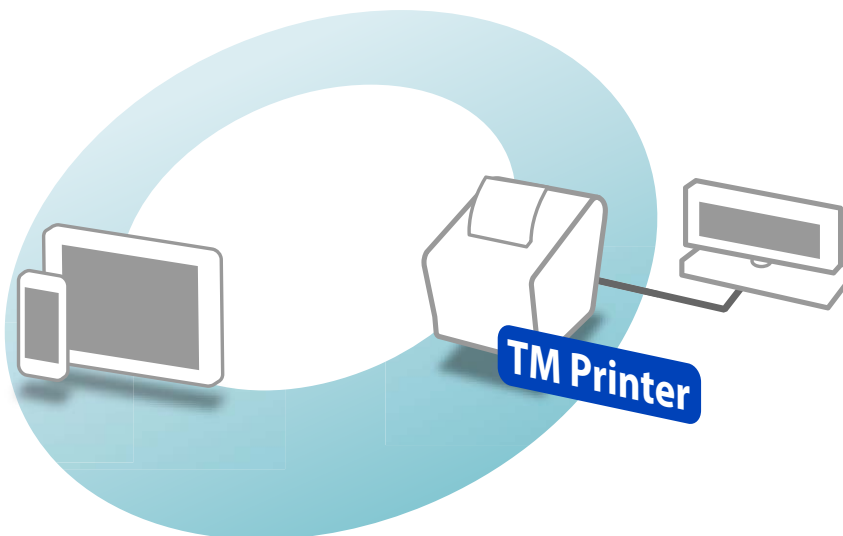

TM Printer + DM-D30 + barcode scanner model

This is a system in which the TM Printer and DM-D30, as well as the barcode scanner are controlled from a smart device.

The DM-D30 and the barcode scanner are connected to the TM Printer, and the smart device and TM Printer are connected through communication.

A connection method (*Bluetooth/Wi-Fi/Ethernet/USB*) conforming to the specifications of your smart device and the TM Printer can be selected.

TM Printer + DM-D30 + barcode scanner model can be configured by the following TM printer.

- TM-m30
- TM-m30II
- TM-m30II-H
- TM-T88VI

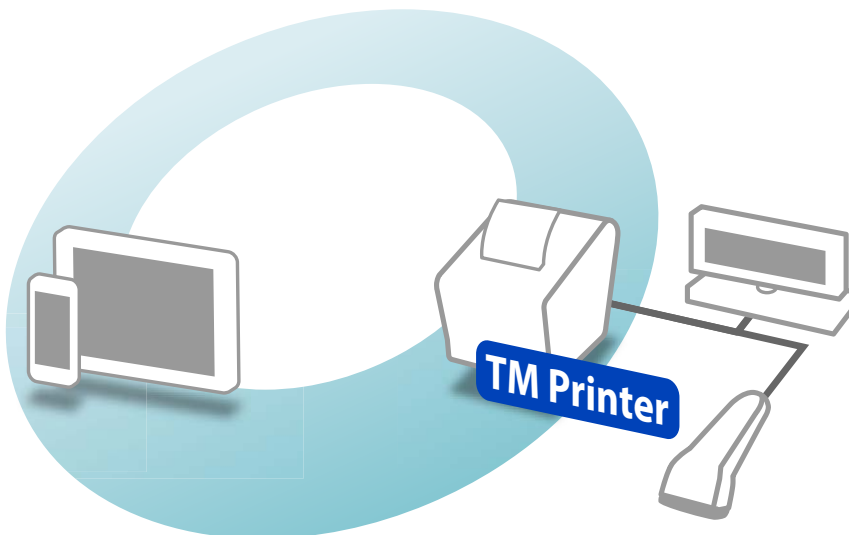

- The ePOS-Device settings of the TM printer must be set to "Enable."
 - * The ePOS-Device settings are made from EpsonNet Config (Web version) of the TM-m30.
 - * The default settings for the ePOS-Device settings of the TM-m30II/TM-m30II-H vary according to the destination.
Check the settings in EpsonNet Config (Web version) or TM-m30II Utility.
 - * The TM-T88VI ePOS-Device settings are carried out in TM-T88VI Utility.
- A combination of TM Printer + barcode scanner can also be used.

POS Terminal Model

This is a system in which a smart device and the TM printer (master) that acts as the POS terminal are connected through Wi-Fi/Ethernet network communication, and operation is performed by connecting multiple peripheral devices such as slave printers and customer display, etc. to the master printer.

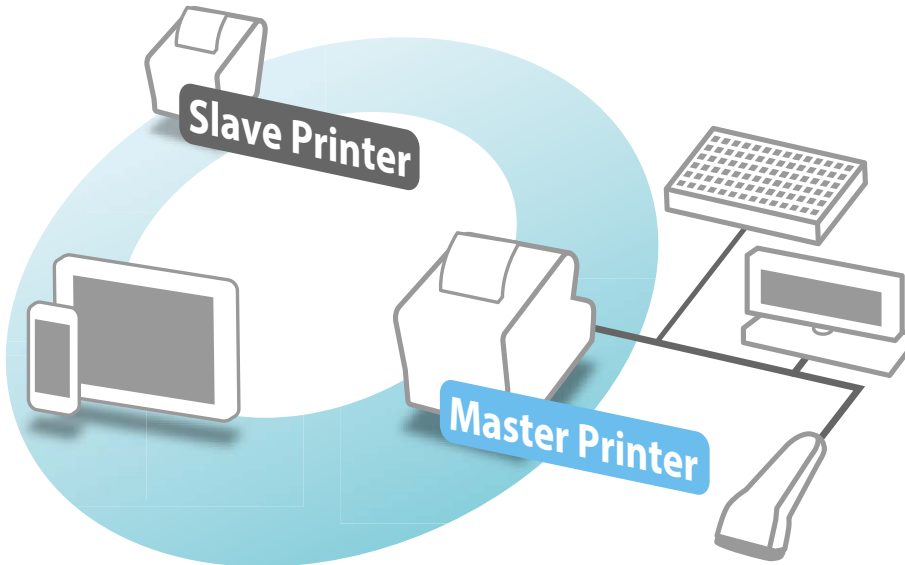

In addition to Epson's peripheral devices, the POS terminal model can control various peripheral devices from the device control program and device control script originally developed by Epson.

Since the software to be loaded and the version of the software differ depending on the TM printer that acts as the POS terminal, the peripheral devices that can be controlled are also different.

For details on controllable peripheral devices, refer to the Technical Reference Guide of the printer.

The device control programs are implemented in TM-DT series (TM-DT software version 4.0 or later).

Refer to TM-DT Series Peripheral Device Control Guide for information on the device control programs and device control scripts.

Epson ePOS SDK for Android Development Environment

The following development environment needs to be prepared to develop applications using the Epson ePOS SDK for Android.

- Android SDK r15 or later
- Java Development Kit 7 or later

Application Operating Environment

This section describes the operating environment for applications developed using the Epson ePOS SDK for Android.

For the most recent information on applicable smart devices, refer to the README.en.txt file contained in the "Epson ePOS SDK for Android" package.

Supported printers

The following list of printers can be controlled from the applications.



Usable interfaces vary depending on the specific TM printer. Refer to the Technical Reference Guide of each printer for more information.

Single-function models

- | | | |
|--------------------------------------|--------------------------------------|------------------------------------|
| <input type="checkbox"/> TM-m10 | <input type="checkbox"/> TM-T60 | <input type="checkbox"/> TM-T82X |
| <input type="checkbox"/> TM-m30 | <input type="checkbox"/> TM-T70 | <input type="checkbox"/> TM-T83II |
| <input type="checkbox"/> TM-m30II | <input type="checkbox"/> TM-T70II | <input type="checkbox"/> TM-T83III |
| <input type="checkbox"/> TM-m30II-H | <input type="checkbox"/> TM-T81II | <input type="checkbox"/> TM-T88V |
| <input type="checkbox"/> TM-T20 | <input type="checkbox"/> TM-T81III | <input type="checkbox"/> TM-T88VI |
| <input type="checkbox"/> TM-T20II | <input type="checkbox"/> TM-T82 | <input type="checkbox"/> TM-T100 |
| <input type="checkbox"/> TM-T20III | <input type="checkbox"/> TM-T82II | <input type="checkbox"/> TM-U220 |
| <input type="checkbox"/> TM-T20III L | <input type="checkbox"/> TM-T82III | <input type="checkbox"/> TM-U330 |
| <input type="checkbox"/> TM-T20X | <input type="checkbox"/> TM-T82III L | |

Mobile models

- | | |
|---------------------------------|-----------------------------------|
| <input type="checkbox"/> TM-P20 | <input type="checkbox"/> TM-P60II |
| <input type="checkbox"/> TM-P60 | <input type="checkbox"/> TM-P80 |

Hybrid models

- TM-H6000V

TM-i Series

- TM-T20II-i
- TM-T70-i (TM-i firmware Ver. 4.0 or later)
- TM-T82II-i
- TM-T83II-i
- TM-T88V-i (TM-i firmware Ver. 4.0 or later)
- TM-T88VI-iHUB
- TM-U220-i

TM-DT Series

- TM-T70II-DT
- TM-T70II-DT2
- TM-T88V-DT
- TM-T88VI-DT2
- TM-H6000IV-DT

Functions provided in each printer

Among the functions provided by Epson ePOS SDK for Android, those that can be used differ according to the printer.

Refer to the list below.

	SSL/TLS communication ^{*1}	Ring control of built-in buzzer	Ring control of optional external buzzer	Printing by multiple interfaces	Control of slave printers	Spooler/Print Forwarding	Communication Box	Control of peripheral devices ^{*2}	Simple selection using NFC tag	Simple selection using QR code
TM-m10	-	-	✓	✓	-	-	-	-	✓	✓
TM-m30	-	-	✓	✓ ^{*5}	-	-	-	✓	✓	✓
TM-m30II	-	-	✓	✓ ^{*5}	-	-	-	✓	✓	✓
TM-m30II-H	-	-	✓	✓ ^{*5}	-	-	-	✓	✓	✓
TM-T20	-	-	✓	-	-	-	-	-	-	✓
TM-T20II	-	-	✓	-	-	-	-	-	-	✓
TM-T20III	-	-	✓	-	-	-	-	-	-	✓
TM-T20IIIL	-	-	✓	-	-	-	-	-	-	✓
TM-T20X	-	-	✓	-	-	-	-	-	-	✓
TM-T60	-	-	-	-	-	-	-	-	-	✓
TM-T70	-	-	✓	-	-	-	-	-	-	✓
TM-T70II	-	✓ ^{*4}	✓	-	-	-	-	-	-	✓
TM-T81II	-	-	-	-	-	-	-	-	-	✓
TM-T81III	-	-	✓	-	-	-	-	-	-	✓
TM-T82	-	-	✓	-	-	-	-	-	-	✓
TM-T82II	-	✓ ^{*4}	✓	-	-	-	-	-	-	✓
TM-T82III	-	✓ ^{*4}	✓	-	-	-	-	-	-	✓
TM-T82IIIL	-	-	✓	-	-	-	-	-	-	✓
TM-T82X	-	-	✓	-	-	-	-	-	-	✓
TM-T83II	-	✓ ^{*4}	✓	-	-	-	-	-	-	✓
TM-T83III	-	-	✓	-	-	-	-	-	-	✓

	SSL/TLS communication *1	Ringling control of built-in buzzer	Ringling control of optional external buzzer	Printing by multiple interfaces	Control of slave printers	Spooler/Print Forwarding	Communication Box	Control of peripheral devices *2	Simple selection using NFC tag	Simple selection using QR code
TM-T88V	-	✓*4	✓	-	-	-	-	-	-	✓
TM-T88VI	✓*3	✓*4	✓	✓*5	-	-	-	✓	✓	✓
TM-T100	-	-	✓	-	-	-	-	-	-	✓
TM-U220	-	-	-	-	-	-	-	-	-	✓
TM-U330	-	-	-	-	-	-	-	-	-	✓
TM-P20	-	✓	-	-	-	-	-	-	✓	✓
TM-P60	-	-	-	-	-	-	-	-	-	✓
TM-P60II	-	✓	-	-	-	-	-	-	✓	✓
TM-P80	-	✓	-	-	-	-	-	-	✓	✓
TM-H6000V	✓	-	-	✓	-	-	-	✓	✓	✓
TM-T20II-i	✓	-	✓	-	✓	✓	✓	✓	-	-
TM-T70-i	✓	-	-	-	✓	✓	✓	✓	-	-
TM-T82II-i	✓	✓*4	✓	-	✓	✓	✓	✓	-	-
TM-T83II-i	✓	✓*4	✓	-	✓	✓	✓	✓	-	-
TM-T88V-i	✓	-	✓	-	✓	✓	✓	✓	-	-
TM-T88VI-iHUB	✓	✓*4	✓	-	✓	✓	✓	✓	✓	-
TM-U220-i	✓	-	-	-	✓	✓	✓	✓	-	-
TM-T70II-DT	✓	-	✓	-	✓	✓	✓	✓	-	-
TM-T70II-DT2	✓	-	✓	-	✓	✓	✓	✓	-	-
TM-T88V-DT	✓	-	✓	-	✓	✓	✓	✓	-	-
TM-T88VI-DT2	✓	-	✓	-	✓	✓	✓	✓	-	-
TM-H6000IV-DT	✓	-	-	-	✓	✓	✓	✓	-	-

*1: To communicate with the printer using SSL/TLS, select "TCPS" as the connection type in the connect API.

*2: The peripheral devices that can be used differ according to the printer. Refer to the Technical Reference Guide of each printer.

*3: Cannot be used in the system configuration of the customer display + barcode scanner model.

*4: Supports ringing control by the drawer kick command.

*5: Cannot be used in a system configuration with TM printer + barcode scanner.

Controllable Peripheral Devices

Control of the following peripheral devices is supported in Epson ePOS SDK for Android.



- The peripheral devices that can be used differ according to the printer. Refer to [Functions provided in each printer](#) or the Technical Reference Guide of each printer.
- By developing a device control program, a TM-DT series printer can control peripheral devices other than those introduced here.
Refer to TM-DT Series Peripheral Device Control Guide for information on the development.

Slave printer

Wi-Fi enabled models of the following TM printers

- TM-P20
- TM-P60II (Peeler)
- TM-P80

The following TM printers that are equipped with a Wi-Fi/Ethernet interface

- | | |
|-----------------------------------|-------------------------------------|
| <input type="checkbox"/> TM-T20 | <input type="checkbox"/> TM-T88V |
| <input type="checkbox"/> TM-T20II | <input type="checkbox"/> TM-T88VI |
| <input type="checkbox"/> TM-T70 | <input type="checkbox"/> TM-T90 |
| <input type="checkbox"/> TM-T70II | <input type="checkbox"/> TM-L90 |
| <input type="checkbox"/> TM-T82II | <input type="checkbox"/> TM-U220 |
| <input type="checkbox"/> TM-T83II | <input type="checkbox"/> TM-H6000IV |
| <input type="checkbox"/> TM-T88IV | |

The following TM-i Series/TM-DT Series

- | | |
|--|--|
| <input type="checkbox"/> TM-T20II-i | <input type="checkbox"/> TM-T88V-i (TM-i firmware Ver. 4.0 or later) |
| <input type="checkbox"/> TM-T70-i (TM-i firmware Ver. 4.0 or later) | <input type="checkbox"/> TM-T88V-DT (TM-DT software Ver.4.0 or later) |
| <input type="checkbox"/> TM-T70II-DT (TM-DT software Ver.4.0 or later) | <input type="checkbox"/> TM-U220-i |
| <input type="checkbox"/> TM-T82II-i | <input type="checkbox"/> TM-H6000IV-DT (TM-DT software Ver.4.0 or later) |
| <input type="checkbox"/> TM-T83II-i | |

Customer display

- | | |
|----------------------------------|----------------------------------|
| <input type="checkbox"/> DM-D30 | <input type="checkbox"/> DM-D110 |
| <input type="checkbox"/> DM-D210 | |

Peripheral Devices that can be Controlled by Device Control Programs

Peripheral devices conforming to the OPOS specifications can be controlled using the device control programs that are supported by TM-DT series (TM-DT software version 4.0 or later).

In the categories described below, peripheral devices having a driver that runs in combination with OPOS Common Control Object (OPOS CCO) 1.14.001 can be controlled.

- MSR
- POS keyboard
- Barcode scanner

Peripheral Devices that can be Controlled by Device Control Scripts

The peripheral devices listed below can be controlled from the device control scripts of the TM-i series/TM-DT series.

- Key input device
 - MSR (Hitachi-Omron Terminal Solutions, Corp.)
 - Keyboard (Standard HID device)
 - Barcode scanner (Standard HID device)
- Serial communication device

Downloadable Content

Epson ePOS SDK for Android packages include the following files.

Filename/Folder name	Description
ePOS2.jar	Java archive that contains Java class files compiled to use the APIs in Java program.
ePOSEasySelect.jar	Contains Java class files that enable simple printer selection.
libepos2.so	Libraries used for execution of functions (Compatible with ARMv5TE).
libeposeasyselect.so	Libraries used for functions that enable easy printer selection (Compatible with ARMv5TE).
armeabi	This is the folder to store libraries for ARMv5TE. The following files are stored: <ul style="list-style-type: none"> • libepos2.so • libeposeasyselect.so
arm64-v8a	This is the folder to store libraries for AArch64. The following files are stored: <ul style="list-style-type: none"> • libepos2.so • libeposeasyselect.so
x86_64	This is the folder to store libraries for x86-64.* The following files are stored: <ul style="list-style-type: none"> • libepos2.so • libeposeasyselect.so
OPOS_CCOs_1.14.001.msi	This is the OPOS CCO installer package.
ePOS2_Sample_Android.zip	These files are sample programs.
DeviceControlProgram_Sample.zip	This file contains sample device control programs.
README.jp.txt	This is the Japanese README file.
README.en.txt	This is the English README file.
EULA.jp.txt	This is the Japanese software license agreement.
EULA.en.txt	This is the English software license agreement.
ePOS_SDK_Android_um_ja_revx.pdf	This is the Japanese user manual.
ePOS_SDK_Android_um_en_revx.pdf	This is the English user manual.
TM-DT_Peripherals_ja_revx.pdf	This is the Japanese TM-DT Series Peripheral Device Control Guide. This guide describes how to control peripheral devices with TM-DT series.
TM-DT_Peripherals_en_revx.pdf	This is the English TM-DT Series Peripheral Device Control Guide.
JSON_Specification.pdf	This is the JSON specifications. This describes the JSON specifications that are used for GermanyFiscalElement class.
ePOS_SDK_Android_Migration_Guide_ja_revx.pdf	This is the Japanese migration guide. This guide describes the procedure to migrate from the ePOS-Print SDK or ePOS-Device SDK.

Filename/Folder name	Description
ePOS_SDK_Android_Migration_Guide_en_revx.pdf	This is the English migration guide.

* Operation is confirmed on virtual devices with architecture x86_64 and Android API 28 (Google APIs).

Web Content

Online reference is publicly available from the following website.

<https://reference.epson-biz.com/pos/reference/>

Limitations

- Set the barcode reader suffix (delimiter) to CR (carriage return code). Data cannot be obtained using any other settings.
- When using 2D barcode readers, Japanese and other multi-byte characters cannot be read correctly. However, when combining a TM-m30/TM-m30II/TM-m30II-H/TM-T88VI and 2D barcode reader to read a QR code, multi-byte characters encoded with UTF-8 can be obtained correctly.
- Control codes cannot be read from 2D barcode data if it contains ASCII control codes (0x00 through 0x1F).
- The number of device ports that can be simultaneously opened in the same application is 16 ports.
- Activity may sometimes be destroyed when rotating the screen. When storing print instances as Activity, call `closePrinter` from the `Print` class before the Activity is destroyed.
- Communication will be disrupted if a terminal enters sleep mode while communicating with a printer via a *Bluetooth* connection.
- When using a virtual device, a MAC address cannot be used in the target parameter for the connect API.

How to Use

This section describes how to create Epson ePOS SDK for Android projects and some basic programming methods used in the Epson ePOS SDK for Android.

Printer Connections

Connect smart devices and printers using a connection method that matches the system you want to create. Refer to the Technical Reference Guide of each printer for more information.



To connect via USB, refer to [To connect via USB](#).

Creating an Epson ePOS SDK for Android Project



You can get the Android Studio from the following URL.
<http://developer.android.com/sdk/index.html>

- 1 Start Android Studio and click on **Start a new Android Studio project** to create a new project.

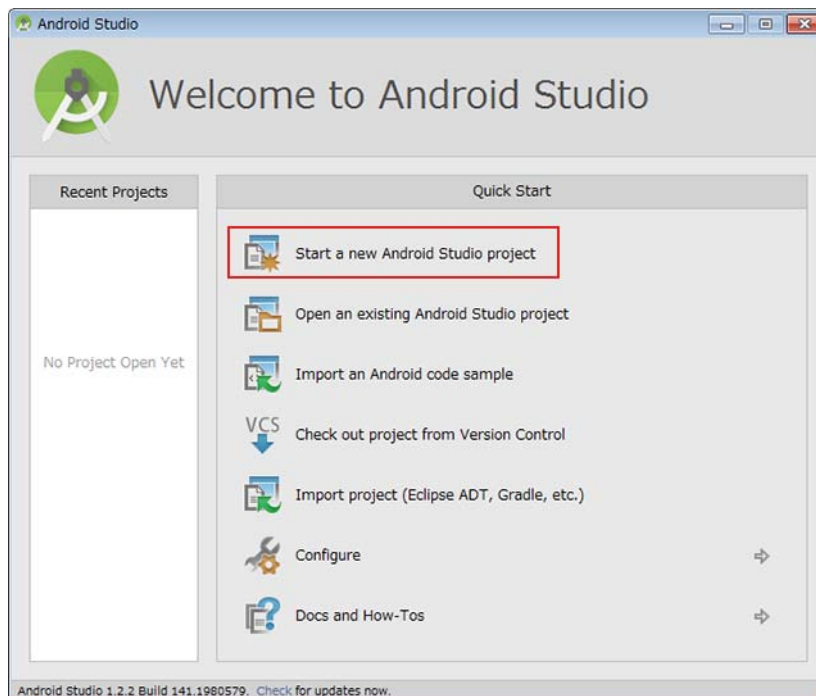

- 2** Configure the project in accordance with the type of application you will create. Configure the project in accordance with the instructions shown on the screen.

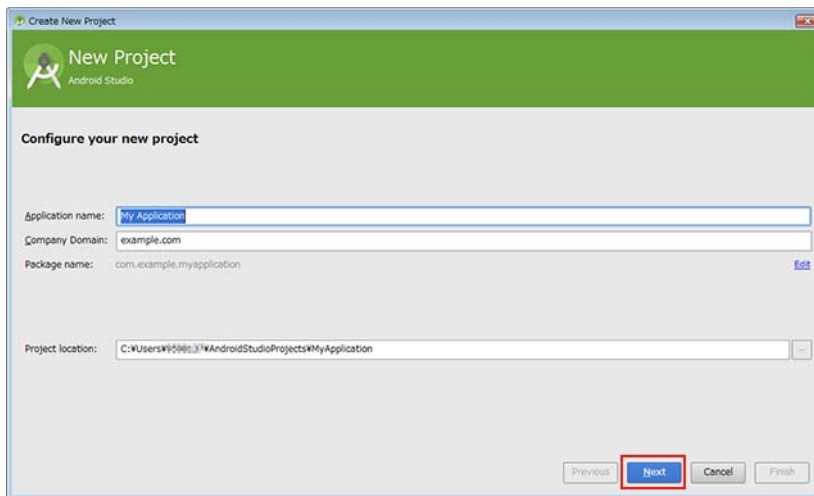

- 3** Store ePOS2.jar and ePOSEasySelect.jar in the following location.
C:\Users\[account name]\AndroidStudioProjects\[project name]\app\libs



The folder structure after [project name] is automatically created when the project is created.

- 4** Create the following folder structure.
C:\Users\[account name]\AndroidStudioProjects\[project name]\app\src\main\jniLibs
- 5** Depending on your CPU, store the following folders bundled with this package in the jniLibs folder:
- armeabi
 - arm64-v8a
 - x86_64

6 Open the project that was created in Android Studio.

7 Run **Clean Project** from the **Build** menu.

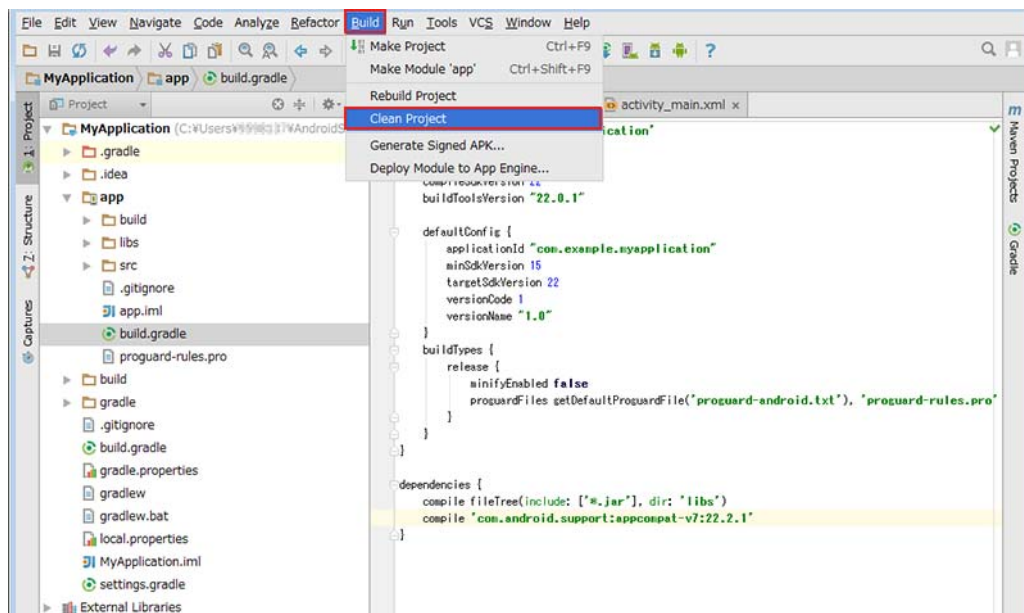

8 Double-click on **AndroidManifest.xml**.

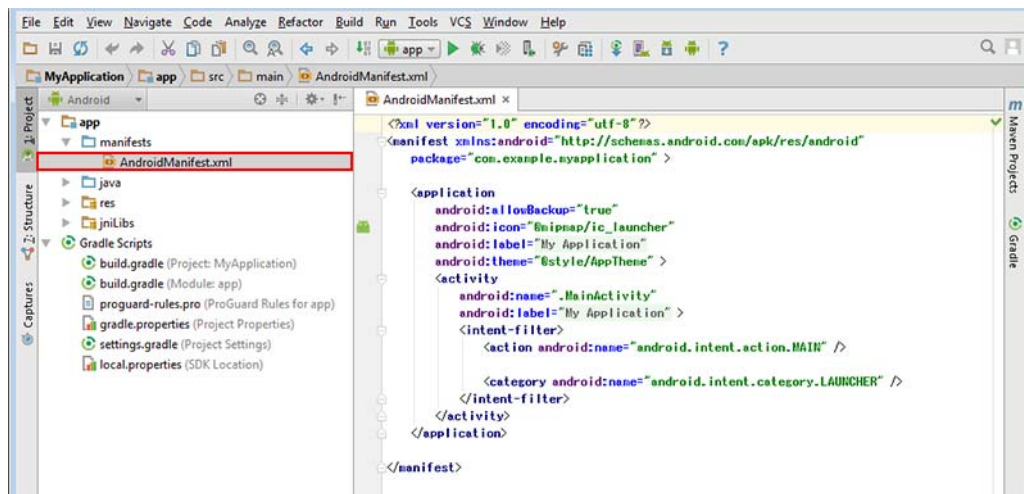

9 Under the <manifest> element, declare the permission that specifies the method for connecting with devices.



It is recommended to declare the permission even when connecting with a device via USB.
Refer to README.en.txt for more information.

❑ Wi-Fi

```
<uses-permission android:name="android.permission.INTERNET"/>
```

❑ Bluetooth

"ACCESS_COARSE_LOCATION" is required for Android 6.0 or later.

```
<uses-permission android:name="android.permission.BLUETOOTH"/>
<uses-permission android:name="android.permission.BLUETOOTH_ADMIN"/>
<uses-permission
  android:name="android.permission.ACCESS_COARSE_LOCATION"/>
```

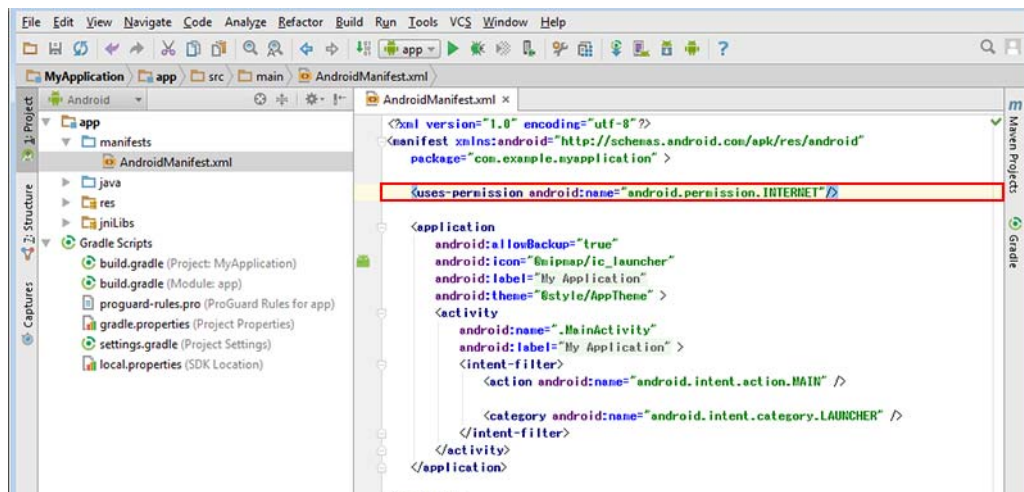

Programming Guide

This section describes some of the basic programming methods used in the Epson ePOS SDK for Android.

Programming Flow

This section describes a flow to create a program for controlling printers or peripheral devices respectively.

- [Controlling Printers](#)
- [Controlling Customer Displays](#)
- [Controlling Keyboards and Barcode Scanners](#)



Do not add an API of Epson ePOS SDK in the callback.

Controlling Printers

The method of controlling the TM printer and slave printer, and programming receipt printing is described below.

1. Printer selection (class initialization)



2. Creating print data (data buffering)



3. Sending print data (connection with the devices/communication/printing/disconnection)

Printer selection (class initialization)

Initialize the Printer class and select the printer to control.

```
Printer printer = null;
try {
    printer = new Printer(Printer.TM_T88, Printer.MODEL_ANK, this);
}
catch (Epos2Exception e) {
    //Displays error messages
}
```

Register the print complete event listener.

```
printer.setReceiveEventListener(this);
```

Creating print data (data buffering)

Use add* API commands in the Printer class to create print data.

In the following example, data is created to print "Hello World" aligned in the center.

```
try {
    printer.addTextAlign(Printer.ALIGN_CENTER);
    printer.addText("Hello World");
}
catch (Epos2Exception e) {
    //Displays error messages
}
```

Sending print data (connection with the devices/communication/printing/disconnection)

Connect to the printer to which the created print data will be sent.

```
try {
    printer.connect("TCP:192.168.192.168", Printer.PARAM_DEFAULT);
}
catch (Epos2Exception e) {
    //Displays error messages
}
```

Run the print process and retrieve the print result in the callback. Do not add an API command in the callback.

```
try {
    printer.sendData(Printer.PARAM_DEFAULT);
}
catch (Epos2Exception e) {
    // Displays error messages
    // Abort process
}

public void onPtrReceive(final Printer printerObj, final int code, final PrinterStatusInfo status,
final String printJobId) {
    runOnUiThread(new Runnable() {
        @Override
        public synchronized void run() {
            if (code == Epos2CallbackCode.CODE_SUCCESS) {
                //Displays successful print messages
            }
            else {
                //Displays error messages
            }
        }
    });
    new Thread(new Runnable() {
        @Override
        public synchronized void run() {
            //Abort process
        }
    }).start();
}
```



When an error occurs, the print data that has been created is not erased until the command buffer is cleared. The print data can be used for re-printing in cases such as when the error processing ends.

Disconnect from the printer.

```
try {
    printer.disconnect();
}
catch (Epos2Exception e) {
    //Displays error messages
}
```

Clear the command buffer and terminate the printer control.

```
printer.clearCommandBuffer();
printer.setReceiveEventListener(null);
```

Controlling Customer Displays

This section describes the programming methods for controlling customer displays and displaying text on displays.

1. Device selection (class initialization)



2. Creating display data (data buffering)



3. Sending display data (connection with the devices/communication/printing/disconnection)

Device selection (class initialization)

Initialize the LineDisplay class and connect to the customer display.

```
LineDisplay linedisplay = null;
try {
    linedisplay = new LineDisplay(LineDisplay.DM_D30, this);
}
catch (Epos2Exception e) {
    //Displays error messages
}
```

Register the view complete event listener.

```
linedisplay.setReceiveEventListener(this);
```

Creating display data (data buffering)

Use add* API commands in the LineDisplay class to create display data.

In the following example, data is created to display "Hello World".

```
try {
    linedisplay.addText("Hello World");
}
catch (Epos2Exception e) {
    //Displays error messages
}
```

Sending display data (connection with the devices/communication/printing/disconnection)

Connect the customer display to which created display data will be sent.

```
try {
    linedisplay.connect("TCP:192.168.192.168", LineDisplay.PARAM_DEFAULT);
}
catch (Epos2Exception e) {
    //Displays error messages
}
```

Run the display process and retrieve the display result.

```
if (status.connection) {
    try {
        linedisplay.sendData();
    } catch (Epos2Exception e) {
        // Displays error messages
        // Abort process
    }
} else {
    // Displays error messages
    // Abort process
}

public void onDispReceive(final LineDisplay displayObj, final int code){
    runOnUiThread(new Runnable() {
        @Override
        public synchronized void run() {
            if (code == Epos2CallbackCode.CODE_SUCCESS) {
                //Displays successful print messages
            }
            else {
                //Displays error messages
            }
        }
    });
    new Thread(new Runnable() {
        @Override
        public synchronized void run() {
            //Abort process
        }
    }).start();
}
```

Disconnect from the customer display.

```
try {
    linedisplay.disconnect();
}
catch (Epos2Exception e) {
    //Displays error messages
}
```

Clear the command buffer and terminate the customer display control.

```
linedisplay.clearCommandBuffer();
linedisplay.setReceiveEventListener(null);
```

Controlling Keyboards and Barcode Scanners

This section describes how to create a program that enables receiving data input from keyboards and barcode scanners.

The following section describes the programming flow for controlling keyboards.

1. Connecting to the device



2. Receiving data



3. Disconnecting from the device

Connecting to the device

Initialize the Keyboard class, connect the keyboard, and then register the event listener that will receive input data.

```
Keyboard keyboard = null;
try {
    keyboard = new Keyboard(this);
    keyboard.setKeyPressEventListener(mKeyPressEvent);
    keyboard.connect("TCP:192.168.192.168[local_keyboard]", Keyboard.PARAM_DEFAULT);
}
catch (Epos2Exception e) {
    //Displays errors
    keyboard.setKeyPressEventListener(null);
}
```

Receiving data

Create the key press event listener.

```
private KeyPressListener mKeyPressEvent = new KeyPressListener() {
    @Override
    public void onKbdKeyPress(Keyboard keyboardObj, final int keyCode, final String ascii) {
        runOnUiThread(new Runnable() {
            @Override
            public synchronized void run() {
                if (keyCode != 0) {
                    //Displays receive messages.
                }
            }
        });
    }
};
```

Disconnecting from the device

Disrupt communication to terminate the reception of input data from the keyboard.

```
try {
    keyboard.disconnect();
}
catch (Epos2Exception e) {
    //Displays errors
}

keyboard.setKeyPressEventListener(null);

keyboard = null;
```

Effective range of command buffers for setting

The valid range of add* of the Printer class used for setting depends on the print method.

Receipt

Effective after setting add* until `sendData` is executed.

The configured values are initialized every time `sendData` is executed. See below.

```
printer.addText("Hello World!\n");
printer.addTextFont(Printer.FONT_B);
printer.addText("Hello World!\n");
printer.addText("Hello World!\n");
printer.sendData(Printer.PARAM_DEFAULT);
printer.clearCommandBuffer;
printer.addText("Hello World!\n");
printer.sendData(Printer.PARAM_DEFAULT);
printer.clearCommandBuffer;
```

Red letters: Font A

Green letters: Font B

Slip, Endorsement, Validation

Effective after setting add* until the paper is ejected.

The configured values are initialized each time the following APIs are executed:

- `waitInsertion`
- `readMicrData`
- `sendData` (receipt printing)

See below.

```
HybridPrinter.selectPaperType(HybridPrinter.PAPER_TYPE_SLIP);
HybridPrinter.waitInsertion(HybridPrinter.PARAM_DEFAULT);
HybridPrinter.addText("Hello World!\n");
HybridPrinter.addTextFont(Printer.FONT_B);
HybridPrinter.addText("Hello World!\n");
HybridPrinter.addText("Hello World!\n");
HybridPrinter.sendData(Printer.PARAM_DEFAULT);
HybridPrinter.clearCommandBuffer;
HybridPrinter.addText("Hello World!\n");
HybridPrinter.sendData(Printer.PARAM_DEFAULT);
HybridPrinter.clearCommandBuffer;
HybridPrinter.ejectPaper;
HybridPrinter.selectPaperType(HybridPrinter.PAPER_TYPE_RECEIPT);
HybridPrinter.addText("Hello World!\n");
HybridPrinter.sendData(Printer.PARAM_DEFAULT);
```

Red letters: Font A

Green letters: Font B

Status

The following statuses are defined in the Epson ePOS SDK for Android.

❑ Error status

Indicates a result of sending data to devices in each class. The result is sent immediately as an exception of API. Refer to [Error Status and countermeasures](#) for more information.

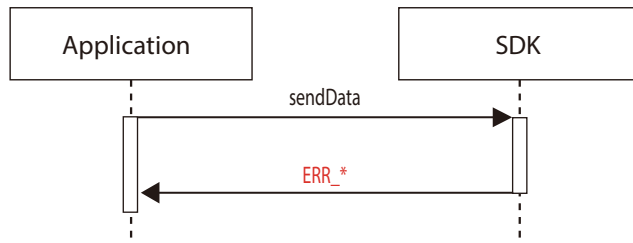

❑ Callback code

Indicates a device's processing result for [sendData](#). Notified in a print completion event ([onPtrReceive/onDis-pReceive](#)). Refer to [Callback Code and countermeasures](#) for more information.

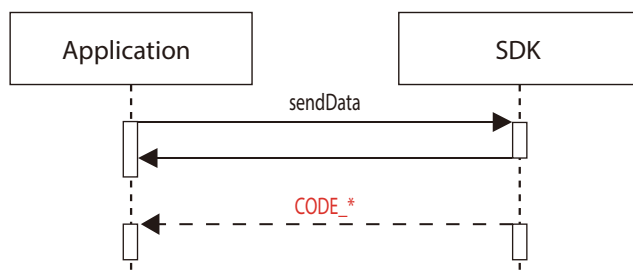

❑ Printer status

Indicates the status of printers when sending print data. The printer status is retrieved when executing [send-Data](#). Refer to [Printer Status and countermeasures](#) for more information.

Handling Exceptions

When an errors occurs while using the Epson ePOS SDK for Android, a unique exception with a numerical (int) parameter is generated and the call originator is notified of the error. The notified error is retrieved by [getErrorStatus](#) in the `Epos2Exception` class.

Refer to the following programming code.

```

Printer printer = null;
printer = new Printer(Printer.TM_T88, Printer.MODEL_ANK, this);
try {
    printer.connect("TCP:192.168.192.168", Print.PARAM_DEFAULT);
    printer.disconnect();
}
catch (Epos2Exception e) {
    //Retrieves the error status
    int ErrorStatus = ((Epos2Exception) e).getErrorStatus();
}
  
```

API Reference

This chapter describes the APIs provided by Epson ePOS SDK for Android.

List of ePOS SDK API

Epson ePOS SDK for Android provides the following classes:

	<ul style="list-style-type: none"> Available APIs and parameters vary by printer model and peripheral device. Refer to List of Supported Classes. For the list of APIs of each class, and the APIs supported by each printer, refer to List of Supported APIs.
---	--

- [Printer class](#)
- [HybridPrinter class](#)
- [LineDisplay class](#)
- [Keyboard class](#)
- [POSKeyboard class](#)
- [BarcodeScanner class](#)
- [MSR class](#)
- [SimpleSerial class](#)
- [GermanyFiscalElement class](#)
- [OtherPeripheral class](#)
- [CommBox class](#)
- [Common to all classes](#)
- [Discovery class](#)
- [Epos2Exception class](#)
- [Log class](#)
- [EasySelect class](#)
- [EasySelectInfo class](#)

Printer class

Controls printing by the printer.

API		Description
Initialization	Printer	Initializes the Printer class.
Communication path	connect	Connects to the printer.
	disconnect	Disconnects from the printer.
Status monitor	startMonitor	Enables status event notification.
	stopMonitor	Disables status event notification.

	API	Description
Status acquisition	getStatus	Acquires status of the connected printer.
Transmission	sendData	Sends a command to the printer.
Transaction	beginTransaction	Starts a transaction.
	endTransaction	Ends a transaction.
Print job	requestPrintJobStatus	Acquires the print result.
Buffer clear	clearCommandBuffer	Clears the command buffer.
Text	addTextAlign	Adds text alignment setting to the command buffer.
	addLineSpace	Adds line spacing setting to the command buffer.
	addTextRotate	Adds text rotation setting to the command buffer.
	addText	Adds text to print to the command buffer.
	addTextLang	Adds language setting to the command buffer.
	addTextFont	Adds character font setting to the command buffer.
	addTextSmooth	Adds character smoothing setting to the command buffer.
	addTextSize	Adds character scaling factor setting to the command buffer.
	addTextStyle	Adds character style setting to the command buffer.
Paper feed	addHPosition	Adds character print position setting to the command buffer.
	addFeedUnit	Adds paper-feed setting in dots to the command buffer.
Graphics	addFeedLine	Adds paper-feed setting in lines to the command buffer.
	addImage	Adds a raster image print command to the command buffer.
Barcode	addLogo	Adds a NV logo print command to the command buffer.
	addBarcode	Adds a barcode print command to the command buffer.
	addSymbol	Adds a 2D symbol print command to the command buffer.

API		Description
Ruled line	addHLine	Adds a horizontal ruled line print command to the command buffer.
	addVLineBegin	Adds a vertical ruled line start command to the command buffer.
	addVLineEnd	Adds a vertical ruled line end command to the command buffer.
Page mode	addPageBegin	Adds a page mode start command to the command buffer.
	addPageEnd	Adds a page mode end command to the command buffer.
	addPageArea	Adds page mode print area setting to the command buffer.
	addPageDirection	Adds page mode print direction setting to the command buffer.
	addPagePosition	Adds page mode print position setting to the command buffer.
	addPageLine	Adds a page mode line draw command to the command buffer.
	addPageRectangle	Adds a page mode rectangle draw command to the command buffer.
Batch rotate print	addRotateBegin	Adds the start batch rotate print mode to the command buffer.
	addRotateEnd	Adds the end batch rotate print mode to the command buffer.
Cut	addCut	Adds a sheet cut command to the command buffer.
Drawer	addPulse	Adds a drawer kick command to the command buffer.
Buzzer	addSound	Adds a buzzer sound command to the command buffer.
Label sheet/ black mark sheet	addFeedPosition	Adds a paper feed command to the command buffer.
	addLayout	Adds sheet layout setting to the command buffer.
Command	addCommand	Adds a command to the command buffer.
Maintenance counter	getMaintenanceCounter	Acquires the counter value.
	resetMaintenanceCounter	Resets the counter value.
Printer setting	getPrinterSetting	Acquires the set value of the printer setting.
	setPrinterSetting	Changes the printer setting.

API		Description
Firmware update	downloadFirmwareList	Acquires the list of the firmware.
	getPrinterFirmwareInfo	Acquires the information of the printer firmware.
	verifyUpdate	Acquires the result of the firmware update.
	updateFirmware	Instructs the printer to write the firmware image.
Forced transmission	forceRecover	Forced transmission function
	forcePulse	
	forceStopSound	
	forceCommand	
	forceReset	
Reception of result	setStatusChangeListener	Registers the event listener registration method.
	setReceiveEventListener	
Monitor interval	interval	<Obsolete> Status monitor interval

The print mode includes the standard mode, page mode, and the batch rotate print mode.

- Standard mode

Prints line by line. Line spacing is automatically adjusted according to character size, image size, and barcode height. Suitable for printing receipts whose print length varies by print content.

- Page mode

Prints page by page. Prints characters, images, and/or barcodes on a single page that is defined as a print area.

To print in the page mode, use [addPageBegin](#) and [addPageEnd](#) to start and end the page mode process, respectively.

- Batch rotate print mode

This is a print mode in which the range of the print data (such as characters, images, barcodes, etc.) is set, the print data in the set range is compiled, inverted, and then printed.

When performing the processing in the batch rotate print mode, start the batch rotate print processing with [addRotateBegin](#), and end the batch rotate print processing with [addRotateEnd](#).

The APIs that can be used in each mode are described in the table below.

API	Standard mode	Page mode	Batch rotate print mode
Printer	-	-	-
connect	-	-	-
disconnect	-	-	-
startMonitor	✓	✓	✓
stopMonitor	✓	✓	✓
getStatus	✓	✓	✓
sendData	✓	✓	-
beginTransaction	✓	✓	✓

API	Standard mode	Page mode	Batch rotate print mode
endTransaction	✓	✓	-
requestPrintJobStatus	✓	✓	✓
clearCommandBuffer	✓	✓	-
addTextAlign	✓	-	✓
addLineSpace	✓	✓	✓
addTextRotate	✓	-	✓
addText	✓	✓	✓
addTextLang	✓	✓	✓
addTextFont	✓	✓	✓
addTextSmooth	✓	✓	✓
addTextSize	✓	✓	✓
addTextStyle	✓	✓	✓
addHPosition	✓	✓	✓
addFeedUnit	✓	✓	✓
addFeedLine	✓	✓	✓
addImage	✓	✓	✓
addLogo	✓	✓	✓
addBarcode	✓	✓	✓
addSymbol	✓	✓	✓
addHLine	✓	-	✓
addVLineBegin	✓	-	✓
addVLineEnd	✓	-	✓
addPageBegin	✓	-	-
addPageEnd	-	✓	-
addPageArea	-	✓	-
addPageDirection	-	✓	-
addPagePosition	-	✓	-
addPageLine	-	✓	-
addPageRectangle	-	✓	-
addRotateBegin	✓	-	-
addRotateEnd	-	-	✓
addCut	✓	-	-
addPulse	✓	-	-
addSound	✓	-	-

API	Standard mode	Page mode	Batch rotate print mode
addFeedPosition	✓	-	✓
addLayout	✓	-	✓
addCommand	✓	✓	✓

HybridPrinter class

Controls the hybrid model printers.

API		Description
Initialization	HybridPrinter	Initializes the HybridPrinter class.
Communication path	connect	Connects to the printer.
	disconnect	Disconnects from the printer.
Status monitor	startMonitor	Enables status event notification.
	stopMonitor	Disables status event notification.
Status acquisition	getStatus	Acquires status of the connected printer.
Transmission	sendData	Transfers a print command.
Transaction	beginTransaction	Starts a transaction.
	endTransaction	Ends a transaction.
Buffer clear	clearCommandBuffer	Clears the command buffer.
Print method	selectPaperType	Specifies a print method.
Paper feed	waitInsertion	Waiting for paper insertion.
	cancelInsertion	Cancels waiting for paper insertion.
Paper eject	ejectPaper	Ejects paper.
MICR	readMicrData	MICR reading
	cleanMicrReader	Cleans the MICR mechanism.
Forced transmission	forceRecover	Forced transmission function
	forcePulse	
	forceCommand	
	forceReset	
Print method acquisition	paperType	Acquires the print method setting information.
Monitor interval	interval	Printer status update interval
On standby	waitTime	Time from insertion of a paper to start of operation
40cpl mode	mode40Cpl	Sets the 40 cpl mode.
Reception of result	setStatusChangeListener	Registers the event listener registration method.
	setReceiveEventListener	

List of supported control operations for HybridPrinter class

APIs available for the HybridPrinter class depend on the type of control operation.

The following lists control operation types and available APIs.

API	Control operation				
	Receipt	Slip sheet	Endorsement	Validation	MICR
HybridPrinter	✓	✓	✓	✓	✓
connect	✓	✓	✓	✓	✓
disconnect	✓	✓	✓	✓	✓
startMonitor	✓	✓	✓	✓	✓
stopMonitor	✓	✓	✓	✓	✓
getStatus	✓	✓	✓	✓	✓
sendData	✓	✓	✓	✓	-
beginTransaction	✓	✓	✓	✓	✓
endTransaction	✓	✓	✓	✓	✓
clearCommandBuffer	✓	✓	✓	✓	-
selectPaperType	✓	✓	✓	✓	-
waitInsertion	-	✓	✓	✓	-
cancelInsertion	-	✓	✓	✓	✓
ejectPaper	-	✓	✓	✓	✓
readMicrData	-	-	-	-	✓
cleanMicrReader	-	-	-	-	✓
setStatusChangeListener	✓	✓	✓	✓	✓
setReceiveEventListener	✓	✓	✓	✓	✓

Creating print document by the HybridPrinter class

The HybridPrinter class creates a print document using the same API as the [Printer class](#).

The APIs and corresponding print methods are listed below.

API		Print method				
		Receipt	Slip sheet	Endorsement	Endorsement (40cpl)	Validation
Text	addTextAlign	✓	✓	✓	-	✓
	addLineSpace	✓	✓	✓	-	✓
	addTextRotate	✓	✓	✓	✓	✓
	addText	✓	✓	✓	✓	✓
	addTextLang	✓	✓	-	-	✓
	addTextFont	✓	✓	✓	-	✓
	addTextSmooth	✓	-	-	-	-
	addTextSize	✓	✓	✓	-	✓
	addTextStyle	✓	✓*	✓*	-	✓*
	addHPosition	✓	✓	✓	✓	✓
Paper feed	addFeedUnit	✓	✓	✓	✓	✓
	addFeedLine	✓	✓	✓	✓	✓
Graphics	addImage	✓	-	-	-	-
	addLogo	✓	-	-	-	-
Barcode	addBarcode	✓	-	-	-	-
	addSymbol	✓	-	-	-	-
Page mode	addPageBegin	✓	✓	-	-	✓
	addPageEnd	✓	✓	-	-	✓
	addPageArea	✓	✓	-	-	✓
	addPageDirection	✓	✓	-	-	✓
	addPagePosition	✓	✓	-	-	✓
	addPageLine	✓	✓	-	-	-
	addPageRectangle	✓	✓	-	-	-
Cut	addCut	✓	-	-	-	-
Drawer	addPulse	✓	✓	✓	✓	✓
Command	addCommand	✓	✓	✓	✓	✓

*The reverse parameter is not supported.

LineDisplay class

Controls character display on the customer display.

API		Description	
Initialization	LineDisplay	Initializes the LineDisplay class.	
Communication path	connect	Connects to the customer display.	
	disconnect	Disconnects from the customer display.	
Status acquisition	getStatus	Acquires status of the connected device.	
Transmission	sendData	Sends a command to the customer display.	
Buffer clear	clearCommandBuffer	Clears the command buffer.	
Reset	addInitialize	Initializes the customer display.	
Window	addCreateWindow	Adds a process to execute to the command buffer.	
	addDestroyWindow		
	addSetCurrentWindow		
	addClearCurrentWindow		
Cursor	addSetCursorPosition		
	addMoveCursorPosition		
	addSetCursorType		
Text display	addText		
	addReverseText		
	addMarqueeText		
Display setting	addSetBlink		
	addSetBrightness		
Clock	addShowClock		
Command transfer	addCommand		
Reception of result	setReceiveEventListener		Registers the event listener registration method.

Keyboard class

Controls character entry from the keyboard.

API		Description
Initialization	Keyboard	Initializes the Keyboard class.
Communication path	connect	Connects to the keyboard.
	disconnect	Disconnects from the keyboard.
Status acquisition	getStatus	Acquires status of the connected device.

API		Description
String setting	setPrefix	Sets the condition to handle as a continuous string.
String setting acquisition	getPrefix	Acquires the set prefix.
Key detection	setKeyPressEventListener	Registers the event listener registration method.
String detection	setReadStringEventListener	

POSKeyboard class

Controls character entry from the POS keyboard.

API		Description
Initialization	PosKeyboard	Initializes the POSKeyboard class.
Communication path	connect	Connects to the keyboard.
	disconnect	Disconnects from the keyboard.
Status acquisition	getStatus	Acquires status of the connected device.
Key detection	setKeyPressEventListener	Registers the event listener registration method.

BarcodeScanner class

Controls barcode reading by the barcode scanner.

API		Description
Initialization	BarcodeScanner	Initializes the BarcodeScanner class.
Communication path	connect	Connects to the barcode scanner.
	disconnect	Disconnects from the barcode scanner.
Status acquisition	getStatus	Acquires status of the connected device.
Input data reception	setScanEventListener	Registers the event listener registration method.

MSR class

Controls card reading by the MSR.

API		Description
Initialization	Msr	Initializes the MSR class.
Communication path	connect	Connects to the MSR.
	disconnect	Disconnects from the MSR.
Status acquisition	getStatus	Acquires status of the connected device.
Data detection	setDataEventListener	Registers the event listener registration method.

SimpleSerial class

Controls serial communication between the printer and device.

	API	Description
Initialization	SimpleSerial	Initializes the SimpleSerial class.
Communication path	connect	Connects to the serial.
	disconnect	Disconnects from the serial.
Status acquisition	getStatus	Acquires status of the connected device.
Command transfer	sendCommand	Transfers a command.
Input data reception	setReceiveEventListener	Registers the event listener registration method.

GermanyFiscalElement class

Connects to the German fiscal element (TSE), and controls data read/write operations.

	API	Description
Initialization	GermanyFiscalElement	Initializes the GermanyFiscalElement class.
Communication path	connect	Connects to the German fiscal element (TSE).
	disconnect	Disconnects from the German fiscal element (TSE).
Status acquisition	getStatus	Acquires status of the German fiscal element (TSE).
Operation	operate	Send the JSONsring to the German fiscal element (TSE).
Reception of result	setReceiveEventListener	Registers the callback method for an event.

OtherPeripheral class

Controls peripheral devices via the developed device control programs.

	API	Description
Initialization	OtherPeripheral	Initializes the OtherPeripheral class.
Communication path	connect	Connects to the device.
	disconnect	Disconnects from the device.
Status acquisition	getStatus	Acquires status of the connected device.
Transmission	sendData	Sends data to the peripheral device.
Reception of result	setReceiveEventListener	Registers the event listener registration method.

CommBox class

Controls data transmission and reception using the communication box.

API		Description
Initialization	CommBox	Initialize the CommBox class.
Communication path	connect	Connects to the communication box.
	disconnect	Disconnects from the communication box.
Status acquisition	getStatus	Acquires status of the connected device.
Transmission history	getCommHistory	Acquires the message transmission history.
Transmission	sendMessage	Sends a message to the communication box.
Reception	setReceiveEventListener	Registers the event listener registration method.

Common to all classes

These APIs can be used with all classes.

API		Description
Administration information	getAdmin	Acquires the administration information.
	getLocation	Acquires the installation location information.
Reconnection	setConnectionEventListener	Registers the event listener registration method.

Discovery class

Controls the device discovery function.

API		Description
Start	start	Starts device search.
Stop	stop	Stops device search.

Epos2Exception class

Acquires the error status when an exception occurs.

API		Description
Error status acquisition	getErrorStatus	Acquires the error status when an exception is thrown.

Log class

Controls the log output function.

API		Description
Log	setLogSettings	Sets the log output function.
Version acquisition	SdkVersion	Acquires the Epson ePOS SDK version.

EasySelect class

EasySelect class and EasySelectInfo class offer API commands and member variables for selecting printers by using NFC tags or QR codes.

EasySelect class is for analyzing NFC tags and QR codes.

API		Description
Analyzing of NFC tags	parseNFC	Analyzes NFC tags data.
Analyzing of QR codes	parseQR	Analyzes QR codes data.
Creation of QR codes	createQR	Creates QR code data that can be analyzed by parseQR .

EasySelectInfo class

This class is for storing data analyzed by [parseNFC](#) or [parseQR](#). Specify the stored information in [connect](#) API to connect with the printer.

Member variables		Description
Printer type	deviceType	Stores printer type information.
Printer name	printerName	Stores a printer name.
MAC address/BD address	macAddress	Stores a MAC address or a BD address.

Printer class

Printer

Initializes the Printer class.

Syntax

```
public Printer(int printerSeries, int lang, Context context)
throws Epos2Exception
```

Parameter

printerSeries

Specifies the target printer.

Value	Description
Printer.TM_M10	TM-m10
Printer.TM_M30	TM-m30
Printer.TM_M30II	TM-m30II, TM-m30II-H
Printer.TM_P20	TM-P20
Printer.TM_P60	TM-P60 (Receipt/Peeler)
Printer.TM_P60II	TM-P60II (Receipt/Peeler)
Printer.TM_P80	TM-P80
Printer.TM_T20	TM-T20, TM-T20II, TM-T20II-i, TM-T20III, TM-T20IIIL, TM-T20X
Printer.TM_T60	TM-T60
Printer.TM_T70	TM-T70, TM-T70-i, TM-T70II, TM-T70II-DT, TM-T70II-DT2
Printer.TM_T81	TM-T81II, TM-T81III
Printer.TM_T82	TM-T82, TM-T82II, TM-T82II-i, TM-T82III, TM-T82IIIL, TM-T82X
Printer.TM_T83	TM-T83II, TM-T83II-i
Printer.TM_T83III	TM-T83III
Printer.TM_T88	TM-T88IV, TM-T88V, TM-T88VI, TM-T88V-i, TM-T88VI-iHUB, TM-T88V-DT, TM-T88VI-DT2
Printer.TM_T90	TM-T90
Printer.TM_T100	TM-T100
Printer.TM_U220	TM-U220, TM-U220-i

Value	Description
Printer.TM_U330	TM-U330
Printer.TM_L90	TM-L90
Printer.TM_H6000	TM-H6000IV, TM-H6000V, TM-H6000IV-DT

lang

Specifies the language of the printer.

Value	Description
Printer.MODEL_ANK	ANK model
Printer.MODEL_CHINESE	Simplified Chinese model
Printer.MODEL_TAIWAN	Taiwan model
Printer.MODEL_KOREAN	Korean model
Printer.MODEL_THAI	Thai model
Printer.MODEL_SOUTHASIA	South Asian model

context

Specifies the application context.

Null can be specified when the log output function is not used and the printer is not connected via USB.

Exception

When the process fails, Epos2Exception with one of the following error value occurs.

Error status	Description
ERR_PARAM	An invalid parameter was passed.
ERR_MEMORY	Memory necessary for processing could not be allocated.
ERR_UNSUPPORTED	A model name or language not supported was specified.

Supplementary explanation

When iterating a process, be sure to generate and destroy instances outside the iterated process and not iterate the process at a short interval.

Memory releasing by the OS may affect the process of the Epson ePOS SDK, resulting in an invalid operation.

When using it with multiple printers connected, make sure to generate a dedicated instance for each printer.

connect

Starts communication with the printer.

Syntax

Public void connect(String target, int timeout) throws Epos2Exception

Parameter

target

Specifies the method of connecting to the printer by a character string.

The connection method varies according to the system configuration.

- TM Printer Models

<connection type>:<identifier>

I/F	Connection type	Identifier	Example
Wi-Fi/Ethernet	"TCP"	<ul style="list-style-type: none"> IP address in IPv4 format MAC address Host name 	"TCP:192.168.192.168"
<i>Bluetooth</i>	"BT"	BD address	"BT:00:22:15:7D:70:9C"
USB	"USB"	<ul style="list-style-type: none"> Device node Serial number Omitted 	"USB:/dev/udev/*" "USB:00000000000000000000" "USB:"

- Customer Display Models

<connection type>:<identifier>

I/F	Connection type	Identifier	Example
Wi-Fi/Ethernet	"TCP"	<ul style="list-style-type: none"> IP address in IPv4 format MAC address Host name 	"TCP:192.168.192.168"
<i>Bluetooth</i>	"BT"	BD address	"BT:00:22:15:7D:70:9C"
USB	"USB"	<ul style="list-style-type: none"> Device node Serial number Omitted 	"USB:/dev/udev/*" "USB:00000000000000000000" "USB:"

To connect to the printer via SSL/TLS communication, specify using the following syntax.

<connection type>:<identifier>[<device ID>]

I/F	Connection type	Identifier	Example
Wi-Fi/Ethernet	"TCPS"	<ul style="list-style-type: none"> IP address in IPv4 format MAC address Host name 	"TCPS:192.168.192.168[local_printer]"

- TM Printer + DM-D30 + barcode scanner model/
TM Printer + barcode scanner model

To connect via Wi-Fi/Ethernet network communication, specify using the following syntax.

<connection type>:<identifier>[<device ID>]

I/F	Connection type	Identifier	Example
Wi-Fi/Ethernet	"TCP"	<ul style="list-style-type: none"> IP address in IPv4 format MAC address Host name 	"TCP:192.168.192.168[local_printer]"

The device ID is fixed as [local_printer].

To connect via *Bluetooth* or USB, specify using the following syntax.

<connection type>:<identifier>

I/F	Connection type	Identifier	Example
<i>Bluetooth</i>	"BT"	BD address	"BT:00:22:15:7D:70:9C"
USB	"USB"	<ul style="list-style-type: none"> Device node Serial number Omitted 	"USB:/dev/udev/*" "USB:00000000000000000000" "USB:"

- POS Terminal Model

<connection type>:<identifier>[<device ID>]

I/F	Connection type	Identifier	Example
Wi-Fi/Ethernet	<ul style="list-style-type: none"> "TCP" "TCPS" 	<ul style="list-style-type: none"> IP address in IPv4 format MAC address Host name 	"TCP:192.168.192.168[local_printer]"

To connect to the printer via SSL/TLS communication, specify TCPS in the connection type.

timeout

Specifies the maximum time (in milliseconds) to wait for communication with the printer to be established.

Value	Description
Integer from 1000 to 300000	Maximum wait time before an error is returned (in milliseconds).
Print.PARAM_DEFAULT	Specifies the default value (15000).

Exception

When the process fails, Epos2Exception with one of the following error value occurs.

Error status	Description
ERR_PARAM	An invalid parameter was passed.
ERR_CONNECT	Failed to open the device.
ERR_TIMEOUT	Failed to communicate with the devices within the specified time.
ERR_ILLEGAL	Tried to start communication with a printer with which communication had been already established.
ERR_MEMORY	Necessary memory could not be allocated.
ERR_FAILURE	An unknown error occurred.
ERR_PROCESSING	Could not run the process.
ERR_NOT_FOUND	The device could not be found.
ERR_IN_USE	The device was in use.
ERR_TYPE_INVALID	The device type is different.

Supplementary explanation

- ❑ When communication with the printer is no longer necessary, be sure to call [disconnect](#) to terminate it.
- ❑ When using multi-threading to connect to multiple printers or peripheral devices, this API and [disconnect](#) cannot be started for other printers or peripheral devices until this API finishes processing. Start the next process after this API finishes processing.
- ❑ The printer status is returned to the event registered with the Printer class.
For details, refer to Chapter 2 "Programming Flow" and Chapter 6 "To use the same printer from multiple mobile devices."
- ❑ The device ID is an arbitrary character string that is set when the peripheral device is registered to the TM printer (master).
For details, refer to the Technical Reference Guide of each printer.
- ❑ If you are using DHCP to assign the IP address of the printer, specify the MAC address or host name of the printer as the identifier.
- ❑ If you specify the host name of the printer as the identifier, use in the environment where it can be found by the DNS server.

- ❑ When connecting through the USB, the identifiers that can be specified differ depending on the shape of the USB connector.

When the identifier is omitted, Android OS connects with the USB device found first.

When the Android terminal is set to the developer mode, you may not be able to connect through USB-A - Device Charging.

Identifier	Shape of the USB connector	
	USB-B	USB-A - Device Charging
Device node	✓	-
Serial number	-	✓
Omitted	✓	✓

- ❑ This API will succeed regardless of the connection status of the TM printer (master) and peripheral devices.
- ❑ Devices other than printers are exclusively locked.

disconnect

Ends communication with the printer.

Syntax

Public void disconnect() throws Epos2Exception

Exception

When the process fails, Epos2Exception with one of the following error value occurs.

Error status	Description
ERR_ILLEGAL	Tried to end communication where it had not been established.
ERR_MEMORY	Necessary memory could not be allocated.
ERR_FAILURE	An unknown error occurred.
ERR_PROCESSING	Could not run the process.
ERR_DISCONNECT	Failed to disconnect the device.

Supplementary explanation

When using multi-threading to connect to multiple printers or peripheral devices, this API and [connect](#) cannot be started for other printers or peripheral devices until this API finishes processing.

startMonitor

Enables printer status event notification.

Acquires and updates the printer status at the interval specified with the [interval](#) property and notifies it of the listener registration method registered by [setStatusChangeListener](#).

Syntax

```
public void startMonitor() throws Epos2Exception
```

Exception

When the process fails, Epos2Exception with one of the following error value occurs.

Error status	Description
ERR_ILLEGAL	This API was called while no communication had been started.

Supplementary explanation

- ❑ Use this API after starting a communication with the printer (after executing the [connect](#) API).
- ❑ During ESC/POS control, any ASB information items which have been changed during the update [interval](#) specified by the interval property are reported.
During ePOS-Device XML control, the ASB information at the time of update is reported.

stopMonitor

Disables status events.

Syntax

```
public void stopMonitor() throws Epos2Exception
```

Exception

When the process fails, Epos2Exception with one of the following error value occurs.

Error status	Description
ERR_ILLEGAL	This API was called while no communication had been started.

getStatus

Acquires the current status information.

Syntax

```
public PrinterStatusInfo getStatus ()
```

Return value

The current status is returned in the PrinterStatusInfo type.

The following status information is stored in the object as a property.

Stored status information can be acquired using the getter method of each property.

Printer status	Status	Description
connection: Connection status	Printer.TRUE	Connected
	Printer.FALSE	Status is unknown.
online: Online status	Printer.TRUE	Online
	Printer.FALSE	Offline
	Printer.UNKNOWN	Status is unknown.
coverOpen: Cover status	Printer.TRUE	Cover is open.
	Printer.FALSE	Cover is closed.
	Printer.UNKNOWN	Status is unknown.
paper: Paper status	Printer.PAPER_OK	Paper remains.
	Printer.PAPER_NEAR_END	Paper is running out.
	Printer.PAPER_EMPTY	Paper has run out.
	Printer.UNKNOWN	Status is unknown.
paperFeed: Paper feed	Printer.TRUE	Paper feed in progress
	Printer.FALSE	Stopped
	Printer.UNKNOWN	Status is unknown.
panelSwitch: Panel switch (Feed button) status	Printer.SWITCH_ON	Pressed
	Printer.SWITCH_OFF	Not pressed
	Printer.UNKNOWN	Status is unknown.
drawer: Offline status due to the battery level (Mobile models)	Printer.DRAWER_HIGH	High
	Printer.DRAWER_LOW	Low
	Printer.UNKNOWN	Status is unknown.

Printer status	Status	Description
drawer: Drawer kick connector pin No.3 status (except for the Mobile models)	Printer.DRAWER_HIGH	High
	Printer.DRAWER_LOW	Low
	Printer.UNKNOWN	Status is unknown.
errorStatus: Error status	Printer.NO_ERR	Normal
	Printer.MECHANICAL_ERR	Mechanical error occurred.
	Printer.AUTOCUTTER_ERR	Auto cutter error occurred.
	Printer.UNRECOVER_ERR	Unrecoverable error occurred.
	Printer.AUTORECOVER_ERR	Automatic recovery error occurred.
	Printer.UNKNOWN	Status is unknown.
autoRecoverError: Automatic recovery error status	Printer.HEAD OVERHEAT	Head overheat error
	Printer.MOTOR OVERHEAT	Motor driver IC overheat error
	Printer.BATTERY OVERHEAT	Battery overheat error
	Printer.WRONG PAPER	Paper error
	Printer.COVER_OPEN	Cover is open.
	Printer.UNKNOWN	Unknown status
buzzer: Buzzer sound status	Printer.TRUE	Sounding (Applicable printer only)
	Printer.FALSE	Stopped (Applicable printer only)
	Printer.UNKNOWN	Status is unknown.
adapter: AC adapter connection status	Printer.TRUE	Connected
	Printer.FALSE	Disconnected
	Printer.UNKNOWN	Status is unknown.
batteryLevel: Remaining battery capacity	Printer.BATTERY_LEVEL_6	Remaining battery capacity 6
	Printer.BATTERY_LEVEL_5	Remaining battery capacity 5
	Printer.BATTERY_LEVEL_4	Remaining battery capacity 4
	Printer.BATTERY_LEVEL_3	Remaining battery capacity 3
	Printer.BATTERY_LEVEL_2	Remaining battery capacity 2
	Printer.BATTERY_LEVEL_1	Remaining battery capacity 1 (almost run out)
	Printer.BATTERY_LEVEL_0	Remaining battery capacity 0 (run out)
	Printer.UNKNOWN	Status is unknown.

Supplementary explanation

- ❑ If this API is called while communication is not available, printer states other than "connection" will be set to "Printer.UNKNOWN."
- ❑ The status object is set to the status at the timing of execution of this API and will not be updated.

sendData

Sends the print command.

The error status of this API is the result of sending data to the devices.

The processing result of the devices using this API is notified to the listener registration method set by the [setReceiveEventListener](#) API of the Printer class.

Make sure not to use this API repeatedly without getting the result in the callback.

This API sends data buffered by an add-type API (e.g., [addText](#)).

Syntax

```
public void sendData (int timeout) throws Epos2Exception
```

Parameter

timeout

Specifies the timeout period before completion of printing in milliseconds.

Value	Description
Integer from 5000 to 600000	Timeout period (in milliseconds)
Printer.PARAM_DEFAULT	Specifies the default value (10000).

Exception

When the process fails, Epos2Exception with one of the following error value occurs.

Error status	Description
ERR_PARAM	An invalid parameter was passed.
ERR_MEMORY	Necessary memory could not be allocated.
ERR_FAILURE	An unknown error occurred.
ERR_PROCESSING	Could not run the process.
ERR_ILLEGAL	The control commands have not been buffered. This API was called while no communication had been started.

Supplementary explanation

For *Bluetooth* connection, the offline status may not be detected and a timeout error may occur.

Refer to Chapter 6 "To use the same printer from multiple mobile devices" for details.

beginTransaction

Starts a transaction.

A transaction represents a single printing task such as printing a single sheet of receipt or coupon.

After this API is called, data until the transaction is terminated by [endTransaction](#) will be regarded as a single printing task.

Syntax

```
public void beginTransaction() throws Epos2Exception
```

Exception

When the process fails, Epos2Exception with one of the following error status occurs.

Error status	Description
ERR_ILLEGAL	This API was called while no communication had been started. Another transaction had been already started by this function.
ERR_FAILURE	An unknown error occurred.

endTransaction

Ends a transaction.

A transaction represents a single printing task such as printing a single sheet of receipt or coupon.

After [beginTransaction](#) is called, data until the transaction is terminated by this API will be regarded as a single printing task.

Syntax

```
public void endTransaction() throws Eswv2Exception
```

Exception

When the process fails, Epos2Exception with one of the following error status occurs.

Error status	Description
ERR_ILLEGAL	This API was called while no communication had been started. This API was called while no transaction had been started.
ERR_FAILURE	An unknown error occurred.

requestPrintJobStatus

Acquires the print result for the specified print job ID.

Syntax

```
public void requestPrintJobStatus (String printJobId) throws
Epos2Exception
```

Parameter

printJobId

Specifies the print job ID.

Alphanumeric characters, underscore, hyphen, and period in 1 to 30 digits can be used.

Exception

When the process fails, Epos2Exception with one of the following error status occurs.

Error status	Description
ERR_CONNECT	Communication error
ERR_PARAM	An invalid parameter was passed.
ERR_MEMORY	Necessary memory could not be allocated.
ERR_FAILURE	An unknown error occurred.
ERR_PROCESSING	Could not run the process.

Supplementary explanation

- ❑ The result of this API is notified to the listener registration method set by the [setReceiveEventListener](#) API of the Printer class.
- ❑ When multiple print processes were performed with the same print job ID, the status of the latest print job is acquired.

clearCommandBuffer

Clears the command buffer.

The contents buffered in the command buffer are retained until this API is called.

Syntax

```
public void clearCommandBuffer()
```

addTextAlign

Adds text alignment setting to the command buffer.

Syntax

```
public void addTextAlign(int align) throws Epos2Exception
```

Parameter

align

Specifies alignment.

Value	Description
Printer.ALIGN_LEFT (default)	Left alignment
Printer.ALIGN_CENTER	Center alignment
Printer.ALIGN_RIGHT	Right alignment
Printer.PARAM_DEFAULT	Specifies the default value (left alignment).

Exception

When the process fails, Epos2Exception with one of the following error status occurs.

Error status	Description
ERR_PARAM	An invalid parameter was passed.
ERR_MEMORY	Memory necessary for processing could not be allocated.
ERR_FAILURE	An unknown error occurred.

Supplementary explanation

- ❑ Use this API at the "beginning of a line." If this API is used elsewhere, it will be ignored.
- ❑ Setting of this API is also applied to the barcode/2D symbol.
- ❑ When specifying alignment in the page mode, use [addPagePosition](#) instead of this API.

addLineSpace

Adds line spacing setting to the command buffer.

Syntax

```
public void addLineSpace(int linespc) throws Epos2Exception
```

Parameter

linespc

Specifies the line spacing (in dots).

Value	Description
Integer from 0 to 255	Line spacing (in dots)

Exception

When the process fails, Epos2Exception with one of the following error status occurs.

Error status	Description
ERR_PARAM	An invalid parameter was passed.
ERR_MEMORY	Memory necessary for processing could not be allocated.
ERR_FAILURE	An unknown error occurred.

Supplementary explanation

If the line spacing for a single line is set smaller than the print character size, paper may be fed for a larger quantity than the set amount to ensure proper printing.

addTextRotate

Adds text rotation setting to the command buffer.

Syntax

```
public void addTextRotate(int rotate) throws Epos2Exception
```

Parameter

rotate

Enables or disables text rotation.

Value	Description
Printer.TRUE	Specifies text rotation.
Printer.FALSE (default)	Disables text rotation.
Printer.PARAM_DEFAULT	Specifies the default value (text rotation disabled).

Exception

When the process fails, Epos2Exception with one of the following error status occurs.

Error status	Description
ERR_PARAM	An invalid parameter was passed.
ERR_MEMORY	Memory necessary for processing could not be allocated.
ERR_FAILURE	An unknown error occurred.

Supplementary explanation

- ❑ Use this API at the "beginning of a line." If this API is used elsewhere, it will be ignored.
- ❑ Setting of this API is also applied to the barcode/2D symbol.
- ❑ When specifying text rotation in the page mode, use [addPageDirection](#) instead of this API.

addText

Adds a character print command to the command buffer.

Syntax

```
public void addText(String data) throws Epos2Exception
```

Parameter

data

Specifies the string to print.

Use the following escape sequences for a horizontal tab and line feed.

String	Description
\t	Horizontal tab (HT)
\h	Line feed (LF)
\\	Back slash

Exception

When the process fails, Epos2Exception with one of the following error status occurs.

Error status	Description
ERR_PARAM	An invalid parameter was passed.
ERR_MEMORY	Memory necessary for processing could not be allocated.
ERR_FAILURE	An unknown error occurred.

Supplementary explanation

- ❑ To print data other than text after printing text, feed a line or page.
A line which does not end with a line feed will be discarded as unfixed data by the next [sendData](#).
- ❑ In the page mode, text is printed from the current print position with the base line dot of the characters as the standard.

addTextLang

Adds language setting to the command buffer.

A text string specified by the [addText](#) API is encoded according to the language specified by this API.

Syntax

```
public void addTextLang(int lang) throws Epos2Exception
```

Parameter

lang

Specifies the target language.

Value	Description
Printer.LANG_EN (default)	English (ANK specification)
Printer.LANG_JA	Japanese
Printer.LANG_ZH_CN	Simplified Chinese
Printer.LANG_ZH_TW	Traditional Chinese
Printer.LANG_KO	Korean
Printer.LANG_TH	Thai (South Asian specification)
Printer.LANG_VI	Vietnamese (South Asian specification)
Printer.LANG_MULTI	Multiple languages (UTF-8)
Printer.PARAM_DEFAULT	Specifies the default value (English).

Exception

When the process fails, Epos2Exception with one of the following error status occurs.

Error status	Description
ERR_PARAM	An invalid parameter was passed.
ERR_MEMORY	Memory necessary for processing could not be allocated.
ERR_FAILURE	An unknown error occurred.

Supplementary explanation

- ❑ This API is called before the [addText](#) API.
- ❑ Available languages differ depending on character specifications of the printer. For details, see Technical Reference Guide of the printer.

addTextFont

Adds character font setting to the command buffer.

Syntax

```
public void addTextFont(int font) throws Epos2Exception
```

Parameter

font

Specifies the font.

Value	Description
Printer.FONT_A (default)	Font A
Printer.FONT_B	Font B
Printer.FONT_C	Font C
Printer.FONT_D	Font D
Printer.FONT_E	Font E
Printer.PARAM_DEFAULT	Specifies the default value (font A).

Exception

When the process fails, Epos2Exception with one of the following error status occurs.

Error status	Description
ERR_PARAM	An invalid parameter was passed.
ERR_MEMORY	Memory necessary for processing could not be allocated.
ERR_FAILURE	An unknown error occurred.

addTextSmooth

Adds smoothing setting to the command buffer.

Syntax

```
public void addTextSmooth(int smooth) throws
Epos2Exception
```

Parameter

smooth

Enables or disables smoothing.

Value	Description
Printer.TRUE	Enables smoothing.
Printer.FALSE (default)	Disables smoothing.
Printer.PARAM_DEFAULT	Specifies the default value (smoothing disabled).

Exception

When the process fails, Epos2Exception with one of the following error status occurs.

Error status	Description
ERR_PARAM	An invalid parameter was passed.
ERR_MEMORY	Memory necessary for processing could not be allocated.
ERR_FAILURE	An unknown error occurred.

addTextSize

Adds character scaling factor setting to the command buffer.

Syntax

```
public void addTextSize(int width, int height) throws
Epos2Exception
```

Parameter

width

Specifies the horizontal scaling of characters.

Value	Description
Integer from 1 to 8	Specifies the horizontal scaling factor rate (default: 1).
Printer.PARAM_DEFAULT	Specifies the default value (1).
Printer.PARAM_UNSPECIFIED	<Obsolete> Not specify.

height

Specifies the vertical scaling of characters.

Value	Description
Integer from 1 to 8	Specifies the vertical scaling factor rate (default: 1).
Printer.PARAM_DEFAULT	Specifies the default value (1).
Printer.PARAM_UNSPECIFIED	<Obsolete> Not specify.

Exception

When the process fails, Epos2Exception with one of the following error status occurs.

Error status	Description
ERR_PARAM	An invalid parameter was passed.
ERR_MEMORY	Memory necessary for processing could not be allocated.
ERR_FAILURE	An unknown error occurred.

Supplementary explanation

- ❑ If all the parameters are set to "Printer.PARAM_UNSPECIFIED," ERR_PARAM will be returned.
- ❑ For slip, endorsement, or validation printing, an integer from 1 to 2 can be set for the width and height.

addTextStyle

Adds character style setting to the command buffer.

Syntax

```
public void addTextStyle(int reverse, int ul, int em, int color)
throws Epos2Exception
```

Parameter

reverse

Enables or disables the reverse style.

Value	Description
Printer.TRUE	Enables the reverse style.
Printer.FALSE (default)	Disables the reverse style.
Printer.PARAM_UNSPECIFIED	<Obsolete> Not specify.
Printer.PARAM_DEFAULT	Specifies the default value (reverse style disabled).

ul

Enables or disables the underscore style.

Value	Description
Printer.TRUE	Enables the underscore style.
Printer.FALSE (default)	Disables the underscore style.
Printer.PARAM_UNSPECIFIED	<Obsolete> Not specify.
Printer.PARAM_DEFAULT	Specifies the default value (underscore style disabled).

em

Enables or disables the bold style..

Value	Description
Printer.TRUE	Enables the bold style.
Printer.FALSE (default)	Disables the bold style.
Printer.PARAM_UNSPECIFIED	<Obsolete> Not specify.
Printer.PARAM_DEFAULT	Specifies the default value (bold style disabled).

color

Specifies the color.

Value	Description
Printer.COLOR_NONE	No printing

Value	Description
Printer.COLOR_1 (default)	First color
Printer.COLOR_2	Second color
Printer.COLOR_3	Third color
Printer.COLOR_4	Fourth color
Printer.PARAM_UNSPECIFIED	<Obsolete> Not specify.
Printer.PARAM_DEFAULT	Specifies the default value (first color).

Exception

When the process fails, Epos2Exception with one of the following error status occurs.

Error status	Description
ERR_PARAM	An invalid parameter was passed.
ERR_MEMORY	Memory necessary for processing could not be allocated.
ERR_FAILURE	An unknown error occurred.

Supplementary explanation

If all the parameters are set to "Printer.PARAM_UNSPECIFIED," ERR_PARAM will be returned.

addHPosition

Adds horizontal character print start position to the command buffer.

Syntax

```
public void addHPosition(int x) throws Epos2Exception
```

Parameter

x

Specifies the horizontal print start position in dots.

Value	Description
Integer from 0 to 65535	Horizontal print start position (in dots)

Exception

When the process fails, Epos2Exception with one of the following error status occurs.

Error status	Description
ERR_PARAM	An invalid parameter was passed.
ERR_MEMORY	Memory necessary for processing could not be allocated.
ERR_FAILURE	An unknown error occurred.

Supplementary explanation

- ❑ Calling this API causes the printer positioned at "other than the beginning of the line."
This is also true even if 0 is set to "X."
- ❑ After executing this API, [addTextAlign](#) and [addTextRotate](#) cannot be used.

addFeedUnit

Adds a paper-feed-by-dot command to the command buffer.

Syntax

```
public void addFeedUnit(int unit) throws Epos2Exception
```

Parameter

unit

Specifies the paper feed amount (in dots).

Value	Description
Integer from 0 to 255	Paper feed amount (in dots)

Exception

When the process fails, Epos2Exception with one of the following error status occurs.

Error status	Description
ERR_PARAM	An invalid parameter was passed.
ERR_MEMORY	Memory necessary for processing could not be allocated.
ERR_FAILURE	An unknown error occurred.

Supplementary explanation

Calling this API causes the printer positioned at "the beginning of the line."

addFeedLine

Adds a paper-feed-by-line command to the command buffer.

Syntax

```
public void addFeedLine(int line) throws Epos2Exception
```

Parameter

line

Specifies the paper feed amount (in lines).

Value	Description
Integer from 0 to 255	Paper feed amount (in lines)

Exception

When the process fails, Epos2Exception with one of the following error status occurs.

Error status	Description
ERR_PARAM	An invalid parameter was passed.
ERR_MEMORY	Memory necessary for processing could not be allocated.
ERR_FAILURE	An unknown error occurred.

Supplementary explanation

Calling this API causes the printer positioned at "the beginning of the line."

addImage

Adds a raster image print command to the command buffer.

Prints Android.graphics.Bitmap class graphics.

A specified area of Android.graphics.Bitmap class graphics is binarized according to the mode, halftone, and brightness parameters and converted into a raster image.

The converted image is compressed or not compressed before transmission according to the compress parameter value.

One pixel of an image corresponds to one dot of the printer. When a transparent color is contained in the image, the background of the image is assumed to be white.

Syntax

```
public void addImage(Bitmap data, int x, int y, int width, int height, int color, int mode, int halftone, double brightness, int compress) throws Epos2Exception
```

Parameter

data

Specifies an instance of the android.graphics.Bitmap class.

x

Specifies the horizontal start position of the print area (in pixels).

Value	Description
Integer from 0 to 65534	Horizontal start position of the print area (in pixels)

y

Specifies the vertical start position of the print area (in pixels).

Value	Description
Integer from 0 to 65534	Vertical start position of the print area (in pixels)

width

Specifies the width of the print area (in pixels).

Value	Description
Integer from 1 to 65535	Width of the print area (in pixels).

height

Specifies the height of the print area (in pixels).

Value	Description
Integer from 1 to 65535	Height of the print area (in pixels).

color

Specifies the color.

Value	Description
Printer.COLOR_NONE	No printing
Printer.COLOR_1	First color
Printer.COLOR_2	Second color
Printer.COLOR_3	Third color
Printer.COLOR_4	Fourth color
Printer.PARAM_DEFAULT	Specifies the default value (first color).

mode

Specifies the color mode.

Value	Description
Printer.MODE_MONO	Monochrome (2 scales)
Printer.MODE_GRAY16	Multi-gradation (16 scales)
Printer.MODE_MONO_HIGH_DENSITY	Monochrome (2 scales), double density
Printer.PARAM_DEFAULT	Specifies the default (monochrome (2 scales)).

halftone

Specifies the halftone processing method.

Value	Description
Printer.HALFTONE_DITHER	Dithering (appropriate for printing graphics only)
Printer.HALFTONE_ERROR_DIFFUSION	Error diffusion (appropriate for printing text and graphics)
Printer.HALFTONE_THRESHOLD	Threshold (appropriate for printing text only)
Printer.PARAM_DEFAULT	Specifies the default (dithering).

Effective for the monochrome (2 scales) color mode only.

brightness

Specifies the brightness compensation value.

Value	Description
Real number from 0.1 to 10.0	Brightness compensation (gamma correction) value
Printer.PARAM_DEFAULT	Default (1.0)

When a value other than 1.0 is specified for the brightness compensation value, processing gets slower.

compress

Enables or disables compression.

Compressing print images can prevent white banding or streaks from occurring on printed images.

This works well when connecting with the printer using *Bluetooth*.

Value	Description
Printer.COMPRESS_DEFLATE	Compresses the image.
Printer.COMPRESS_NONE	Does not compress the image.
Printer.COMPRESS_AUTO	Automatically chooses to or not to compress the image internally.
Printer.PARAM_DEFAULT	Default (automatically chooses to or not to compress the image internally)

Exception

When the process fails, Epos2Exception with one of the following error status occurs.

Error status	Description
ERR_PARAM	An invalid parameter was passed.
ERR_MEMORY	Memory necessary for processing could not be allocated.
ERR_FAILURE	An unknown error occurred.

Supplementary explanation

- If the area specified by x/y and width/height parameters does not fit within the image size specified by data parameter, ERR_PARAM will be returned as an exception.
- Compress can only be specified with the *Bluetooth* model of the following printers. For other printers, specify Printer.COMPRESS_AUTO.

Model	Firmware version
TM-m10	No restriction
TM-m30	No restriction
TM-m30II/TM-m30II-H	No restriction
TM-P20	No restriction
TM-P60II (Receipt)	5.14 ESC/POS or later
TM-P60II (Peeler)	6.14 ESC/POS or later
TM-P80	1.02 ESC/POS or later
TM-P80AC	2.01 ESC/POS or later
TM-T20II	No restriction
TM-T20III	No restriction
TM-T70II	No restriction
TM-T82III	No restriction
TM-T88V	No restriction

Model	Firmware version
TM-T88VI	No restriction

- ❑ Printing may get slower if a transparent image is printed.
- ❑ The multi-gradation and the compression of image data are not supported in the page mode. If you set those in the page mode, nothing will be printed.
- ❑ Set an image size appropriate for the printer. If you set to print a large image, the API commands will be succeeded, but the printer may print nothing.
- ❑ Even if the size of an image is printable, the ERR_MEMORY error may occur depending on the Android device specification. In such case, reduce the image size.

addLogo

Adds a NV logo print command to the command buffer.
Prints the logo registered in the NV memory of the printer.

Syntax

```
public void addLogo(int key1, int key2) throws
Epos2Exception
```

Parameter

key1

Specifies the key code 1 of the NV logo.

Value	Description
Integer from 1 to 255	Key code 1 of the NV logo

key2

Specifies the key code 2 of the NV logo.

Value	Description
Integer from 1 to 255	Key code 2 of the NV logo
Printer.PARAM_DEFAULT	Specify this for the printers that do not support key code 2.

Exception

When the process fails, Epos2Exception with one of the following error status occurs.

Error status	Description
ERR_PARAM	An invalid parameter was passed.
ERR_MEMORY	Memory necessary for processing could not be allocated.
ERR_FAILURE	An unknown error occurred.

Supplementary explanation

- ❑ For how to register the NV logo, refer to the Technical Reference Guide of the printer.
- ❑ The page mode does not support multi-gradation printing. Multi-gradation graphics can be printed in the standard mode only.
- ❑ The NV logo specified by this API is printed with the color setting specified by [addTextStyle](#) buffered in advance.
- ❑ TM-U220 and TM-U330 use only the key1 parameter, however, you need to set "Printer.PARAM_DEFAULT" as the key2 parameter for those printers since an empty key2 parameter causes an error.

addBarcode

Adds a barcode print command to the command buffer.

Syntax

```
public void addBarcode(String data, int type, int hri, int font,
int width, int height) throws Epos2Exception
```

Parameter

data

Specifies barcode data as a text string.

Specify a string in accordance with the standard of the barcode specified in type.

Type	Description
UPC-A	If an 11-digit figure is specified, the check digit is automatically appended. If a 12-digit figure is specified, the 12th digit is used as the check digit but verification is not performed.
UPC-E	Specify 0 in the first digit. Specify the manufacturer code in the 2nd to 6th digits. Specify the item code in right justification in the 7th to 11th digits. The number of digits of the item code depends on the manufacturer code. Specify 0 in each unused data. If an 11-digit figure is specified, the check digit is automatically appended. If a 12-digit figure is specified, the 12th digit is used as the check digit but verification is not performed.
EAN13	If an 12-digit figure is specified, the check digit is automatically appended.
JAN13	If a 13-digit figure is specified, the 13th digit is used as the check digit but verification is not performed.
EAN8	If an 7-digit figure is specified, the check digit is automatically appended.
JAN8	If an 8-digit figure is specified, the 8th digit is used as the check digit but verification is not performed.
CODE39	If the first character is *, this character is processed as the start character. If it is not , the start character is automatically added.
ITF	The start and stop codes are automatically added. Addition and verification of the check digit are not performed.
CODABAR	Specify the start character ((A to D, a to d). Specify the stop character ((A to D, a to d). Addition and verification of the check digit are not performed.
CODE93	The start and stop characters are automatically added. The check digit is automatically calculated and added.

Type	Description
CODE128	<p>Specify the start character (CODE A, CODE B, CODE C). The stop character is automatically added. The check digit is automatically calculated and added. To encode the following characters, specify the corresponding 2-digit code starting with { :</p> <ul style="list-style-type: none"> • FNC1: {1 • FNC2: {2 • FNC3: {3 • FNC4: {4 • CODE A: {A • CODE B: {B • CODE C: {C • SHIFT: {S • {: {{ <p>When specifying CODE C, specify the barcode data as the control code of the escape sequence.</p>
GS1-128	<p>The start character, FNC1, check digit, and stop characters are automatically added. However, FNC1 used as a data separator is not added. To automatically calculate and add the application ID (AI) and the following check digit, specify "*" at the check digit position. The application ID (AI) can be put in parentheses. The parentheses are used as print characters for HRI and not encoded as data. A blank space can be inserted between the application ID (AI) and data. The blank space is used as print characters for HRI and not encoded as data. To encode the following characters, specify the corresponding 2-digit code starting with { :</p> <ul style="list-style-type: none"> • FNC1: {1 • FNC3: {3 • (: {{ •): {} • FNC1: {1 • {: {{
GS1 DataBar Omnidirectional	Specify a 13-digit product ID (GTIN) excluding the application ID (AI) and check digit.
GS1 DataBar Truncated	
GS1 DataBar Limited	
GS1 DataBar Expanded	<p>The application ID (AI) can be put in parentheses. The parentheses are used as print characters for HRI and not encoded as data. To encode the following characters, specify the corresponding 2-digit code starting with { :</p> <ul style="list-style-type: none"> • FNC1: {1 • (: {{ •): {}

When specifying binary data which cannot be represented as a string, use the following escape sequences.

String	Description
\xnn	Control code (set nn in hexadecimal)
\\	Back slash

type

Specifies the barcode type.

Value	Description
Printer.BARCODE_UPC_A	UPC-A
Printer.BARCODE_UPC_E	UPC-E
Printer.BARCODE_EAN13	EAN13
Printer.BARCODE_JAN13	JAN13
Printer.BARCODE_EAN8	EAN8
Printer.BARCODE_JAN8	JAN8
Printer.BARCODE_CODE39	CODE39
Printer.BARCODE_ITF	ITF
Printer.BARCODE_CODABAR	CODABAR
Printer.BARCODE_CODE93	CODE93
Printer.BARCODE_CODE128	CODE128
Printer.BARCODE_GS1_128	GS1-128
Printer.BARCODE_GS1_DATABAR_OMNIDIRECTIONAL	GS1 DataBar Omnidirectional
Printer.BARCODE_GS1_DATABAR_TRUNCATED	GS1 DataBar Truncated
Printer.BARCODE_GS1_DATABAR_LIMITED	GS1 DataBar Limited
Printer.BARCODE_GS1_DATABAR_EXPANDED	GS1 DataBar Expanded

hri

Specifies the HRI position.

Value	Description
Printer.HRI_NONE (default)	No printing.
Printer.HRI_ABOVE	Above the barcode
Printer.HRI_BELOW	Below the barcode
Printer.HRI_BOTH	Both above and below the barcode
Printer.PARAM_DEFAULT	Specifies the default value (no printing).
Printer.PARAM_UNSPECIFIED	<Obsolete> Not specify.

font

Specifies the HRI font.

Value	Description
Printer.FONT_A (default)	Font A
Printer.FONT_B	Font B
Printer.FONT_C	Font C
Printer.FONT_D	Font D
Printer.FONT_E	Font E
Printer.PARAM_DEFAULT	Specifies the default value (font A).
Printer.PARAM_UNSPECIFIED	<Obsolete> Not specify.

width

Specifies the width of a single module in dots.

Value	Description
Integer from 2 to 6	Width of a single module (in dots)
Printer.PARAM_UNSPECIFIED	<Obsolete> Not specify.

height

Specifies the height of the barcode in dots.

Value	Description
Integer from 1 to 255	Height of the barcode (in dots)
Printer.PARAM_UNSPECIFIED	<Obsolete> Not specify.

Exception

When the process fails, Epos2Exception with one of the following error status occurs.

Error status	Description
ERR_PARAM	An invalid parameter was passed.
ERR_MEMORY	Memory necessary for processing could not be allocated.
ERR_FAILURE	An unknown error occurred.

Supplementary explanation

- ❑ Use this API at the "beginning of a line."
- ❑ When the barcode data specified in data does not conform to the barcode type specified in type, an error will not be returned as an exception and the barcode will not be printed.

addSymbol

Adds a 2D symbol print command to the command buffer.

Syntax

```
public void addSymbol(String data, int type, int level, int width, int height, int size) throws Epos2Exception
```

Parameter

data

Specifies 2D symbol data as a text string.

Specify a string in accordance with the standard of the 2D symbol specified in type.

Type	Description
Standard PDF417	Converts the string into UTF-8, processes the escape sequence(s), and encodes the data.
Truncated PDF417	The maximum number of code words in the data area is 928, the maximum number of code words in a single stage is 30, and the maximum number of stages is 90.
QR Code Model 1	Converts the string into JIS, processes the escape sequence(s), and encodes the data by choosing the data type from the following: <ul style="list-style-type: none"> • Figure: 0 to 9 • Alphanumeric: 0 to 9, A to Z, space, \$, %, *, +, -, ., /, : • Kanji: Characters which can be represented with Shift JIS codes • 8-bit byte data: 0x00 to 0xff
QR Code Model 2	
QR Code Micro	
MaxiCode Mode 2	Converts the string into UTF-8, processes the escape sequence(s), and encodes the data. In Mode 2 or 3, if the first data is []>\x1e01\x1dyy ("yy" is a 2-digit figure), this is processed as the message header and the second and succeeding data sequence is processed as the primary message. Otherwise, the primary message starts with the first data. For the mode 2, specify the primary message in the following format: <ul style="list-style-type: none"> • Zip code (1- to 9-digit figure) GS:(\x1d) • ISO country code (1- to 3-digit figure) GS:(\x1d) • Service class code (1- to 3-digit figure) For the mode 3, specify the primary message in the following format: <ul style="list-style-type: none"> • Zip code (data which can be converted with 1 to 6 code sets A) GS (\x1d) • ISO country code (1- to 3-digit figure) GS (\x1d) • Service class code (1- to 3-digit figure)
MaxiCode Mode 3	
MaxiCode Mode 4	
MaxiCode Mode 5	
MaxiCode Mode 6	
GS1 DataBar Stacked	Converts the string into UTF-8, processes the escape sequence(s), and encodes the data. Specify a 13-digit product ID (GTIN) excluding the application ID (AI) and check digit.
GS1 DataBar Stacked Omnidirectional	

Type	Description
GS1 DataBar Expanded Stacked	<p>Converts the string into UTF-8, processes the escape sequence(s), and encodes the data.</p> <p>The application ID (AI) can be put in parentheses.</p> <p>The parentheses are used as print characters for HRI and not encoded as data.</p> <p>To encode the following characters, specify the corresponding 2-digit code starting with { :</p> <ul style="list-style-type: none"> • FNC1: {1 • (: {(•): })
Aztec Code	Converts the string into UTF-8, processes the escape sequence(s), and encodes the data.
DataMatrix	Converts the string into UTF-8, processes the escape sequence(s), and encodes the data.

When specifying binary data which cannot be represented as a string, use the following escape sequences.

String	Description
\xnn	Control code (set nn in hexadecimal)
\\	Back slash

type

Specifies the 2D symbol type.

Value	Description
Printer.SYMBOL_PDF417_STANDARD	Standard PDF417
Printer.SYMBOL_PDF417_TRUNCATED	Truncated PDF417
Printer.SYMBOL_QRCODE_MODEL_1	QR Code Model 1
Printer.SYMBOL_QRCODE_MODEL_2	QR Code Model 2
Printer.SYMBOL_QRCODE_MICRO	QR Code Micro
Printer.SYMBOL_MAXICODE_MODE_2	MaxiCode Mode 2
Printer.SYMBOL_MAXICODE_MODE_3	MaxiCode Mode 3
Printer.SYMBOL_MAXICODE_MODE_4	MaxiCode Mode 4
Printer.SYMBOL_MAXICODE_MODE_5	MaxiCode Mode 5
Printer.SYMBOL_MAXICODE_MODE_6	MaxiCode Mode 6
Printer.SYMBOL_GS1_DATABAR_STACKED	GS1 DataBar Stacked
Printer.SYMBOL_GS1_DATABAR_STACKED_OMNIDIRECTIONAL	GS1 DataBar Stacked Omnidirectional
Printer.SYMBOL_GS1_DATABAR_EXPANDED_STACKED	GS1 DataBar Expanded Stacked
Printer.SYMBOL_AZTECCODE_FULLRANGE	Aztec Code Full-Range mode

Value	Description
Printer.SYMBOL_AZTECCODE_COMPACT	Aztec Code Compact mode
Printer.SYMBOL_DATAMATRIX_SQUARE	DataMatrix Square
Printer.SYMBOL_DATAMATRIX_RECTANGLE_8	DataMatrix Rectangle, 8 lines
Printer.SYMBOL_DATAMATRIX_RECTANGLE_12	DataMatrix Rectangle, 12 lines
Printer.SYMBOL_DATAMATRIX_RECTANGLE_16	DataMatrix Rectangle, 16 lines

level

Specifies the error correction level.

Specify a value in accordance with the 2D symbol type.

Specify "PARAM_DEFAULT" for MaxiCode, 2D GS1 DataBar, and DataMatrix.

PDF417

Value	Description
Printer.LEVEL_0	Error correction level 0
Printer.LEVEL_1	Error correction level 1
Printer.LEVEL_2	Error correction level 2
Printer.LEVEL_3	Error correction level 3
Printer.LEVEL_4	Error correction level 4
Printer.LEVEL_5	Error correction level 5
Printer.LEVEL_6	Error correction level 6
Printer.LEVEL_7	Error correction level 7
Printer.LEVEL_8	Error correction level 8
Printer.PARAM_DEFAULT	Specifies the default value (error correction level 1).
Printer.PARAM_UNSPECIFIED	<Obsolete> Not specify.

QR Code

Value	Description
Printer.LEVEL_L	Error correction level L
Printer.LEVEL_M	Error correction level M
Printer.LEVEL_Q	Error correction level Q
Printer.LEVEL_H	Error correction level H
Printer.PARAM_DEFAULT	Specifies the default value (error correction level M).
Printer.PARAM_UNSPECIFIED	<Obsolete> Not specify.

Aztec Code

Value	Description
Integer from 5 to 95	Error correction level (in percents)
Printer.PARAM_DEFAULT	Specifies the default value (error correction level 23).
Printer.PARAM_UNSPECIFIED	<Obsolete> Not specify.

width

Specifies the module width.

An integer from 1 to 255 can be specified.

When "Printer.PARAM_UNSPECIFIED" is specified, the current setting is retained.

The range differs depending on the 2D symbol type.

2D symbol type	Valid value	Default value
PDF417	2 to 8	3
QR Code	3 to 16	3
MaxiCode	1 to 255 (Ignored)	
2D GS1 DataBar	2 to 8	2
Aztec Code	2 to 16	3
DataMatrix	2 to 16	3

height

Specifies the module height.

An integer from 1 to 255 can be specified.

When "Printer.PARAM_UNSPECIFIED" is specified, the current setting is retained.

The range differs depending on the 2D symbol type.

2D symbol type	Valid value	Default value
PDF417	2 to 8 (Scaling factor for width)	3
QR Code	1 to 255 (Ignored)	
MaxiCode		
2D GS1 DataBar		
Aztec Code		
DataMatrix		

size

Specifies the maximum size of the 2D symbol.

An integer from 0 to 65535 can be specified.

When "Printer.PARAM_UNSPECIFIED" is specified, the current setting is retained.

The range differs depending on the 2D symbol type.

2D symbol type		Default value	Description
PDF417		0 (auto)	Specifies the number of code words per stage.
QR Code		0 to 65535 (Ignored)	
MaxiCode		0 to 65535 (Ignored)	
2D GS1 DataBar	Expanded Stacked	0 (auto)	Specifies the maximum width of the 2D symbol (106 or more).
	Other	0 to 65535 (Ignored)	
Aztec Code		0 to 65535 (Ignored)	
DataMatrix		0 to 65535 (Ignored)	

Exception

When the process fails, Epos2Exception with one of the following error status occurs.

Error status	Description
ERR_PARAM	An invalid parameter was passed.
ERR_MEMORY	Memory necessary for processing could not be allocated.
ERR_FAILURE	An unknown error occurred.

Supplementary explanation

- Use this API at the "beginning of a line."
- When the 2D symbol data specified in data does not conform to the 2D symbol type specified in type, an error will not be returned as an exception and the 2D symbol will not be printed.
- During ESC/POS control, specifying values outside the valid ranges for the width and height parameters results in default value printing.
- During ePOS-Device XML control, specifying values outside the valid ranges for the width and height parameters causes [sendData](#) to generate an exception with ERR_FAILURE.

addHLine

Adds a horizontal ruled line print command to the command buffer.

Draws a horizontal ruled line.

Syntax

```
public void addHLine(int x1, int x2, int lineStyle) throws Epos2Exception
```

Parameter

x1

Specifies the start position to draw a horizontal ruled line (in dots).

Value	Description
Integer from 0 to 65535	Start position to draw a horizontal ruled line (in dots)

x2

Specifies the end position to draw a horizontal ruled line (in dots).

Value	Description
Integer from 0 to 65535	End position to draw a horizontal ruled line (in dots)

lineStyle

Specifies the ruled line type.

Value	Description
Printer.LINE_THIN	Solid line: Fine
Printer.LINE_MEDIUM	Solid line: Middle
Printer.LINE_THICK	Solid line: Thick
Printer.LINE_THIN_DOUBLE	Double line: Fine
Printer.LINE_MEDIUM_DOUBLE	Double line: Middle
Printer.LINE_THICK_DOUBLE	Double line: Thick
Printer.PARAM_DEFAULT	Specifies the default (Solid line: Fine).

Exception

When the process fails, Epos2Exception with one of the following error status occurs.

Error status	Description
ERR_PARAM	An invalid parameter was passed.
ERR_MEMORY	Memory necessary for processing could not be allocated.
ERR_FAILURE	An unknown error occurred.

Supplementary explanation

- ❑ This API cannot be used in the page mode.
- ❑ Use [addPageLine](#) to draw a horizontal ruled line in the page mode.

addVLineBegin

Adds a command to start drawing a vertical ruled line to the command buffer.
Starts drawing a vertical line.

Syntax

```
public void addVLineBegin(int x, int lineStyle, int[] lineId)
throws Epos2Exception
```

Parameter

x

Specifies the start position to draw a vertical ruled line (in dots).

Value	Description
Integer from 0 to 65535	Start position to draw a vertical ruled line (in dots)

lineStyle

Specifies the ruled line type.

Value	Description
Printer.LINE_THIN	Solid line: Fine
Printer.LINE_MEDIUM	Solid line: Middle
Printer.LINE_THICK	Solid line: Thick
Printer.LINE_THIN_DOUBLE	Double line: Fine
Printer.LINE_MEDIUM_DOUBLE	Double line: Middle
Printer.LINE_THICK_DOUBLE	Double line: Thick
Printer.PARAM_DEFAULT	Specifies the default (Solid line: Fine).

lineId

Returns the ID of the ruled line printed by this API.

Exception

When the process fails, Epos2Exception with one of the following error status occurs.

Error status	Description
ERR_PARAM	An invalid parameter was passed.
ERR_MEMORY	Memory necessary for processing could not be allocated.
ERR_FAILURE	An unknown error occurred.

Supplementary explanation

- ❑ This API cannot be used in the page mode.

- ❑ Use [addPageLine](#) to draw a vertical ruled line in the page mode.
- ❑ Drawing of the vertical ruled line continues until stopped by the [addVLineEnd](#) API.
- ❑ Use this API with the [addVLineEnd](#) API.

addVLineEnd

Adds a command to stop drawing a vertical ruled line to the command buffer.
Ends drawing a vertical line.

Syntax

```
public void addVLineEnd(int lineId) throws Epos2Exception
```

Parameter

lineId

Specifies the line ID acquired by [addVLineBegin](#).

Exception

When the process fails, Epos2Exception with one of the following error status occurs.

Error status	Description
ERR_PARAM	An invalid parameter was passed.
ERR_MEMORY	Memory necessary for processing could not be allocated.
ERR_FAILURE	An unknown error occurred.

Supplementary explanation

- This API cannot be used in the page mode.
- Use [addPageLine](#) to draw a vertical ruled line in the page mode.
- This API draws a vertical ruled line until stopped by [addVLineEnd](#).
- Use this API with the [addVLineBegin](#) API.

addPageBegin

Adds a page mode start command to the command buffer.
Starts processing in the page mode.

Syntax

```
public void addPageBegin() throws Epos2Exception
```

Exception

When the process fails, Epos2Exception with one of the following error status occurs.

Error status	Description
ERR_MEMORY	Memory necessary for processing could not be allocated.
ERR_FAILURE	An unknown error occurred.

Supplementary explanation

- ❑ The page mode does not support multi-gradation printing.
- ❑ Use this API with the [addPageEnd](#) API.

addPageEnd

Adds a page mode end command to the command buffer.
Ends processing in the page mode.

Syntax

```
public void addPageEnd() throws Epos2Exception
```

Exception

When the process fails, Epos2Exception with one of the following error status occurs.

Error status	Description
ERR_MEMORY	Memory necessary for processing could not be allocated.
ERR_FAILURE	An unknown error occurred.

Supplementary explanation

- ❑ The page mode does not support multi-gradation printing.
- ❑ Use this API with the [addPageBegin](#) API.

addPageArea

Adds page mode print area setting to the command buffer.

Specifies the page mode print area (coordinates). Following this API, call an API to specify print data such as the [addText](#) API.

Syntax

```
public void addPageArea(int x, int y, int width, int height)
throws Epos2Exception
```

Parameter

x

Specifies the horizontal origin (in dots).

Value	Description
Integer from 0 to 65535	Horizontal origin (in dots)

"0" specifies the leftmost position of the printable area of the printer.

y

Specifies the vertical origin (in dots).

Value	Description
Integer from 0 to 65535	Vertical origin (in dots)

"0" specifies the position where paper is not fed.

width

Specifies the width of a print area (in dots).

Value	Description
Integer from 1 to 65535	Width of a print area (in dots)

height

Specifies the height of a print area (in dots).

Value	Description
Integer from 1 to 65535	Height of a print area (in dots)

Exception

When the process fails, Epos2Exception with one of the following error status occurs.

Error status	Description
ERR_PARAM	An invalid parameter was passed.
ERR_MEMORY	Memory necessary for processing could not be allocated.

Error status	Description
ERR_FAILURE	An unknown error occurred.

Supplementary explanation

- ❑ Define the print area in accordance with the contents to print. If the print data does not fit within the print area, the printed contents will be truncated.
- ❑ Use this API between the [addPageBegin](#) and [addPageEnd](#) APIs.
- ❑ Specify the width and height of the print area in accordance with the print direction setting. Otherwise the print data may be truncated. Set the print direction by [addPageDirection](#).
- ❑ This API does not work in the standard mode.

addPageDirection

Adds page mode print direction setting to the command buffer.
Specifies the print direction in the page mode.

Syntax

```
public void addPageDirection(int direction) throws
Epos2Exception
```

Parameter

direction

Specifies the print direction in the page mode.

Value	Description
Printer.DIRECTION_LEFT_TO_RIGHT (default)	Do not rotate data. (Data is printed rightward from the upper-left position.)
Printer.DIRECTION_BOTTOM_TO_TOP	Rotate data counterclockwise by 90 degrees. (Data is printed upward from the lower-left position.)
Printer.DIRECTION_RIGHT_TO_LEFT	Rotate data by 180 degrees. (Data is printed leftward from the lower-right position.)
Printer.DIRECTION_TOP_TO_BOTTOM	Rotate data clockwise by 90 degrees. (Data is printed downward from the upper-right position.)
Printer.PARAM_DEFAULT	Specifies the default value (no rotation).

Exception

When the process fails, Epos2Exception with one of the following error status occurs.

Error status	Description
ERR_PARAM	An invalid parameter was passed.
ERR_MEMORY	Memory necessary for processing could not be allocated.
ERR_FAILURE	An unknown error occurred.

Supplementary explanation

- This API does not work in the standard mode.
- Use this API between the [addPageBegin](#) and [addPageEnd](#) APIs.

addPagePosition

Adds print position setting within the print area in the page mode to the command buffer.

Specifies the print start position (coordinates) within the area specified by the [addPageArea](#) API.

Syntax

```
public void addPagePosition(int x, int y) throws
Epos2Exception
```

Parameter

x

Specifies the horizontal print position (in dots).

Value	Description
Integer from 0 to 65535	Horizontal print position (in dots)
Printer.PARAM_UNSPECIFIED	<Obsolete> Not specify.

y

Specifies the vertical print position (in dots).

Value	Description
Integer from 0 to 65535	Specify the horizontal print position in dots.
Printer.PARAM_UNSPECIFIED	<Obsolete> Not specify.

Exception

When the process fails, Epos2Exception with one of the following error status occurs.

Error status	Description
ERR_PARAM	An invalid parameter was passed.
ERR_MEMORY	Memory necessary for processing could not be allocated.
ERR_FAILURE	An unknown error occurred.

Supplementary explanation

- This API does not work in the standard mode.
- Use this API between the [addPageBegin](#) and [addPageEnd](#) APIs.
- Specify the print start position (coordinates) in accordance with the contents to print. See below.

Print data	Specification method
When printing a text string	Specify the leftmost position of the baseline for the first character. This can be omitted when printing data with the standard size in left justification. When printing a double-height character, set y to 42 or larger.
When printing a barcode	Specify the lower-left position of the symbol. Specify the height of the barcode in y.
When printing graphics/logo	Specify the lower-left position of the graphic data. Specify the height of the graphic data in y.
When printing a 2D symbol	Specify the upper-left position of the symbol. This can be omitted when printing from the upper-left position.

❑ If all the parameters are set to "Printer.PARAM_UNSPECIFIED," ERR_PARAM will be returned.

addPageLine

Adds a page mode line draw command to the command buffer.

Draws a line in the page mode.

Syntax

```
public void addPageLine(int x1, int y1, int x2, int y2, int
lineStyle) throws Epos2Exception
```

Parameter

x1

Specifies the horizontal position to start drawing (in dots).

Value	Description
Integer from 0 to 65535	Horizontal position to start drawing (in dots)

y1

Specifies the vertical position to start drawing (in dots).

Value	Description
Integer from 0 to 65535	Vertical position to start drawing (in dots)

x2

Specifies the horizontal position to end drawing (in dots).

Value	Description
Integer from 0 to 65535	Horizontal position to end drawing (in dots)

y2

Specifies the vertical position to end drawing (in dots).

Value	Description
Integer from 0 to 65535	Vertical position to end drawing (in dots)

lineStyle

Specifies the ruled line type.

Value	Description
Printer.LINE_THIN	Solid line: Fine
Printer.LINE_MEDIUM	Solid line: Middle
Printer.LINE_THICK	Solid line: Thick
Printer.LINE_THIN_DOUBLE	Double line: Fine
Printer.LINE_MEDIUM_DOUBLE	Double line: Middle

Value	Description
Printer.LINE_THICK_DOUBLE	Double line: Thick
Printer.PARAM_DEFAULT	Specifies the default (Solid line: Fine).

Exception

When the process fails, Epos2Exception with one of the following error status occurs.

Error status	Description
ERR_PARAM	An invalid parameter was passed.
ERR_MEMORY	Memory necessary for processing could not be allocated.
ERR_FAILURE	An unknown error occurred.

Supplementary explanation

- This API does not work in the standard mode.
- A diagonal line cannot be drawn.
- Use this API between the [addPageBegin](#) and [addPageEnd](#) APIs.

addPageRectangle

Adds a page mode rectangle draw command to the command buffer.

Draws a rectangle in the page mode.

Syntax

```
public void addPageRectangle(int x1, int y1, int x2, int y2, int
lineStyle) throws Epos2Exception
```

Parameter

x1

Specifies the horizontal position to start drawing (in dots).

Value	Description
Integer from 0 to 65535	Horizontal position to start drawing (in dots)

y1

Specifies the vertical position to start drawing (in dots).

Value	Description
Integer from 0 to 65535	Vertical position to start drawing (in dots)

x2

Specifies the horizontal position to end drawing (in dots).

Value	Description
Integer from 0 to 65535	Horizontal position to end drawing (in dots)

y2

Specifies the vertical position to end drawing (in dots).

Value	Description
Integer from 0 to 65535	Vertical position to end drawing (in dots)

lineStyle

Specifies the line type.

Value	Description
Printer.LINE_THIN	Solid line: Fine
Printer.LINE_MEDIUM	Solid line: Middle
Printer.LINE_THICK	Solid line: Thick
Printer.LINE_THIN_DOUBLE	Double line: Fine
Printer.LINE_MEDIUM_DOUBLE	Double line: Middle

Value	Description
Printer.LINE_THICK_DOUBLE	Double line: Thick
Printer.PARAM_DEFAULT	Specifies the default (Solid line: Fine).

Exception

When the process fails, Epos2Exception with one of the following error status occurs.

Error status	Description
ERR_PARAM	An invalid parameter was passed.
ERR_MEMORY	Memory necessary for processing could not be allocated.
ERR_FAILURE	An unknown error occurred.

Supplementary explanation

- This API does not work in the standard mode.
- Use this API between the [addPageBegin](#) and [addPageEnd](#) APIs.

addRotateBegin

Adds the start batch rotate print mode to the command buffer.

Syntax

```
public void addRotateBegin()throws Epos2Exception
```

Exception

When the process fails, Epos2Exception with one of the following error status occurs.

Error status	Description
ERR_MEMORY	Memory necessary for processing could not be allocated.
ERR_FAILURE	An unknown error occurred.

Supplementary explanation

- ❑ This API does not work in the page mode.
- ❑ Use the add APIs for batch rotate printing (Example: [addText](#)) by enclosing between this API and the [addRotateEnd](#) API.
- ❑ Do not use the following APIs between this API and the [addRotateEnd](#) API.
 - [endTransaction](#)
 - [addPageBegin](#)
 - [addPageEnd](#)
 - [addCut](#)
 - [addPulse](#)
 - [addSound](#)
 - [setPrinterSetting](#)
 - [ejectPaper](#)
- ❑ The data volume that the printer can process in a single batch rotate printing is as described below.
 - Strings: 80 lines
 - Graphics: 2400 dots
- ❑ When you are using the add APIs (Example: [addText](#)) in the batch rotate print mode, you must take care while using certain APIs.

API	Precautions
addTextSize	<ul style="list-style-type: none"> • If the longitudinal direction is set to triple angle or higher with addTextSize before this API, then this API and the succeeding APIs will become double-angled. • If the longitudinal direction is set to triple angle or higher with addTextSize after this API, then the specification in the longitudinal direction will be ignored and become single-angled.
addFeedUnit	The number of paper feed lines varies depending on the line spacing specified in addLineSpace . If the line spacing is specified as 30 in addLineSpace , paper feeding can be performed for 8 lines with the maximum value of addFeedUnit as 255.

API	Precautions
addImage	<ul style="list-style-type: none">• Graphics cannot be split and processed (printed). If 500-dot data B is sent to a location in the printer buffer where 2000-dot data A is accumulated, then data B will be accumulated in the printer buffer after data A has been printed.• The multi-gradation (16 scales) maximum size is up to 600 dots vertically. In the case of multi-gradation (16 scales), a data volume that is four times that of monochrome (2 scales) is required.• If the vertical size exceeds the data volume that can be processed in one go, printing will not be performed. Monochrome (2 scales) maximum value: 2400 dots Multi-gradation (16 scales) maximum value: 600 dots

addRotateEnd

Adds the end batch rotate print mode to the command buffer.

Syntax

```
public void addRotateEnd()throws Epos2Exception
```

Exception

When the process fails, Epos2Exception with one of the following error status occurs.

Error status	Description
ERR_MEMORY	Memory necessary for processing could not be allocated.
ERR_FAILURE	An unknown error occurred.

Supplementary explanation

- ❑ This API does not work in the page mode.
- ❑ Use the add APIs for batch rotate printing (Example: [addText](#)) by enclosing between this API and the [addRotateBegin](#) API.

addCut

Adds a sheet cut command to the command buffer.
Sets how to cut paper.

Syntax

```
public void addCut(int type) throws Epos2Exception
```

Parameter

type

Specifies how to cut paper.

Value	Description
Printer.CUT_FEED	Feed cut (cut the sheet after feeding paper).
Printer.CUT_NO_FEED	Cut without feed (cut the sheet without feeding paper).
Printer.CUT_RESERVE	Cut reservation (print the following texts and cut the sheet at the cutting position).
Printer.PARAM_DEFAULT	Specifies the default (feed cut (cut the sheet after feeding paper)).

Exception

When the process fails, Epos2Exception with one of the following error status occurs.

Error status	Description
ERR_PARAM	An invalid parameter was passed.
ERR_MEMORY	Memory necessary for processing could not be allocated.
ERR_FAILURE	An unknown error occurred.

Supplementary explanation

- ❑ This API cannot be used in the page mode.
- ❑ Use this API at the "beginning of a line." If this API is used elsewhere, it will be ignored.
- ❑ If print data is not specified after the cut reservation (Printer.CUT_RESERVE), the printer will execute the cut after feeding paper up to the position of the reserved cut.
- ❑ Depending on the printer, it may wait approximately 2 seconds for the print data after the cut reservation (Printer.CUT_RESERVE) before starting the paper feed operation.
- ❑ When using the cut reservation (Printer.CUT_RESERVE), set the length of one receipt to at least 20 mm.

addPulse

Adds a drawer kick command to the command buffer.
Sets the drawer kick.

Syntax

```
public void addPulse(int drawer, int time) throws
Epos2Exception
```

Parameter

drawer

Specifies the drawer kick connector.

Value	Description
Printer.DRAWER_2PIN	Drawer kick connector pin No.2
Printer.DRAWER_5PIN	Drawer kick connector pin No.5
Printer.PARAM_DEFAULT	Specifies the default (drawer kick connector pin No.2).

time

Specifies the on time of the drawer kick signal.

Value	Description
Printer.PULSE_100	100-msec signal
Printer.PULSE_200	200-msec signal
Printer.PULSE_300	300-msec signal
Printer.PULSE_400	400-msec signal
Printer.PULSE_500	500-msec signal
Printer.PARAM_DEFAULT	Specifies the default (100-msec signal).

Exception

When the process fails, Epos2Exception with one of the following error status occurs.

Error status	Description
ERR_PARAM	An invalid parameter was passed.
ERR_MEMORY	Memory necessary for processing could not be allocated.
ERR_FAILURE	An unknown error occurred.

Supplementary explanation

- ❑ This API cannot be used in the page mode.

- ❑ The drawer and optional external buzzer cannot be connected simultaneously.
- ❑ Do not open the drawer repeatedly for a short time. The drawer may be damaged due to too much load.
- ❑ For built-in buzzer equipped models of the following printers, sounding the buzzer is possible using the pulse output commands for drawer kick connectors.

For details on controlling the built-in buzzer, refer to the Technical Reference Guide of the printer.

- TM-T70
- TM-T70II
- TM-T82II
- TM-T82III
- TM-T83II
- TM-T88IV
- TM-T88V
- TM-T88VI
- TM-T82II-i
- TM-T83II-i
- TM-T88VI-iHUB
- TM-L90

addSound

Adds buzzer sound setting to the command buffer.

Sets the buzzer.

Syntax

```
public void addSound(int pattern, int repeat, int cycle) throws Epos2Exception
```

Parameter

pattern

Specifies the buzzer tone.

Value	Description
Printer.PATTERN_NONE	Stop (Mobile models)
Printer.PATTERN_NONE	Stop. However, the buzzer already sounding does not stop. (Except for Mobile models)
Printer.PATTERN_A	Pattern A (optional external buzzer)
Printer.PATTERN_B	Pattern B (optional external buzzer)
Printer.PATTERN_C	Pattern C (optional external buzzer)
Printer.PATTERN_D	Pattern D (optional external buzzer)
Printer.PATTERN_E	Pattern E (optional external buzzer)
Printer.PATTERN_ERROR	Error sound pattern (optional external buzzer)
Printer.PATTERN_PAPER_EMPTY	Paper empty sound pattern (optional external buzzer)
Printer.PATTERN_1	Pattern 1 (built-in buzzer)
Printer.PATTERN_2	Pattern 2 (built-in buzzer)
Printer.PATTERN_3	Pattern 3 (built-in buzzer)
Printer.PATTERN_4	Pattern 4 (built-in buzzer)
Printer.PATTERN_5	Pattern 5 (built-in buzzer)
Printer.PATTERN_6	Pattern 6 (built-in buzzer)
Printer.PATTERN_7	Pattern 7 (built-in buzzer)
Printer.PATTERN_8	Pattern 8 (built-in buzzer)
Printer.PATTERN_9	Pattern 9 (built-in buzzer)
Printer.PATTERN_10	Pattern 10 (built-in buzzer)
Printer.PARAM_DEFAULT	Specifies the default (Pattern A).

repeat

Specifies the repeat count.

Value	Description
0	Unlimited
1 to 255	1 to 255 times
Printer.PARAM_DEFAULT	Specifies the default (once).

cycle

Specifies the buzzer sound interval (in milliseconds).

Value	Description
1000 to 25500	1000 to 25500 milliseconds
Printer.PARAM_DEFAULT	Specifies the default (1000 milliseconds).

Effective for Patterns 1 to 10 only.

Exception

When the process fails, Epos2Exception with one of the following error status occurs.

Error status	Description
ERR_PARAM	An invalid parameter was passed.
ERR_MEMORY	Memory necessary for processing could not be allocated.
ERR_FAILURE	An unknown error occurred.

Supplementary explanation

- This API cannot be used in the page mode.
- The drawer and optional external buzzer cannot be connected simultaneously.
- This API cannot be used if the printer is not equipped with a buzzer.
- The timing to receive the callback of sendData API varies by printer.
 - Mobile models: after the [sendData](#) API is executed.
 - Other than Mobile models: after the buzzer sounding is finished.
- For built-in buzzer equipped models of the following printers, sounding the buzzer is possible using [addPulse](#).
 - TM-T70
 - TM-T70II
 - TM-T82II
 - TM-T82III
 - TM-T83II
 - TM-T88IV
 - TM-T88V
 - TM-T88VI
 - TM-T82II-i
 - TM-T83II-i

- TM-T88VI-iHUB
- TM-L90

addFeedPosition

Adds a label sheet/black mark sheet feed command to the command buffer.

Syntax

```
public void addFeedPosition(int position) throws
Epos2Exception
```

Parameter

position

Specifies the paper feed position.

Value	Description
Printer.FEED_PEELING	Feed the sheet to the peeling position.
Printer.FEED_CUTTING	Feed the sheet to the cut position.
Printer.FEED_CURRENT_TOF	Feed the sheet to the top of the current label.
Printer.FEED_NEXT_TOF	Feed the sheet to the top of the next label.

Exception

When the process fails, Epos2Exception with one of the following error status occurs.

Error status	Description
ERR_PARAM	An invalid parameter was passed.
ERR_MEMORY	Memory necessary for processing could not be allocated.
ERR_FAILURE	An unknown error occurred.

Supplementary explanation

- The label sheet/black mark sheet can be controlled in the standard mode.
- This API cannot be used in the page mode.

addLayout

Adds layout setting of the label sheet/black mark sheet to the command buffer.

Syntax

```
public void addLayout(int type, int width, int height, int
marginTop, int marginBottom, int offsetCut, int offsetLabel)
throws Epos2Exception
```

Parameter

type

Specifies the paper type.

Value	Description
Printer.LAYOUT_RECEIPT	Receipt (without black mark)
Printer.LAYOUT_RECEIPT_BM	Receipt (with black mark)
Printer.LAYOUT_LABEL	Label sheet (without black mark)
Printer.LAYOUT_LABEL_BM	Label sheet (with black mark)

width

Specifies the paper width (in 0.1 mm units).

Value		Description
TM Printer Models	POS Terminal Model	
Integer from 1 to 10000	Integer from 290 to 600	Paper width (in 0.1 mm units)

height

Specifies the distance from the print reference mark to the next print reference mark (in 0.1mm units).

Sheet type	Value		Description
	TM Printer Models	POS Terminal Model	
Receipt (without black mark)	0	0	No distance specified (auto)
Receipt (with black mark)	0 to 10000	0 to 1550	Distance between the top edges of two consecutive black marks.
Label sheet (without black mark)			Distance between the top edges of two consecutive labels
Label sheet (with black mark)			Distance between the bottom edges of two consecutive black marks.

marginTop

Specifies the distance from the print reference mark to the top of the sheet (in 0.1mm units).

Sheet type	Value		Description
	TM Printer Models	POS Terminal Model	
Receipt (without black mark)	0	0	No distance specified (auto)
Receipt (with black mark)	-9999 to 10000	-150 to 1500	Distance from the top edge of the black mark to the top of the sheet
Label sheet (without black mark)	0 to 10000	0 to 1500	Distance from the top edge of the label to the top of the sheet
Label sheet (with black mark)	-9999 to 10000	-15 to 1500	Distance from the bottom edge of the black mark to the top of the sheet

marginBottom

Specifies the distance from the eject reference mark to the bottom edge of the printable area (in 0.1mm units).

Sheet type	Value		Description
	TM Printer Models	POS Terminal Model	
Receipt (without black mark)	0	0	No distance specified (auto)
Receipt (with black mark)	0	0	No distance specified (auto)
Label sheet (without black mark)	-9999 to 0	-15 to 0	Distance from the bottom edge of the label (A positive value represents the paper feed direction.)
Label sheet (with black mark)	-9999 to 10000	-15 to 15	Distance from the top of the black mark (A positive value represents the paper feed direction.)

offsetCut

Specifies the distance from the eject reference mark to the cut position (in 0.1mm units).

Sheet type	Value		Description
	TM Printer Models	POS Terminal Model	
Receipt (without black mark)	0	0	No distance specified (auto)
Receipt (with black mark)	-9999 to 10000	-290 to 50	Distance from the top edge of the black mark to the cut position
Label sheet (without black mark)	0 to 10000	0 to 50	Distance from the bottom edge of the label to the cut position
Label sheet (with black mark)	0 to 10000	0 to 50	Distance from the top edge of the black mark to the cut position

offsetLabel

Specifies the distance from the eject reference mark to the bottom edge of the label (in 0.1mm units).

Sheet type	Value		Description
	TM Printer Models	POS Terminal Model	
Receipt (without black mark)	0	0	No distance specified (auto)
Receipt (with black mark)	0	0	No distance specified (auto)
Label sheet (without black mark)	0	0	No distance specified (auto)
Label sheet (with black mark)	0 to 10000	0 to 15	Distance from the top edge of the black mark to the bottom edge of a label

Exception

When the process fails, Epos2Exception with one of the following error status occurs.

Error status	Description
ERR_PARAM	An invalid parameter was passed.
ERR_MEMORY	Memory necessary for processing could not be allocated.
ERR_FAILURE	An unknown error occurred.

Supplementary explanation

- ❑ This API does not work in the page mode.
- ❑ Available setting values vary by TM printer model. For more details, see the FS (L<Function 33> command).
<https://reference.epson-biz.com/pos/reference/>
- ❑ The available parameter values for each type of paper are listed below.
The following table shows available values for TM printer models, and shows those for POS terminal models in parentheses.

Parameter	Receipt (without black mark)	Label sheet (without black mark)	Label sheet (with black mark)	Receipt (with black mark)	Symbol in diagram
width	1 to 10000 (290 to 600)				f
height	0 (0)	0 to 10000 (0 to 1550)			a
marginTop	0 (0)	0 to 10000 (0 to 1500)	-9999 to 10000 (-15 to 1500)	-9999 to 10000 (-150 to 1500)	b
marginBottom	0 (0)	-9999 to 0 (-15 to 0)	-9999 to 10000 (-15 to 15)	0 (0)	e
offsetCut	0 (0)	0 to 10000 (0 to 50)		-9999 to 10000 (-290 to 50)	c
offsetLabel	0 (0)			0 to 10000 (0 to 15)	d

Receipt

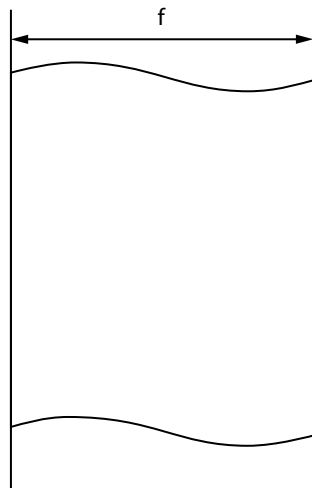

<with Black Mark>

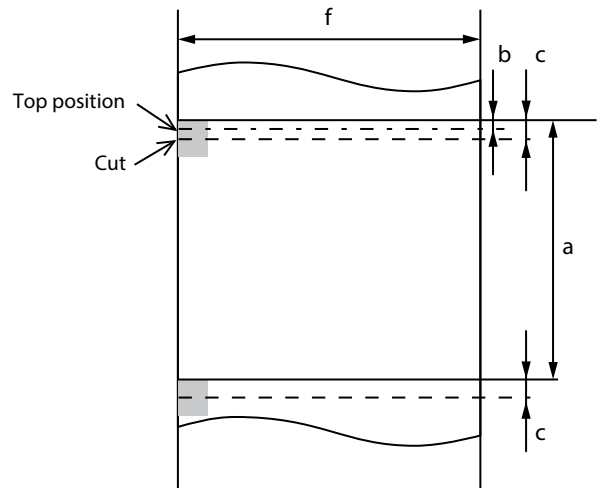

Label

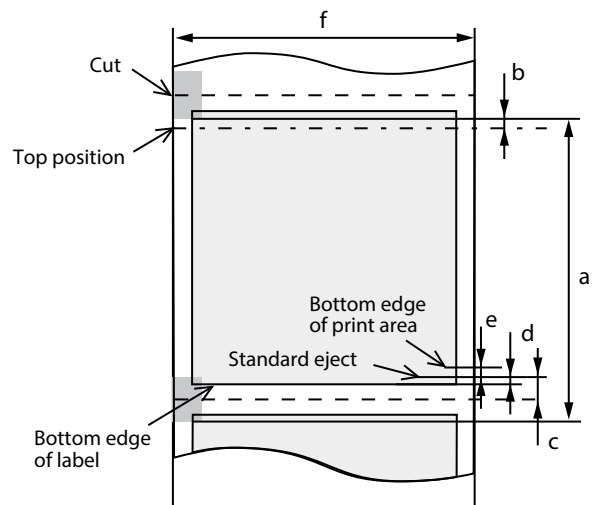
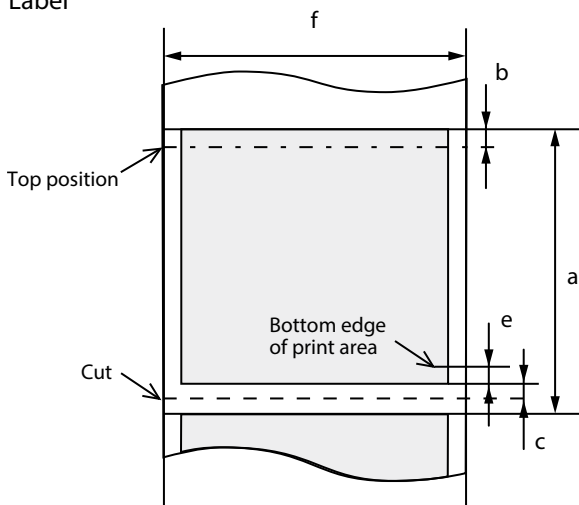

addCommand

Adds a command to the command buffer.
Sends the ESC/POS command.

Syntax

```
public void addCommand(byte[] data) throws Epos2Exception
```

Parameter

data

Specifies the ESC/POS command.

Specifies the binary data.

Exception

When the process fails, Epos2Exception with one of the following error status occurs.

Error status	Description
ERR_PARAM	An invalid parameter was passed.
ERR_MEMORY	Memory necessary for processing could not be allocated.
ERR_FAILURE	An unknown error occurred.

Supplementary explanation

- ❑ Refer to the following URL for details of the ESC/POS command.
https://reference.epson-biz.com/modules/ref_escpos/
- ❑ Epson ePOS SDK does not check the commands sent using this API.
If the commands interfere with Epson ePOS SDK operations, other APIs may work wrongly or status values may become invalid.
This API should be used with a full understanding of ESC/POS commands and the receipt printer specifications.

getMaintenanceCounter

Acquires the value of the printer's maintenance counter.

The value acquired by this API is notified to the listener registration method specified in the listener parameter.

Syntax

```
public void getMaintenanceCounter(int timeout, int type,
MaintenanceCounterListener listener) throws Epos2Exception
```

Parameter

timeout

Specifies the timeout period before completion of printing in milliseconds.

Value	Description
Integer from 5000 to 600000	Timeout period (in milliseconds)
Printer.PARAM_DEFAULT	Specifies the default value (10000).

type

Specifies the type of maintenance counter to be acquired.

Value	Description
Printer.MaintenanceCounter.PaperFeed	Number of paper feed lines
Printer.MaintenanceCounter.AutoCutter	Number of times auto cutter is operated

listener

Registers the listener registration method that returns the processing result of this API.

```
- (void) onGetMaintenanceCounter(int code, int type, int value);
```

code

The processing result is stored.

Error status	Description
CODE_SUCCESS	Processed successfully.
CODE_ERR_AUTORECOVER	Automatic recovery error occurred.
CODE_ERR_COVER_OPEN	Cover open error occurred.
CODE_ERR_CUTTER	Auto cutter error occurred.
CODE_ERR_MECHANICAL	Mechanical error occurred.
CODE_ERR_EMPTY	No paper is left in the roll paper end detector.
CODE_ERR_PARAM	An invalid parameter was passed.

Error status	Description
CODE_ERR_MEMORY	Memory necessary for processing could not be allocated.
CODE_ERR_TIMEOUT	Failed to communicate with the devices within the specified time.
CODE_ERR_PROCESSING	Could not run the process.
CODE_ERR_ILLEGAL	This API was called while no communication had been started.
CODE_ERR_FAILURE	An unknown error occurred.

Exception

When the process fails, Epos2Exception with one of the following error status occurs.

Error status	Description
ERR_PARAM	An invalid parameter was passed.
ERR_FAILURE	An unknown error occurred.

Supplementary explanation

- ❑ This API cannot be used simultaneously with other APIs.
After executing this API, do not execute any other API until the callback is returned.
- ❑ Do not turn off the power supply to the printer while executing this API.
- ❑ This API can be used in the system configuration of the TM printer model and customer display model.
With the system configuration of the TM Printer + DM-D30 + barcode scanner model, this API can be used when connecting via *Bluetooth* or USB.
- ❑ This API cannot be used with SSL/TLS communication.

resetMaintenanceCounter

Resets the value of the printer's maintenance counter.

The value acquired by this API is notified to the listener registration method specified in the listener parameter.

Syntax

```
public void resetMaintenanceCounter(int timeout, int type,
MaintenanceCounterListener listener) throws Epos2Exception
```

Parameter

timeout

Specifies the timeout period before completion of printing in milliseconds.

Value	Description
Integer from 5000 to 600000	Timeout period (in milliseconds)
Printer.PARAM_DEFAULT	Specifies the default value (10000).

type

Specifies the type of maintenance counter to be reset.

Value	Description
Printer.MaintenanceCounter.PaperFeed	Number of paper feed lines
Printer.MaintenanceCounter.AutoCutter	Number of times auto cutter is operated

listener

Registers the listener registration method that returns the processing result of this API.

- (void) onResetMaintenanceCounter(int code, int type);

code

The processing result is stored.

Error status	Description
CODE_SUCCESS	Processed successfully.
CODE_ERR_AUTORECOVER	Automatic recovery error occurred.
CODE_ERR_COVER_OPEN	Cover open error occurred.
CODE_ERR_CUTTER	Auto cutter error occurred.
CODE_ERR_MECHANICAL	Mechanical error occurred.
CODE_ERR_EMPTY	No paper is left in the roll paper end detector.
CODE_ERR_PARAM	An invalid parameter was passed.
CODE_ERR_MEMORY	Memory necessary for processing could not be allocated.

Error status	Description
CODE_ERR_TIMEOUT	Failed to communicate with the devices within the specified time.
CODE_ERR_PROCESSING	Could not run the process.
CODE_ERR_ILLEGAL	This API was called while no communication had been started.
CODE_ERR_FAILURE	An unknown error occurred.

type

The type of maintenance counter reset is stored.

Exception

When the process fails, Epos2Exception with one of the following error status occurs.

Error status	Description
ERR_PARAM	An invalid parameter was passed.
ERR_FAILURE	An unknown error occurred.

Supplementary explanation

- This API cannot be used simultaneously with other APIs.
After executing this API, do not execute any other API until the callback is returned.
- Do not turn off the power supply to the printer while executing this API.
- Do not execute this API more than 10 times per day. If executed more than this number of times, the printer may become unable to operate.
- This API can be used in the system configuration of the TM printer model and customer display model.
With the system configuration of the TM Printer + DM-D30 + barcode scanner model, this API can be used when connecting via *Bluetooth* or USB.
- This API cannot be used with SSL/TLS communication.

getPrinterSetting

Acquires the set value of the printer setting.

The value acquired by this API is notified to the listener registration method specified in the listener parameter.

Syntax

```
public void getPrinterSetting(int timeout, int type,
    PrinterSettingListener listener) throws Epos2Exception
```

Parameter

timeout

Specifies the timeout period before completion of printing in milliseconds.

Value	Description
Integer from 5000 to 600000	Timeout period (in milliseconds)
Printer.PARAM_DEFAULT	Specifies the default value (10000).

type

Specifies the printer setting item to be acquired.

Value	Description
Printer.Setting.PaperWidth	Paper width
Printer.Setting.PrintDensity	Print density
Printer.Setting.PrintSpeed	Print speed

listener

Registers the listener registration method that returns the processing result of this API.

- (void) onGetPrinterSetting(int code, int type, int value);

❑ code

The processing result is stored.

Error status	Description
CODE_SUCCESS	Processed successfully.
CODE_ERR_AUTORECOVER	Automatic recovery error occurred.
CODE_ERR_COVER_OPEN	Cover open error occurred.
CODE_ERR_CUTTER	Auto cutter error occurred.
CODE_ERR_MECHANICAL	Mechanical error occurred.
CODE_ERR_EMPTY	No paper is left in the roll paper end detector.
CODE_ERR_PARAM	An invalid parameter was passed.

Error status	Description
CODE_ERR_MEMORY	Memory necessary for processing could not be allocated.
CODE_ERR_TIMEOUT	Failed to communicate with the devices within the specified time.
CODE_ERR_PROCESSING	Could not run the process.
CODE_ERR_ILLEGAL	This API was called while no communication had been started.
CODE_ERR_FAILURE	An unknown error occurred.

❑ type

The acquired printer setting item is stored.

Value	Description
Printer.Setting.PaperWidth	Paper width
Printer.Setting.PrintDensity	Print density
Printer.Setting.PrintSpeed	Print speed

❑ value

The acquired set value of the printer setting is stored.

Value	Description
Printer.Setting.PaperWidth58_0	Paper width 58 mm
Printer.Setting.PaperWidth60_0	Paper width 60 mm
Printer.Setting.PaperWidth80_0	Paper width 80 mm
Printer.Setting.PrintDensityDIP	Print density DIP switch setting
Printer.Setting.PrintDensity70	Print density 70%
Printer.Setting.PrintDensity75	Print density 75%
Printer.Setting.PrintDensity80	Print density 80%
Printer.Setting.PrintDensity85	Print density 85%
Printer.Setting.PrintDensity90	Print density 90%
Printer.Setting.PrintDensity95	Print density 95%
Printer.Setting.PrintDensity100	Print density 100%
Printer.Setting.PrintDensity105	Print density 105%
Printer.Setting.PrintDensity110	Print density 110%
Printer.Setting.PrintDensity115	Print density 115%
Printer.Setting.PrintDensity120	Print density 120%
Printer.Setting.PrintDensity125	Print density 125%

Value	Description
Printer.Setting.PrintDensity130	Print density 130%
Printer.Setting.PrintSpeed1	Print speed level 1
Printer.Setting.PrintSpeed2	Print speed level 2
Printer.Setting.PrintSpeed3	Print speed level 3
Printer.Setting.PrintSpeed4	Print speed level 4
Printer.Setting.PrintSpeed5	Print speed level 5
Printer.Setting.PrintSpeed6	Print speed level 6
Printer.Setting.PrintSpeed7	Print speed level 7
Printer.Setting.PrintSpeed8	Print speed level 8
Printer.Setting.PrintSpeed9	Print speed level 9
Printer.Setting.PrintSpeed10	Print speed level 10
Printer.Setting.PrintSpeed11	Print speed level 11
Printer.Setting.PrintSpeed12	Print speed level 12
Printer.Setting.PrintSpeed13	Print speed level 13
Printer.Setting.PrintSpeed14	Print speed level 14

Exception

When the process fails, Epos2Exception with one of the following error status occurs.

Error status	Description
ERR_PARAM	An invalid parameter was passed.
ERR_FAILURE	An unknown error occurred.

Supplementary explanation

- ❑ This API cannot be used simultaneously with other APIs.
After executing this API, do not execute any other API until the callback is returned.
- ❑ Do not turn off the power supply to the printer while executing this API.
- ❑ This API can be used in the system configuration of the TM printer model and customer display model.
With the system configuration of the TM Printer + DM-D30 + barcode scanner model, this API can be used when connecting via *Bluetooth* or *USB*.
- ❑ This API cannot be used with *SSL/TLS* communication.

setPrinterSetting

Changes the set value of the printer setting.

The value acquired by this API is notified to the listener registration method specified in the listener parameter.

Syntax

```
public void setPrinterSetting(int timeout,
    java.util.Map<java.lang.Integer, java.lang.Integer> list,
    PrinterSettingListener listener) throws Epos2Exception
```

Parameter

timeout

Specifies the timeout period before completion of printing in milliseconds.

Value	Description
Integer from 5000 to 600000	Timeout period (in milliseconds)
Printer.PARAM_DEFAULT	Specifies the default value (10000).

list

Specifies the list combining the changed printer setting item (type) and the set value (value).

type

Specifies the printer setting item to be changed.

Value	Description
Printer.Setting.PaperWidth	Paper width
Printer.Setting.PrintDensity	Print density
Printer.Setting.PrintSpeed	Print speed

value

Specifies the set value of the printer setting to be changed.

Value	Description
Printer.Setting.PaperWidth58_0	Paper width 58 mm
Printer.Setting.PaperWidth60_0	Paper width 60 mm
Printer.Setting.PaperWidth80_0	Paper width 80 mm
Printer.Setting.PrintDensityDIP	Print density DIP switch setting
Printer.Setting.PrintDensity70	Print density 70%
Printer.Setting.PrintDensity75	Print density 75%
Printer.Setting.PrintDensity80	Print density 80%
Printer.Setting.PrintDensity85	Print density 85%

Value	Description
Printer.Setting.PrintDensity90	Print density 90%
Printer.Setting.PrintDensity95	Print density 95%
Printer.Setting.PrintDensity100	Print density 100%
Printer.Setting.PrintDensity105	Print density 105%
Printer.Setting.PrintDensity110	Print density 110%
Printer.Setting.PrintDensity115	Print density 115%
Printer.Setting.PrintDensity120	Print density 120%
Printer.Setting.PrintDensity125	Print density 125%
Printer.Setting.PrintDensity130	Print density 130%
Printer.Setting.PrintSpeed1	Print speed level 1
Printer.Setting.PrintSpeed2	Print speed level 2
Printer.Setting.PrintSpeed3	Print speed level 3
Printer.Setting.PrintSpeed4	Print speed level 4
Printer.Setting.PrintSpeed5	Print speed level 5
Printer.Setting.PrintSpeed6	Print speed level 6
Printer.Setting.PrintSpeed7	Print speed level 7
Printer.Setting.PrintSpeed8	Print speed level 8
Printer.Setting.PrintSpeed9	Print speed level 9
Printer.Setting.PrintSpeed10	Print speed level 10
Printer.Setting.PrintSpeed11	Print speed level 11
Printer.Setting.PrintSpeed12	Print speed level 12
Printer.Setting.PrintSpeed13	Print speed level 13
Printer.Setting.PrintSpeed14	Print speed level 14

listener

Registers the listener registration method that returns the processing result of this API.

- (void) onSetPrinterSetting(int code);

code

The processing result is stored.

Error status	Description
CODE_SUCCESS	Processed successfully.
CODE_ERR_AUTORECOVER	Automatic recovery error occurred.

Error status	Description
CODE_ERR_COVER_OPEN	Cover open error occurred.
CODE_ERR_CUTTER	Auto cutter error occurred.
CODE_ERR_MECHANICAL	Mechanical error occurred.
CODE_ERR_EMPTY	No paper is left in the roll paper end detector.
CODE_ERR_PARAM	An invalid parameter was passed.
CODE_ERR_MEMORY	Memory necessary for processing could not be allocated.
CODE_ERR_TIMEOUT	Failed to communicate with the devices within the specified time.
CODE_ERR_PROCESSING	Could not run the process.
CODE_ERR_ILLEGAL	This API was called while no communication had been started.
CODE_ERR_FAILURE	An unknown error occurred.

Exception

When the process fails, Epos2Exception with one of the following error status occurs.

Error status	Description
ERR_PARAM	An invalid parameter was passed.
ERR_FAILURE	An unknown error occurred.

Supplementary explanation

- ❑ This API cannot be used simultaneously with other APIs.
After executing this API, do not execute any other API until the callback is returned.
- ❑ Do not turn off the power supply to the printer while executing this API.
- ❑ If communication with the printer is disconnected during execution of this API, the printer may become unable to operate. In such a case, turn the power supply to the printer off and then on again.
- ❑ Communication with the printer disconnects as the printer automatically restarts during execution of this API. Reconnect as necessary.
In a network environment that uses DHCP, the IP address may change due to restart of the printer.
In such a case, search for the printer using [Discovery class](#) and reconnect.
When connected via USB, the USB device node may change due to restart of the printer.
In such a case, search for the printer using [Discovery class](#) and reconnect.
- ❑ This API can be used in the system configuration of the TM printer model and customer display model.
With the system configuration of the TM Printer + DM-D30 + barcode scanner model, this API can be used when connecting via *Bluetooth* or USB.
- ❑ This API cannot be used with SSL/TLS communication.

downloadFirmwareList

Acquires a list of firmware from the server.

The firmware list acquired by this API is notified to the listener registration method specified in the listener parameter.

Syntax

- ❑ `public void downloadFirmwareList(java.lang.String printerModel, FirmwareUpdateListener listener) throws Epos2Exception`
- ❑ `public void downloadFirmwareList(java.lang.String printerModel, java.lang.String option FirmwareUpdateListener listener) throws Epos2Exception`

Parameter

printerModel

Specifies the model name of the target printer.

Value	Description
TM-m10	TM-m10
TM-m30	TM-m30
TM-T88VI	TM-T88VI
TM-T88VI-iHUB	TM-T88VI-iHUB

option

Specifies the version of the target firmware.

Value	Description
-A	Ver.*.*A ESC/POS
-B	Ver.*.*B ESC/POS

Ver.*.*A ESC/POS:For OT-WL02/WL06 users

Ver.*.*B ESC/POS:For OT-WL05/WL06 users

Check the firmware release information for the detailed functions of each firmware version.

If you don't use a wireless LAN unit, you can choose either A or B.

listener

Registers the listener registration method that returns the processing result of this API.

```
- (void) onDownloadFirmwareList(int code, FirmwareInfo[]
firmwareList);
```

code

The processing result is stored.

Error status	Description
CODE_SUCCESS	Processed successfully.
CODE_ERR_CONNECT	Communication with the server failed.

firmwareList

A list of downloadable firmware is stored in Epos2FirmwareInfo in Array format.

Exception

When the process fails, Epos2Exception with one of the following error value occurs.

Error status	Description
ERR_PARAM	An invalid parameter was passed.
ERR_CONNECT	Communication with the server failed.
ERR_FAILURE	An unknown error occurred.

Supplementary explanation

- This API can be used in an environment where it can connect to both the Internet and a printer.
- This API cannot be used simultaneously with other APIs.
After executing this API, do not execute any other API until the callback is returned.
- Do not turn off the power supply to the printer while executing this API.
- This API can be used in the system configuration of the TM printer model and customer display model.
With the system configuration of the TM Printer + DM-D30 + barcode scanner model, this API can be used when connecting via *Bluetooth* or USB.
- This API cannot be used with SSL/TLS communication.
- If no firmware image exists on the server, the firmware list cannot be acquired.

getPrinterFirmwareInfo

Acquires the firmware information for the connected printer.

The firmware information acquired by this API is notified to the listener registration method specified in the listener parameter.

Syntax

```
public void getPrinterFirmwareInfo(int timeout,
    FirmwareUpdateListener listener) throws Epos2Exception
```

Parameter

timeout

Specifies the timeout period before acquisition of firmware information is complete in milliseconds.

Value	Description
Integer from 15000 to 60000	Timeout period (in milliseconds)
EPOS2_PARAM_DEFAULT	Specifies the default value (30000).

listener

Registers the listener registration method that returns the processing result of this API.

```
- (void) onReceiveFirmwareInformation(FirmwareInfo
    firmwareInfo);
```

firmwareInfo

The firmware information for the connected printer is stored.

Exception

When the process fails, Epos2Exception with one of the following error value occurs.

Error status	Description
ERR_PARAM	An invalid parameter was passed.
ERR_MEMORY	Memory necessary for processing could not be allocated.
ERR_TIMEOUT	Processing did not complete within the specified time period.
ERR_FAILURE	An unknown error occurred.
ERR_PROCESSING	Could not run the process.
ERR_ILLEGAL	This API was called while no communication had been started.

Supplementary explanation

- ❑ This API can be used in an environment where it can connect to both the Internet and a printer.
- ❑ This API cannot be used simultaneously with other APIs.
After executing this API, do not execute any other API until the callback is returned.
- ❑ Do not turn off the power supply to the printer while executing this API.
- ❑ This API can be used in the system configuration of the TM printer model and customer display model.
With the system configuration of the TM Printer + DM-D30 + barcode scanner model, this API can be used when connecting via *Bluetooth* or USB.
- ❑ This API cannot be used with SSL/TLS communication.

verifyUpdate

Compares the firmware of the connected printer with the firmware image specified by [updateFirmware](#).

Execute this API after executing [updateFirmware](#), and confirm that the printer firmware has been overwritten by the firmware image specified in [updateFirmware](#).

The processing result of this API is notified to the listener registration method specified in the listener parameter.

Syntax

```
public void verifyUpdate(FirmwareInfo targetFirmwareInfo,
    FirmwareUpdateListener listener) throws Epos2Exception
```

Parameter

targetFirmwareInfo

Specifies the firmware image version that you want to apply to the printer from the list acquired by [downloadFirmwareList](#).

Specifies the same firmware image as the one specified by the targetFirmwareInfo parameter of [updateFirmware](#).

listener

Registers the listener registration method that returns the processing result of this API.

```
- (void) onUpdateVerify:(int)code;
```

code

The processing result is stored.

Error status	Description
CODE_SUCCESS	Processed successfully.
CODE_ERR_DIFFERENT_MODEL	The compatible model of the firmware image specified in targetFirmwareInfo differs from the model name of the connected printer.
CODE_ERR_DIFFERENT_VERSION	The version of the firmware image specified in targetFirmwareInfo differs from the firmware version of the connected printer.
CODE_ERR_PARAM	An invalid parameter was passed.
CODE_ERR_MEMORY	Memory necessary for processing could not be allocated.
CODE_ERR_TIMEOUT	Processing did not complete within the specified time period.
CODE_ERR_DATA_CORRUPTED	The firmware image is corrupt.
CODE_ERR_PROCESSING	Could not run the process.
CODE_ERR_ILLEGAL	This API was called while no communication had been started.

Error status	Description
CODE_ERR_FAILURE	An unknown error occurred.

Exception

When the process fails, Epos2Exception with one of the following error value occurs.

Error status	Description
ERR_PARAM	An invalid parameter was passed. This API was called before updateFirmware was executed.
ERR_FAILURE	An unknown error occurred.

Supplementary explanation

- ❑ This API can be used in an environment where it can connect to both the Internet and a printer.
- ❑ This API cannot be used simultaneously with other APIs.
After executing this API, do not execute any other API until the callback is returned.
- ❑ Do not turn off the power supply to the printer while executing this API.
- ❑ This API can be used in the system configuration of the TM printer model and customer display model.
With the system configuration of the TM Printer + DM-D30 + barcode scanner model, this API can be used when connecting via *Bluetooth* or USB.
- ❑ This API cannot be used with SSL/TLS communication.

updateFirmware

Downloads the firmware image from the server and instructs the printer to overwrite the firmware image.

Execute [verifyUpdate](#) after executing this API, and confirm that the printer firmware has been overwritten by the firmware image.

The return value from this API is the result of instructing writing of the firmware image to the printer. It is not the execution result of the overall firmware update.

The progress and processing result of this API is notified to the listener registration method specified in the listener parameter.

Syntax

```
public void updateFirmware(FirmwareInfo
    targetFirmwareInfo, FirmwareUpdateListener listener,
    android.content.Context context) throws Epos2Exception
```

Parameter

targetFirmwareInfo

Specifies the firmware image version that you want to apply to the printer from the list acquired by [downloadFirmwareList](#).

listener

Registers the listener registration method that returns the progress and execution result of this API.

- Acquires the progress status
 - (void) onFirmwareUpdateProgress(String task, float progress);

task

The name of the executed process is stored.

Name	Description
Prepare	Under preparation
Download Firmware	Downloading the firmware image from the server
Sending firmware image	Sending the downloaded firmware image to the printer

progress

A value between 0.0 and 1.0 is stored according to the progress status of the executed process.

- Acquires the execution result
 - (void) onUpdateFirmware(int code, int maxWaitTime);

code

The processing result is stored.

Error status	Description
CODE_SUCCESS	Processed successfully.
CODE_ERR_DIFFERENT_MODEL	The compatible model of the firmware image specified in targetFirmwareInfo differs from the model name of the connected printer.
CODE_ERR_PARAM	An invalid parameter was passed.
CODE_ERR_MEMORY	Necessary memory could not be allocated.
CODE_ERR_CONNECT	No communication with the printer or server.
CODE_ERR_TIMEOUT	Processing did not complete within the specified time period.
CODE_ERR_IO	Could not access the firmware image downloaded from the server.
CODE_ERR_DATA_CORRUPTED	The firmware image is corrupt.
CODE_ERR_PROCESSING	Could not run the process.
CODE_ERR_ILLEGAL	This API was called while no communication had been started.
CODE_ERR_FAILURE	An unknown error occurred.

maxWaitTime

The maximum wait time to complete writing of the firmware image is stored.

Exception

When the process fails, Epos2Exception with one of the following error value occurs.

Error status	Description
ERR_PARAM	An invalid parameter was passed.
ERR_FAILURE	An unknown error occurred.

Supplementary explanation

- This API can be used in an environment where it can connect to both the Internet and a printer.
- This API cannot be used simultaneously with other APIs.
After executing this API, do not execute any other API until the callback is returned.
- Do not turn off the power supply to the printer while executing this API.
- Communication with the printer disconnects as the printer automatically restarts during execution of this API. Reconnect as necessary.
In a network environment that uses DHCP, the IP address may change due to restart of the printer. In such a case, search for the printer using [Discovery class](#) and reconnect.
When connected via USB, the USB device node may change due to restart of the printer. In such a case, search for the printer using [Discovery class](#) and reconnect.

- ❑ This API can be used in the system configuration of the TM printer model and customer display model. With the system configuration of the TM Printer + DM-D30 + barcode scanner model, this API can be used when connecting via *Bluetooth* or USB.
- ❑ This API cannot be used with SSL/TLS communication.
- ❑ When updating the firmware by executing this API, note the following points:
 - The time required to update depends on the interface.
 - About 15 minutes for a network connection
 - About 85 minutes for a *Bluetooth* connection
 - You cannot stop the update once it has started.
 - Check that the smart device is charged sufficiently.
 - Check that no errors have occurred in the printer.
 - Check that the printer's communication status is in good condition.
 - Do not operate the smart device while updating the firmware.
 - Do not disconnect the connection cable and power cable while updating the firmware.
 - Do not sleep the smart device while updating the firmware.

forceRecover

Forcibly sends the error recovery command from a recoverable error status (example: auto cutter error).

For details on recoverable errors, refer to the Technical Reference Guide of each printer.

The error status of this API is the result of sending data to the devices.

The processing result of the devices using this API is notified to the listener registration method set by the [setReceiveEventListener](#) API of the Printer class.

Syntax

```
public void forceRecover(int timeout) throws Epos2Exception
```

Parameter

timeout

Specifies the timeout period before completion of command transmission in milliseconds.

Value	Description
0 to 600000	Timeout period (in milliseconds)
Printer.PARAM_DEFAULT	Specifies the default value (10000).

Exception

When the process fails, Epos2Exception with one of the following error status occurs.

Error status	Description
ERR_MEMORY	Necessary memory could not be allocated.
ERR_FAILURE	An unknown error occurred.
ERR_PROCESSING	Could not run the process.
ERR_ILLEGAL	This API was called while no communication had been started.

Supplementary explanation

- ❑ After recovering from a recoverable error, the buffer of the printer is reset.
- ❑ For TM-H6000V, the “Command execution during offline” setting must be enabled.
Refer to TM-H6000V Utility User’s Manual for more information.
- ❑ Available during ePOS-Device XML control.

forcePulse

Forcibly sends the drawer kick command.

The error status of this API is the result of sending data to the devices.

The processing result of the devices using this API is notified to the listener registration method set by the [setReceiveEventListener](#) API of the Printer class.

Syntax

```
public void forcePulse(int drawer, int pulseTime, int timeout)
throws Epos2Exception
```

Parameter

drawer

Specifies the drawer kick connector.

Value	Description
Printer.DRAWER_2PIN	Drawer kick connector pin No.2
Printer.DRAWER_5PIN	Drawer kick connector pin No.5
Printer.PARAM_DEFAULT	Specifies the default (drawer kick connector pin No.2).

time

Specifies the on time of the drawer kick signal.

Value	Description
Printer.PULSE_100	100-msec signal
Printer.PULSE_200	200-msec signal
Printer.PULSE_300	300-msec signal
Printer.PULSE_400	400-msec signal
Printer.PULSE_500	500-msec signal
Printer.PARAM_DEFAULT	Specifies the default (100-msec signal).

timeout

Specifies the timeout period before completion of command transmission in milliseconds.

Value	Description
0 to 600000	Timeout period (in milliseconds)
Printer.PARAM_DEFAULT	Specifies the default value (10000).

Exception

When the process fails, Epos2Exception with one of the following error status occurs.

Error status	Description
ERR_PARAM	An invalid parameter was passed.
ERR_MEMORY	Memory necessary for processing could not be allocated.
ERR_FAILURE	An unknown error occurred.
ERR_PROCESSING	Could not run the process.
ERR_ILLEGAL	This API was called while no communication had been started.

Supplementary explanation

- The drawer and optional external buzzer cannot be connected simultaneously.
- For TM-H6000V, the “Command execution during offline” setting must be enabled.
Refer to TM-H6000V Utility User’s Manual for more information.
- Available during ePOS-Device XML control.

forceStopSound

Forcibly sends the buzzer sound command.

The error status of this API is the result of sending data to the devices.

The processing result of the devices using this API is notified to the listener registration method set by the [setReceiveEventListener](#) API of the Printer class.

Syntax

```
public void forceStopSound(int timeout) throws
Epos2Exception
```

Parameter

timeout

Specifies the timeout period before completion of command transmission in milliseconds.

Value	Description
0 to 600000	Timeout period (in milliseconds)
Printer.PARAM_DEFAULT	Specifies the default value (10000).

Exception

When the process fails, Epos2Exception with one of the following error status occurs.

Error status	Description
ERR_PARAM	An invalid parameter was passed.
ERR_MEMORY	Memory necessary for processing could not be allocated.
ERR_FAILURE	An unknown error occurred.
ERR_PROCESSING	Could not run the process.
ERR_ILLEGAL	This API was called while no communication had been started.

Supplementary explanation

- ❑ The drawer and optional external buzzer cannot be connected simultaneously.
- ❑ This API cannot be used if the printer is not equipped with a buzzer.
- ❑ For TM-H6000V, the “Command execution during offline” setting must be enabled.
Refer to TM-H6000V Utility User’s Manual for more information.
- ❑ Available during ePOS-Device XML control.

forceCommand

Forcibly sends the ESC/POS command.

The error status of this API is the result of sending data to the devices.

The processing result of the devices using this API is notified to the listener registration method set by the [setReceiveEventListener](#) API of the Printer class.

Syntax

```
public void (byte[] data, int timeout) throws Epos2Exception
```

Parameter

data

Forcibly sends the ESC/POS command.

Specifies the binary data.

timeout

Specifies the timeout period before completion of command transmission in milliseconds.

Value	Description
0 to 600000	Timeout period (in milliseconds)
Printer.PARAM_DEFAULT	Specifies the default value (10000).

Exception

When the process fails, Epos2Exception with one of the following error status occurs.

Error status	Description
ERR_PARAM	An invalid parameter was passed.
ERR_MEMORY	Memory necessary for processing could not be allocated.
ERR_FAILURE	An unknown error occurred.
ERR_PROCESSING	Could not run the process.
ERR_ILLEGAL	This API was called while no communication had been started.

Supplementary explanation

- ❑ For TM-H6000V, the “Command execution during offline” setting must be enabled.
Refer to TM-H6000V Utility User’s Manual for more information.
- ❑ Available during ePOS-Device XML control.

forceReset

Forcibly sends the printer reset command.

The error status of this API is the result of sending data to the devices.

The processing result of the devices using this API is notified to the listener registration method set by the [setReceiveEventListener](#) API of the Printer class.

Syntax

- public void forceReset(int timeout) throws Epos2Exception

Parameter

timeout

Specifies the timeout period before completion of command transmission in milliseconds.

Value	Description
0 to 600000	Timeout period (in milliseconds)
Printer.PARAM_DEFAULT	Specifies the default value (10000).

Exception

When the process fails, Epos2Exception with one of the following error status occurs.

Error status	Description
ERR_MEMORY	Necessary memory could not be allocated.
ERR_FAILURE	An unknown error occurred.
ERR_PROCESSING	Could not run the process.
ERR_ILLEGAL	This API was called while no communication had been started.

Supplementary explanation

- For TM-H6000V, the "Command execution during offline" setting must be enabled.
Refer to TM-H6000V Utility User's Manual for more information.
- Available during ePOS-Device XML control.

setStatusChangeListener

Registers a listener registration method for a status change event.

Syntax

```
public void setStatusChangeListener
(StatusChangeListener statusChangeListener)
```

Parameter

listener

Specifies an object which has a notification target method.

Listener interface

```
public interface StatusChangeListener extends EventListener
```

Listener registration method

```
void onPtrStatusChange(Printer printerObj, int eventType)
```

Parameter

printerObj

The callback source object is stored.

eventType

The type of the event that occurred is stored.

Event type	Description
Printer.EVENT_ONLINE	Online
Printer.EVENT_OFFLINE	Offline
Printer.EVENT_POWER_OFF	Power off
Printer.EVENT_COVER_CLOSE	Cover close
Printer.EVENT_COVER_OPEN	Cover open
Printer.EVENT_PAPER_OK	Paper remains.
Printer.EVENT_PAPER_NEAR_END	Paper has almost run out.
Printer.EVENT_PAPER_EMPTY	Paper has run out.
Printer.EVENT_DRAWER_HIGH	Drawer kick connector pin No.3 status = "H"
Printer.EVENT_DRAWER_LOW	Drawer kick connector pin No.3 status = "L"
Printer.EVENT_BATTERY_ENOUGH	Battery is enough.
Printer.EVENT_BATTERY_EMPTY	Battery has run out.

Supplementary explanation

- ❑ When this API is run multiple times, the listener registration method specified later takes effect.
- ❑ If null is specified in listener when calling this API, the registered listener registration method is canceled.

setReceiveEventListener

Registers a listener registration method for a print completion event.

Syntax

```
public void setReceiveEventListener (ReceiveListener
receiveListener)
```

Parameter

target

Specifies an object which has a notification target method.

Listener interface

```
public interface ReceiveListener extends EventListener
```

Listener registration method

```
void onPtrReceive (Printer printerObj, int code,
PrinterStatusInfo status, String printJobId)
```

Parameter

printerObj

The callback source object is stored.

code

The processing result is stored.

Error status	Description
CODE_SUCCESS	Print succeeded.
CODE_PRINTING	Printing
CODE_ERR_AUTORECOVER	Automatic recovery error occurred.
CODE_ERR_COVER_OPEN	Cover open error occurred.
CODE_ERR_CUTTER	Auto cutter error occurred.
CODE_ERR_MECHANICAL	Mechanical error occurred.
CODE_ERR_EMPTY	No paper is left in the roll paper end detector.
CODE_ERR_UNRECOVERABLE	Unrecoverable error occurred.
CODE_ERR_FAILURE	Error exists in the requested document syntax.
CODE_ERR_NOT_FOUND	Printer specified by the device ID does not exist.
CODE_ERR_SYSTEM	Error occurred with the printing system.
CODE_ERR_PORT	Error was detected with the communication port.
CODE_ERR_TIMEOUT	Print timeout occurred.

Error status	Description
CODE_ERR_JOB_NOT_FOUND	Specified print job ID does not exist.
CODE_ERR_SPOOLER	Print queue is full.
CODE_ERR_BATTERY_LOW	Battery has run out.
CODE_ERR_TOO_MANY_REQUESTS	The number of print jobs sent to the printer has exceeded the allowable limit.
CODE_ERR_REQUEST_ENTITY_TOO_LARGE	The size of the print job data exceeds the capacity of the printer.

status

Status at the timing when the process was run is stored as the PrinterStatusInfo type.

printJobId

- When the spooler function has been enabled, a print job ID is stored.
- When the spooler function has been disabled, null is stored.

Supplementary explanation

- When this API is run multiple times, the listener registration method specified later takes effect.
- If null is specified in listener when calling this API, the registered listener registration method is canceled.
- When a communication error occurs during ePOS-Device XML control, communication disconnection is not notified.
To notify the disconnection event, implement the [setConnectionEventListener](#).
- When controlling multiple printers at a time, identify which printer has finished printing by comparing the Printer object in the caller and the printerObj parameter.

interval

Updates the printer status (Printer.EVENT_POWER_OFF event) and specifies a notification interval. <obsolete>

Syntax

Setter

```
public void setInterval (int interval) throws Epos2Exception
```

Getter

```
public int getInterval ()
```

Value

Updates the printer status (Printer.EVENT_POWER_OFF event) and specifies a notification interval. The default value is 3,000.

Value	Description
Integer from 1000 to 60000	Interval to update the printer status (in milliseconds).
Printer.PARAM_DEFAULT	Specifies the default value (3000).

Exception

When the process fails, Epos2Exception with one of the following error status occurs.

Error status	Description
ERR_PARAM	An invalid parameter was passed.

Supplementary explanation

Events other than Printer.EVENT_POWER_OFF are updated and notified at an interval of less than 1 second. The update interval cannot be changed.

HybridPrinter class

HybridPrinter

Initializes the HybridPrinter class.

Syntax

```
public HybridPrinter(int lang, Context context) throws
Epos2Exception
```

Parameter

lang

Specifies the language of the printer.

Value	Description
HybridPrinter.MODEL_ANK	English (ANK specification)
HybridPrinter.MODEL_JAPANESE	Japanese
HybridPrinter.MODEL_CHINESE	Simplified Chinese
HybridPrinter.MODEL_TAIWAN	Traditional Chinese
HybridPrinter.MODEL_KOREAN	Korean
HybridPrinter.MODEL_THAI	Thai
HybridPrinter.MODEL_SOUTHASIA	South Asian specification

context

Specifies the application context.

Null can be specified when the log output function is not used.

Exception

When the process fails, Epos2Exception with one of the following error value occurs.

Error status	Description
ERR_PARAM	An invalid parameter was specified.
ERR_MEMORY	Necessary memory could not be allocated.
ERR_UNSUPPORTED	A language not supported was specified.

Supplementary explanation

When iterating a process, be sure to generate and destroy instances outside the iterated process and not iterate the process at a short interval.

Memory releasing by the OS may affect the process of the Epson ePOS SDK, resulting in an invalid operation.

connect

Starts communication with the printer.

Syntax

Public void connect(String target, int timeout) throws Epos2Exception

Parameter

target

Specifies the method of connecting to the printer by a character string.

The connection method varies according to the system configuration.

- TM Printer Models

<connection type>:<identifier>

I/F	Connection type	Identifier	Example
Wi-Fi/Ethernet	"TCP"	<ul style="list-style-type: none"> • IP address in IPv4 format • MAC address • Host name 	"TCP:192.168.192.168"
<i>Bluetooth</i>	"BT"	BD address	"BT:00:22:15:7D:70:9C"
USB	"USB"	Device node	"USB:/dev/udev/*"

To connect to the printer via SSL/TLS communication, specify using the following syntax.

<connection type>:<identifier>[<device ID>]

I/F	Connection type	Identifier	Example
Wi-Fi/Ethernet	"TCPS"	<ul style="list-style-type: none"> • IP address in IPv4 format • MAC address • Host name 	"TCPS:192.168.192.168[local_printer]"

- Customer Display Models

<connection type>:<identifier>

I/F	Connection type	Identifier	Example
Wi-Fi/Ethernet	"TCP"	<ul style="list-style-type: none"> • IP address in IPv4 format • MAC address • Host name 	"TCP:192.168.192.168"
<i>Bluetooth</i>	"BT"	BD address	"BT:00:22:15:7D:70:9C"
USB	"USB"	Device node	"USB:/dev/udev/*"

To connect to the printer via SSL/TLS communication, specify using the following syntax.

<connection type>:<identifier>[<device ID>]

I/F	Connection type	Identifier	Example
Wi-Fi/Ethernet	"TCPS"	<ul style="list-style-type: none"> IP address in IPv4 format MAC address Host name 	"TCPS:192.168.192.168[local_printer]"

timeout

Specifies the maximum time (in milliseconds) to wait for communication with the printer to be established.

Value	Description
Integer from 1000 to 300000	Maximum wait time before an error is returned (in milliseconds).
HybridPrinter.PARAM_DEFAULT	Specifies the default value (15000).

Exception

When the process fails, Epos2Exception with one of the following error value occurs.

Error status	Description
ERR_PARAM	An invalid parameter was specified.
ERR_CONNECT	Failed to open the device.
ERR_TIMEOUT	Failed to communicate with the devices within the specified time.
ERR_ILLEGAL	Tried to start communication with a printer with which communication had been already established.
ERR_MEMORY	Necessary memory could not be allocated.
ERR_FAILURE	An unknown error occurred.
ERR_PROCESSING	Could not run the process.
ERR_NOT_FOUND	The device could not be found.
ERR_IN_USE	The device was in use.
ERR_TYPE_INVALID	The device type is different.

Supplementary explanation

- ❑ When using multi-threading to connect to multiple printers or peripheral devices, this API and [disconnect](#) cannot be started for other printers or peripheral devices until this API finishes processing. Start the next process after this API finishes processing.
- ❑ The device ID is an arbitrary character string that is set when the peripheral device is registered to the TM printer (master).
For details, refer to the Technical Reference Guide of each printer.

- ❑ If you specify TCPS in the connection to a printer that does not support SSL/TLS communication, ERR_PARAM is returned.
- ❑ Devices other than printers are exclusively locked.

disconnect

Ends communication with the printer.

Syntax

Public void disconnect() throws Epos2Exception

Exception

When the process fails, Epos2Exception with one of the following error value occurs.

Error status	Description
ERR_ILLEGAL	Tried to end communication where it had not been established.
ERR_MEMORY	Necessary memory could not be allocated.
ERR_FAILURE	An unknown error occurred.
ERR_PROCESSING	Could not run the process.

Supplementary explanation

- ❑ When connected to the printer with *Bluetooth*, executing this API while a slip sheet is inserted by `readMicrData` causes the slip sheet to be ejected.
- ❑ Executing this API while waiting for paper insertion after executing `waitInsertion`, `readMicrData`, and `cleanMicrReader` cancels waiting for paper insertion.
At that time, processing result of `waitInsertion`, `readMicrData`, and `cleanMicrReader` is not notified.
- ❑ When using multi-threading to connect to multiple printers or peripheral devices, this API and `connect` cannot be started for other printers or peripheral devices until this API finishes processing. Start the next process after this API finishes processing.

startMonitor

Enables printer status event notification.

Acquires and updates the printer status at the interval specified by the [interval](#) property and returns it to the listener registration method registered by [setStatusChangeListener](#).

Syntax

```
public void startMonitor() throws Epos2Exception
```

Exception

When the process fails, Epos2Exception with one of the following error value occurs.

Error status	Description
ERR_ILLEGAL	This API was called while no communication had been started.

Supplementary explanation

During ESC/POS control, any ASB information items which have been changed during the update interval specified by the [interval](#) property are reported.

During ePOS-Device XML control, the ASB information at the time of update is reported.

stopMonitor

Disables status events.

Syntax

```
public void stopMonitor() throws Epos2Exception
```

Exception

When the process fails, Epos2Exception with one of the following error value occurs.

Error status	Description
ERR_ILLEGAL	This API was called while no communication had been started.

getStatus

Acquires the current status information.

Syntax

```
public HybridPrinterStatusInfo getStatus ()
```

Return value

The current status is returned in the HybridPrinterStatusInfo type.

The following status information is stored in the object as a property.

Stored status information can be acquired using the getter method of each property.

Printer status	Status	Description
connection: Connection status	HybridPrinter.TRUE	Connected
	HybridPrinter.FALSE	Disconnected
online: Online status	HybridPrinter.TRUE	Online
	HybridPrinter.FALSE	Offline
	HybridPrinter.UNKNOWN	Status is unknown.
coverOpen: Cover status	HybridPrinter.TRUE	Cover is open.
	HybridPrinter.FALSE	Cover is closed.
	HybridPrinter.UNKNOWN	Status is unknown.
paper: Paper status	HybridPrinter.PAPER_OK	Paper remains.
	HybridPrinter.PAPER_NEAR_END	Paper is running out.
	HybridPrinter.PAPER_EMPTY	Paper has run out.
	HybridPrinter.UNKNOWN	Status is unknown.
paperFeed: Paper feed	HybridPrinter.TRUE	Paper feed in progress
	HybridPrinter.FALSE	Stopped
	HybridPrinter.UNKNOWN	Status is unknown.
panelSwitch: Panel switch (Feed button) status	HybridPrinter.SWITCH_ON	Pressed
	HybridPrinter.SWITCH_OFF	Not pressed
	HybridPrinter.UNKNOWN	Status is unknown.
drawer: Drawer kick connector pin No.3 status	HybridPrinter.DRAWER_HIGH	High
	HybridPrinter.DRAWER_LOW	Low
	HybridPrinter.UNKNOWN	Status is unknown.

Printer status	Status	Description
errorStatus: Error status	HybridPrinter.NO_ERR	Normal
	HybridPrinter.MECHANICAL_ERR	Mechanical error occurred.
	HybridPrinter.AUTOCUTTER_ERR	Auto cutter error occurred.
	HybridPrinter.UNRECOVER_ERR	Unrecoverable error occurred.
	HybridPrinter.AUTORECOVER_ERR	Automatic recovery error occurred.
	HybridPrinter.UNKNOWN	Status is unknown.
autoRecoverError: Automatic recovery error status	HybridPrinter.HEAD_OVERHEAT	Head overheat error
	HybridPrinter.MOTOR_OVERHEAT	Motor driver IC overheat error
	HybridPrinter.WRONG_PAPER	Paper error
	HybridPrinter.COVER_OPEN	Cover is open.
	HybridPrinter.UNKNOWN	Status is unknown.
insertionWaiting: Paper insertion wait status	HybridPrinter .INSERTION_WAIT_SLIP	Waiting for slip sheet insertion
	HybridPrinter .INSERTION_WAIT_VALIDATION	Waiting for validation sheet insertion
	HybridPrinter.INSERTION_WAIT_MICR	Waiting for slip sheet insertion
	HybridPrinter.INSERTION_WAIT_NONE	Not waiting for paper insertion
	HybridPrinter.UNKNOWN	Status is unknown.
removalWaiting: Paper removal wait status	HybridPrinter.REMOVAL_WAIT_PAPER	Waiting for paper removal
	HybridPrinter.REMOVAL_WAIT_NONE	Not waiting for paper removal
	HybridPrinter.UNKNOWN	Status is unknown.
slipPaper: Status of paper conveyance route for the slip mechanism	HybridPrinter.SLIP_PAPER_OK	Paper remains.
	HybridPrinter.SLIP_PAPER_EMPTY	Paper has run out.
	HybridPrinter.UNKNOWN	Status is unknown.

Supplementary explanation

- ❑ If this API is called while communication is not available, printer states other than "connection" will be set to "Hybrid-Printer.UNKNOWN."
- ❑ The status object is set to the status at the timing of execution of this API and will not be updated.
- ❑ When a head overheat error occurs, HybridPrinter.UNKNOWN may be returned in autoRecoverError.
- ❑ HybridPrinter.INSERTION_WAIT_SLIP in insertionWaiting does not distinguish between slip sheet insertion for slip printing and endorsement printing.

sendData

Sends the print command and performs printing in the print method specified by [selectPaperType](#). The processing result of the devices using this API is notified to the listener registration method set by the [setReceiveEventListener](#) API of the HybridPrinter class.

Syntax

```
public void sendData (int timeout) throws Epos2Exception
```

Parameter

timeout

Specifies the timeout period before completion of printing in milliseconds.

Value	Description
Integer from 5000 to 600000	Timeout period (in milliseconds)
HybridPrinter.PARAM_DEFAULT	Specifies the default value (15000).

Exception

When the process fails, Epos2Exception with one of the following error value occurs.

Error status	Description
ERR_PARAM	An invalid parameter was specified.
ERR_ILLEGAL	The control commands have not been buffered. This API was called while no communication had been started.
ERR_MEMORY	Necessary memory could not be allocated.
ERR_FAILURE	An unknown error occurred.
ERR_PROCESSING	Could not run the process.

beginTransaction

Starts a transaction.

A transaction represents a single printing task such as printing a single sheet of receipt or coupon.

After this API is called, data until the transaction is terminated by [endTransaction](#) will be regarded as a single printing task.

Syntax

```
public void beginTransaction() throws Epos2Exception
```

Exception

When the process fails, Epos2Exception with one of the following error value occurs.

Error status	Description
ERR_ILLEGAL	This API was called while no communication had been started. Another transaction had been already started by this function.
ERR_FAILURE	An unknown error occurred.

endTransaction

Ends a transaction.

A transaction represents a single printing task such as printing a single sheet of receipt or coupon.

After [beginTransaction](#) is called, data until the transaction is terminated by this API will be regarded as a single printing task.

Syntax

```
public void endTransaction() throws Epos2Exception
```

Exception

When the process fails, Epos2Exception with one of the following error value occurs.

Error status	Description
ERR_ILLEGAL	This API was called while no communication had been started. This API was called while no transaction had been started.
ERR_FAILURE	An unknown error occurred.

Supplementary explanation

Do not execute this API during the period from paper insertion through paper eject during slip, endorsement, validation, and MICR control.

clearCommandBuffer

Clears the command buffer.

The contents buffered in the command buffer are retained until this API is called.

Syntax

```
public void clearCommandBuffer()
```

selectPaperType

Specifies a print method.

Syntax

```
public void selectPaperType(int paperType) throws
Epos2Exception
```

Parameter

paperType

Specifies a print method.

Value	Description
HybridPrinter.PAPER_TYPE_RECEIPT	Receipt printing
HybridPrinter.PAPER_TYPE_SLIP	Slip printing
HybridPrinter.PAPER_TYPE_ENDORSE	Endorsement printing
HybridPrinter.PAPER_TYPE_VALIDATION	Validation printing
HybridPrinter.PARAM_DEFAULT	Specifies the default (receipt printing).

Exception

When the process fails, Epos2Exception with one of the following error value occurs.

Error status	Description
ERR_PARAM	An invalid parameter was specified.
ERR_ILLEGAL	This API was called while no communication had been started. This API was called while waiting for paper insertion. This API was called while paper has already been inserted. This API was called while transmitting data. This API was called while waiting for paper removal.
ERR_CONNECT	Communication failed.
EPOS2_ERR_UNSUPPORTED	A print method not supported by the printer was specified.

Supplementary explanation

The print method specified by this API affects [waitInsertion](#) and [sendData](#) APIs.

waitInsertion

Causes the printer to wait for paper insertion.

After running this API, set the paper appropriate for the print method specified by the [selectPaperType](#).

The processing result of the devices using this API is notified to the listener registration method set by the [setReceiveEventListener](#) API of the HybridPrinter class.

Syntax

```
public void waitInsertion (int timeout) throws Epos2Execption
```

Parameter

timeout

Specifies the timeout period before completion of paper insertion in milliseconds.

Value	Description
Integer from 5000 to 600000	Timeout period (in milliseconds)
HybridPrinter.PARAM_DEFAULT	Specifies the default value (15000).

Exception

When the process fails, Epos2Exception with one of the following error value occurs.

Error status	Description
HybridPrinter.ERR_PARAM	An invalid parameter was specified.
HybridPrinter.ERR_ILLEGAL	This API was called while no communication had been started.
HybridPrinter.ERR_MEMORY	Necessary memory could not be allocated.
HybridPrinter.ERR_FAILURE	An unknown error occurred.
HybridPrinter.ERR_PROCESSING	Could not run the process.

cancelInsertion

Cancels the paper insertion wait status.

The processing result of the devices using this API is notified to the listener registration method set by the [setReceiveEventListener](#) API of the HybridPrinter class.

Syntax

```
public void cancelInsertion () throws Epos2Exception
```

Exception

When the process fails, Epos2Exception with one of the following error value occurs.

Error status	Description
ERR_ILLEGAL	<p>This API was called while no communication had been started.</p> <p>This API was called while receipt printing was specified as the print method.</p> <p>This API was called while not waiting for paper insertion.</p> <p>This API was called while paper has already been inserted.</p> <p>This API was called while reading MICR.</p> <p>This API was called while waiting for paper removal.</p>
ERR_MEMORY	Necessary memory could not be allocated.
ERR_FAILURE	An unknown error occurred.
ERR_PROCESSING	Could not run the process.

ejectPaper

Ejects the papers.

The processing result of the devices using this API is notified to the listener registration method set by the [setReceiveEventListener](#) API of the HybridPrinter class when the eject command has been transmitted to the printer.

Syntax

```
public void ejectPaper () throws Epos2Exception
```

Exception

When the process fails, Epos2Exception with one of the following error value occurs.

Error status	Description
ERR_ILLEGAL	This API was called while no communication had been started.
ERR_MEMORY	Necessary memory could not be allocated.
ERR_FAILURE	An unknown error occurred.
ERR_PROCESSING	Could not run the process.

Supplementary explanation

Cannot communicate with the printer until the paper ejected after receiving the callback is removed.

readMicrData

Reads MICR data.

Inserting a slip sheet after executing this API starts reading MICR.

The processing result of the devices using this API is notified to the listener registration method set by the [setReceiveEventListener](#) API of the HybridPrinter class.

Syntax

```
public void readMicrData (int micrFont, int timeout) throws
Epos2Exception
```

Parameter

micrFont

Specifies the font of characters to read.

Value	Description
HybridPrinter.MICR_FONT_E13B	Specifies E13B as the read font.
HybridPrinter.MICR_FONT_CMC7	Specifies CMC7 as the read font.
HybridPrinter.PARAM_DEFAULT	Specifies the default value (font E13B).

timeout

Specifies the timeout period before completion of MICR reading in milliseconds.

Value	Description
Integer from 5000 to 600000	Timeout period (in milliseconds)
HybridPrinter.PARAM_DEFAULT	Specifies the default value (15000).

Exception

When the process fails, Epos2Exception with one of the following error value occurs.

Error status	Description
ERR_PARAM	An invalid parameter was specified.
ERR_UNSUPPORTED	The printer is not equipped with MICR.
ERR_ILLEGAL	This API was called while no communication had been started.
ERR_MEMORY	Necessary memory could not be allocated.
ERR_FAILURE	An unknown error occurred.
ERR_PROCESSING	Could not run the process.

cleanMicrReader

Cleans the MICR mechanism.

Inserting a cleaning sheet after executing this API starts cleaning the MICR mechanism.

The processing result of the devices using this API is notified to the listener registration method set by the [setReceiveEventListener](#) API of the HybridPrinter class.

Syntax

```
public void cleanMicrReader (int timeout) throws
Epos2Exception
```

Parameter

timeout

Specifies the timeout period before completion of MICR mechanism cleaning in milliseconds.

Value	Description
Integer from 5000 to 600000	Timeout period (in milliseconds)
HybridPrinter.PARAM_DEFAULT	Specifies the default value (15000).

Exception

When the process fails, Epos2Exception with one of the following error value occurs.

Error status	Description
ERR_PARAM	An invalid parameter was specified.
ERR_UNSUPPORTED	The printer is not equipped with MICR.
ERR_ILLEGAL	This API was called while no communication had been started.
ERR_MEMORY	Necessary memory could not be allocated.
ERR_FAILURE	An unknown error occurred.
ERR_PROCESSING	Could not run the process.

forceRecover

Forcibly sends the error recovery command.

The processing result of the devices using this API is notified to the listener registration method set by the [setReceiveEventListener](#) API of the HybridPrinter class.

Syntax

```
public void forceRecover(int timeout) throws Epos2Exception
```

Parameter

timeout

Specifies the timeout period before completion of command transmission in milliseconds.

Value	Description
0 to 600000	Timeout period (in milliseconds)
HybridPrinter.PARAM_DEFAULT	Specifies the default value (10000).

Exception

When the process fails, Epos2Exception with one of the following error value occurs.

Error status	Description
ERR_CONNECT	Communication failed.
ERR_PARAM	An invalid parameter was specified.
ERR_MEMORY	Necessary memory could not be allocated.
ERR_FAILURE	An unknown error occurred.
ERR_PROCESSING	Could not run the process.

Supplementary explanation

- ❑ For TM-H6000V, the “Command execution during offline” setting must be enabled.
Refer to TM-H6000V Utility User’s Manual for more information.
- ❑ Available during ePOS-Device XML control.

forcePulse

Forcibly sends the drawer kick command.

The processing result of the devices using this API is notified to the listener registration method set by the [setReceiveEventListener](#) API of the HybridPrinter class.

Syntax

```
public void forcePulse(int drawer, int pulseTime, int timeout)
throws Epos2Exception
```

Parameter

drawer

Specifies the drawer kick connector.

Value	Description
HybridPrinter.DRAWER_2PIN	Drawer kick connector pin No.2
HybridPrinter.DRAWER_5PIN	Drawer kick connector pin No.5
HybridPrinter.PARAM_DEFAULT	Specifies the default (drawer kick connector pin No.2).

pulseTime

Specifies the on time of the drawer kick signal.

Value	Description
HybridPrinter.PULSE_100	100-msec signal
HybridPrinter.PULSE_200	200-msec signal
HybridPrinter.PULSE_300	300-msec signal
HybridPrinter.PULSE_400	400-msec signal
HybridPrinter.PULSE_500	500-msec signal
HybridPrinter.PARAM_DEFAULT	Specifies the default (100-msec signal).

timeout

Specifies the timeout period before completion of command transmission in milliseconds.

Value	Description
0 to 600000	Timeout period (in milliseconds)
HybridPrinter.PARAM_DEFAULT	Specifies the default value (10000).

Exception

When the process fails, Epos2Exception with one of the following error value occurs.

Error status	Description
ERR_CONNECT	Communication failed.
ERR_PARAM	An invalid parameter was specified.
ERR_MEMORY	Necessary memory could not be allocated.
ERR_FAILURE	An unknown error occurred.
ERR_PROCESSING	Could not run the process.

Supplementary explanation

- ❑ The drawer and optional external buzzer cannot be connected simultaneously.
- ❑ For TM-H6000V, the “Command execution during offline” setting must be enabled.
Refer to TM-H6000V Utility User’s Manual for more information.
- ❑ Available during ePOS-Device XML control.

forceCommand

Forcibly sends the ESC/POS command.

The processing result of the devices using this API is notified to the listener registration method set by the [setReceiveEventListener](#) API of the HybridPrinter class.

Syntax

```
public void forceCommand(byte[] data, int timeout) throws Epos2Exception
```

Parameter

data

Forcibly sends the ESC/POS command.

Specifies the binary data.

timeout

Specifies the timeout period before completion of command transmission in milliseconds.

Value	Description
0 to 600000	Timeout period (in milliseconds)
HybridPrinter.PARAM_DEFAULT	Specifies the default value (10000).

Exception

When the process fails, Epos2Exception with one of the following error value occurs.

Error status	Description
ERR_CONNECT	Communication failed.
ERR_PARAM	An invalid parameter was specified.
ERR_MEMORY	Necessary memory could not be allocated.
ERR_FAILURE	An unknown error occurred.
ERR_PROCESSING	Could not run the process.

Supplementary explanation

- ❑ For TM-H6000V, the “Command execution during offline” setting must be enabled.
Refer to TM-H6000V Utility User’s Manual for more information.
- ❑ Available during ePOS-Device XML control.

forceReset

Forcibly sends the printer reset command.

The processing result of the devices using this API is notified to the listener registration method set by the [setReceiveEventListener](#) API of the HybridPrinter class.

Syntax

```
public void forceReset(int timeout) throws Epos2Exception
```

Parameter

timeout

Specifies the timeout period before completion of command transmission in milliseconds.

Value	Description
0 to 600000	Timeout period (in milliseconds)
HybridPrinter.PARAM_DEFAULT	Specifies the default value (10000).

Exception

When the process fails, Epos2Exception with one of the following error value occurs.

Error status	Description
ERR_CONNECT	Communication failed.
ERR_PARAM	An invalid parameter was specified.
ERR_MEMORY	Necessary memory could not be allocated.
ERR_FAILURE	An unknown error occurred.
ERR_PROCESSING	Could not run the process.

Supplementary explanation

- ❑ For TM-H6000V, the “Command execution during offline” setting must be enabled.
Refer to TM-H6000V Utility User’s Manual for more information.
- ❑ Available during ePOS-Device XML control.

paperType

Acquires the print method setting information.

Syntax

Getter

```
public int getPaperType()
```

Value

Acquires the set print method information.

Value	Description
HybridPrinter.PAPER_TYPE_RECEIPT	Specifies receipt printing.
HybridPrinter.PAPER_TYPE_SLIP	Specifies slip printing.
HybridPrinter.PAPER_TYPE_ENDORSE	Specifies endorsement printing.
HybridPrinter.PAPER_TYPE_VALIDATION	Specifies validation printing.

Supplementary explanation

The [selectPaperType](#) API is used to change the set value.

interval

Specifies the interval to update the printer status.

Syntax

Setter

```
public void setInterval (int interval) throws Epos2Exception
```

Getter

```
public int getInterval ()
```

Value

Specifies the interval to update the printer status (in milliseconds). The default value is 3000.

Value	Description
Integer from 1000 to 600000	Interval to update the printer status (in milliseconds).
HybridPrinter.PARAM_DEFAULT	Specifies the default value (3000).

Exception

When the process fails, Epos2Exception with one of the following error value occurs.

Error status	Description
ERR_PARAM	An invalid parameter was specified.

Supplementary explanation

The new set value takes effect upon the next printer status notification.

waitTime

Specifies the time from insertion of a paper to start of insertion operation.

Syntax

Setter

```
public void setWaitTime (int time) throws Epos2Exception
```

Getter

```
public int getWaitTime ()
```

Value

Default: 500

Value	Description
Integer from 0 to 6400	Specifies the value in milliseconds.
HybridPrinter.PARAM_DEFAULT	Specifies the default value (500).

Exception

When the process fails, Epos2Exception with one of the following error value occurs.

Error status	Description
ERR_PARAM	An invalid parameter was specified.

Supplementary explanation

Set values are rounded down to the nearest 100 milliseconds.

Example: 1 -> 0, 101 -> 100, 150 -> 100

mode40Cpl

Enables or disables the 40cpl mode.

Syntax

Setter

```
public void setMode40Cpl (int mode) throws Epos2Exception
```

Getter

```
public int getMode40Cpl ()
```

Value

Default: 40cpl mode enabled

Value	Description
HybridPrinter.TRUE	40cpl mode enabled
HybridPrinter.FALSE	40cpl mode disabled
HybridPrinter.PARAM_DEFAULT	Specifies the default (40cpl mode enabled).

Exception

When the process fails, Epos2Exception with one of the following error value occurs.

Error status	Description
ERR_PARAM	An invalid parameter was specified.

Supplementary explanation

This API does not work in the page mode.

setStatusChangeListener

Registers a listener registration method for a status change event.

Syntax

```
public void setStatusChangeListener
(StatusChangeListener statusChangeListener)
```

Parameter

statusChangeListener

Specifies an object which has a notification target method.

Listener interface

```
public interface StatusChangeListener extends EventListener
```

Listener registration method

```
void onHybdStatusChange(HybridPrinter hybridPrinterObj,
int eventType)
```

Parameter

hybridPrinterObj

The callback source object is stored.

eventType

The type of the event that occurred is stored.

Event type	Description
HybridPrinter.EVENT_ONLINE	Online
HybridPrinter.EVENT_OFFLINE	Offline
HybridPrinter.EVENT_POWER_OFF	Power off
HybridPrinter.EVENT_COVER_CLOSE	Cover close
HybridPrinter.EVENT_COVER_OPEN	Cover open
HybridPrinter.EVENT_PAPER_OK	Paper remains.
HybridPrinter.EVENT_PAPER_NEAR_END	Paper has almost run out.
HybridPrinter.EVENT_PAPER_EMPTY	Paper has run out.
HybridPrinter.EVENT_DRAWER_HIGH	Drawer kick connector pin No.3 status = "H"
HybridPrinter.EVENT_DRAWER_LOW	Drawer kick connector pin No.3 status = "L"
HybridPrinter.EVENT_INSERTION_WAIT_SLIP	Waiting for slip sheet insertion
HybridPrinter.EVENT_INSERTION_WAIT_VALIDATION	Waiting for validation sheet insertion
HybridPrinter.EVENT_INSERTION_WAIT_MICR	Waiting for slip sheet insertion

Event type	Description
HybridPrinter.EVENT_INSERTION_WAIT_NONE	Not waiting for paper insertion
HybridPrinter.EVENT_REMOVAL_WAIT_PAPER	Waiting for paper removal
HybridPrinter.EVENT_REMOVAL_WAIT_NONE	Not waiting for paper removal
HybridPrinter.EVENT_SLIP_PAPER_OK	Paper remains in the paper conveyance route for the slip mechanism
HybridPrinter.EVENT_SLIP_PAPER_EMPTY	No paper in the paper conveyance route for the slip mechanism

Supplementary explanation

- ❑ When this API is run multiple times, the listener registration method specified later takes effect.
- ❑ If null is specified in listener when calling this API, the registered listener registration method is canceled.

setReceiveEventListener

Registers a listener registration method for a print completion event.

Syntax

```
public void setReceiveEventListener (ReceiveListener
receiveListener)
```

Parameter

target

Specifies an object which has a notification target method.

Listener interface

```
public interface ReceiveListener extends EventListener
```

Listener registration method

```
void onHybdReceive (HybridPrinter hybridPrinterObj, int
method, int code, String micrData, HybridPrinterStatusInfo
status)
```

Parameter

hybridPrinterObj

The callback source object is stored.

method

The method information is stored.

Method type	Description
HybridPrinter.METHOD_WAITINSERTION	Result of the waitInsertion API
HybridPrinter.METHOD_SENDDATA	Result of the sendDataAPI
HybridPrinter.METHOD_CANCELINSERTION	Result of the cancelInsertion API
HybridPrinter.METHOD_EJECTPAPER	Result of the ejectPaper API
HybridPrinter.METHOD_READMICRDATA	Result of the readMicrData API
HybridPrinter.METHOD_CLEANMICRREADER	Result of the cleanMicrReader API

code

The processing result is stored.

Code	Description
CODE_SUCCESS	Printing was successful.
CODE_CANCELED	Cancel the insertion wait status.
CODE_PRINTING	Printing

Code	Description
CODE_ERR_AUTORECOVER	Automatic recovery error occurred.
CODE_ERR_COVER_OPEN	Cover open error occurred.
CODE_ERR_CUTTER	Auto cutter error occurred.
CODE_ERR_MECHANICAL	Mechanical error occurred.
CODE_ERR_EMPTY	No paper is left in the roll paper end detector.
CODE_ERR_UNRECOVERABLE	Unrecoverable error occurred.
CODE_ERR_FAILURE	Error exists in the requested document syntax.
CODE_ERR_NOT_FOUND	Printer specified by the device ID does not exist.
CODE_ERR_SYSTEM	Error occurred with the printing system.
CODE_ERR_PORT	Error was detected with the communication port.
CODE_ERR_TIMEOUT	Print timeout occurred.
CODE_ERR_JOB_NOT_FOUND	Specified job ID does not exist.
CODE_ERR_SPOOLER	Print queue is full.
CODE_ERR_TOO_MANY_REQUESTS	Print data exceeding the printer firmware capacity was transmitted.
CODE_ERR_REQUEST_ENTITY_TOO_LARGE	Print data exceeding the maximum capacity per transfer was transmitted.
CODE_ERR_NO_MICR_DATA	MICR read result does not exist.
CODE_ERR_ILLEGAL_LENGTH	A slip sheet out of the standard was inserted.
CODE_ERR_NO_MAGNETIC_DATA	Magnetic waveform cannot be detected.
CODE_ERR_RECOGNITION	A character which cannot be analyzed was detected.
CODE_ERR_READ	Error occurred during MICR read operation.
CODE_ERR_NOISE_DETECTED	Noise error was detected.
CODE_ERR_COVER_OPEN	Cover open error occurred during MICR read operation.
CODE_ERR_PAPER_JAM	Paper jam error occurred during MICR read operation.
CODE_ERR_PAPER_PULLED_OUT	Paper removal was detected.
CODE_ERR_CANCEL_FAILED	Failed to cancel waiting for paper insertion.
CODE_ERR_PAPER_TYPE	Printer operation differs from the specified print method.
CODE_ERR_WAIT_INSERTION	Could not run the process while waiting for paper insertion.
CODE_ERR_ILLEGAL	The function was used in an illegal way.

Code	Description
CODE_ERR_INSERTED	Could not run the process while paper had already been inserted.
CODE_ERR_WAIT_REMOVAL	Could not run the process while waiting for paper removal.
CODE_ERR_DEVICE_BUSY	The specified device is in process and the process cannot be executed.

micData

MICR read data is stored.

status

Status at the timing when the process was run is stored as the HybridPrinterStatusInfo type.

Supplementary explanation

- ❑ When this API is run multiple times, the listener registration method specified later takes effect.
- ❑ If null is specified in listener when calling this API, the registered listener registration method is canceled.
- ❑ When a communication error occurs during ePOS-Device XML control, communication disconnection is not notified.
To notify the disconnection event, implement the [setConnectionEventListener](#).
- ❑ When controlling multiple printers at a time, identify which printer has finished printing by comparing the HybridPrinter object in the caller and the hybridPrinterObj parameter.

LineDisplay class

LineDisplay

Initializes the LineDisplay class.

Syntax

```
public LineDisplay(int displaySeries, Context context) throws Epos2Exception
```

Parameter

displaySeries

Specifies the model name of the target customer display.

Value	Description
LineDisplay.DM_D110	DM-D110
LineDisplay.DM_D210	DM-D210
LineDisplay.DM_D30	DM-D30

context

Specifies the application context.

Null can be specified when the log output function is not used.

Exception

When the process fails, Epos2Exception with one of the following error value occurs.

Error status	Description
ERR_PARAM	An invalid parameter was specified.
ERR_MEMORY	Necessary memory could not be allocated.

Supplementary explanation

When iterating a process, be sure to generate and destroy instances outside the iterated process and not iterate the process at a short interval.

Memory releasing by the OS may affect the process of the Epson ePOS SDK, resulting in an invalid operation.

connect

Starts communication with the customer display.

Syntax

Public void connect (String target int timeout) throws Epos2Exception

Parameter

target

Specifies the method of connecting to the printer by a character string.

The connection method varies according to the system configuration.

- Customer Display Models

<connection type>:<identifier>

I/F	Connection type	Identifier	Example
Wi-Fi/Ethernet	"TCP"	<ul style="list-style-type: none"> IP address in IPv4 format MAC address Host name 	"TCP:192.168.192.168"
<i>Bluetooth</i>	"BT"	BD address	"BT:00:22:15:7D:70:9C"
USB	"USB"	<ul style="list-style-type: none"> Device node Serial number Omitted 	"USB:/dev/udev/*" "USB:00000000000000000000" "USB:"

To connect to the printer via SSL/TLS communication, specify using the following syntax.

<connection type>:<identifier>[<device ID>]

I/F	Connection type	Identifier	Example
Wi-Fi/Ethernet	"TCPS"	<ul style="list-style-type: none"> IP address in IPv4 format MAC address Host name 	"TCPS:192.168.192.168[local_display]"

- TM Printer + DM-D30 + barcode scanner model

To connect via Wi-Fi/Ethernet network communication, specify using the following syntax.

<connection type>:<identifier>[<device ID>]

I/F	Connection type	Identifier	Example
Wi-Fi/Ethernet	"TCP"	<ul style="list-style-type: none"> • IP address in IPv4 format • MAC address • Host name 	"TCP:192.168.192.168[local_display]"

To connect via *Bluetooth* or USB, specify using the following syntax.

I/F	Connection type	Identifier	Example
<i>Bluetooth</i>	"BT"	BD address	"BT:00:22:15:7D:70:9C"
USB	"USB"	<ul style="list-style-type: none"> • Device node • Serial number • Omitted 	"USB:/dev/udev/*" "USB:00000000000000000000" "USB:"

- POS Terminal Model

<connection type>:<identifier>[<device ID>]

I/F	Connection type	Identifier	Example
Wi-Fi/Ethernet	<ul style="list-style-type: none"> • "TCP" • "TCPS" 	<ul style="list-style-type: none"> • IP address in IPv4 format • MAC address • Host name 	"TCP:192.168.192.168[local_display]"

To connect to the printer via SSL/TLS communication, specify TCPS in the connection type.

timeout

Specifies the maximum time (in milliseconds) to wait for communication with the printer to be established.

Value	Description
Integer from 1000 to 300000	Maximum wait time before an error is returned (in milliseconds).
LineDisplay.PARAM_DEFAULT	Specifies the default value (15000).

Exception

When the process fails, Epos2Exception with one of the following error value occurs.

Error status	Description
ERR_PARAM	An invalid parameter was passed.
ERR_CONNECT	Failed to open the device.

Error status	Description
ERR_TIMEOUT	Failed to communicate with the devices within the specified time. The printer is offline.
ERR_ILLEGAL	Tried to start communication with a printer with which communication had been already established.
ERR_MEMORY	Necessary memory could not be allocated.
ERR_FAILURE	An unknown error occurred.
ERR_PROCESSING	Could not run the process.
ERR_NOT_FOUND	The device could not be found.
ERR_IN_USE	The device was in use.
ERR_TYPE_INVALID	The device type is different.

Supplementary explanation

- ❑ Devices other than printers are exclusively locked.
- ❑ When using multi-threading to connect to multiple printers or peripheral devices, this API and [disconnect](#) cannot be started for other printers or peripheral devices until this API finishes processing. Start the next process after this API finishes processing.
- ❑ The device ID is an arbitrary character string that is set when the peripheral device is registered to the TM printer (master).
For details, refer to the Technical Reference Guide of each printer.
- ❑ When connecting through the USB, the identifiers that can be specified differ depending on the shape of the USB connector.
When the identifier is omitted, Android OS connects with the USB device found first.
When the Android terminal is set to the developer mode, you may not be able to connect through USB-A - Device Charging.

Identifier	Shape of the USB connector	
	USB-B	USB-A - Device Charging
Device node	✓	-
Serial number	-	✓
Omitted	✓	✓

- ❑ This API will succeed regardless of the connection status of the TM printer (master) and peripheral devices.

disconnect

Ends communication with the customer display.

Syntax

Public void disconnect() throws Epos2Exception

Exception

When the process fails, Epos2Exception with one of the following error value occurs.

Error status	Description
ERR_ILLEGAL	Tried to end communication where it had not been established.
ERR_MEMORY	Necessary memory could not be allocated.
ERR_FAILURE	An unknown error occurred.
ERR_PROCESSING	Could not run the process.
ERR_DISCONNECT	Failed to disconnect the device.

Supplementary explanation

When using multi-threading to connect to multiple printers or peripheral devices, this API and [connect](#) cannot be started for other printers or peripheral devices until this API finishes processing. Start the next process after this API finishes processing.

getStatus

Acquires the current status information.

Syntax

```
public DisplayStatusInfo getStatus()
```

Return value

The current status is returned in the DisplayStatusInfo type.

The following status information is stored in the object as a property.

Stored status information can be acquired using the getter method of each property.

Printer status	Status	Description
connection:	LineDisplay.TRUE	Connected
Connection status	LineDisplay.FALSE	Disconnected

Supplementary explanation

- ❑ The status object is set to the status at the timing of execution of this API and will not be updated.
- ❑ If this function is executed within a callback function, null will be returned.
- ❑ If "FALSE" is returned when connecting a DM-D30, the TM printer is not connected to the terminal.

sendData

Sends the command buffer.

The error status of this API is the result of sending data to the devices.

The processing result of the devices using this API is notified to the listener registration method set by the [setReceiveEventListener](#) API.

This API sends data buffered by an add-type API (e.g., [addText](#)).

Syntax

```
public void sendData() throw Epos2Exception
```

Exception

When the process fails, Epos2Exception with one of the following error value occurs.

Error status	Description
ERR_MEMORY	Necessary memory could not be allocated.
ERR_FAILURE	An unknown error occurred.
ERR_PROCESSING	Processing could not be executed.
ERR_ILLEGAL	The control commands have not been buffered. This API was called while no communication had been started.

clearCommandBuffer

Clears the command buffer.

The contents buffered in the command buffer are retained until this API is called.

Syntax

```
public void clearCommandBuffer()
```

addInitialize

Initializes the customer display. Initialization changes the customer display status as follows.

- ❑ All the displayed characters are erased and all the windows are destroyed.
- ❑ Cursor settings are initialized to the default and the cursor position is returned to the origin of the customer display.
- ❑ The display blinking and brightness settings are initialized to the default.

Syntax

```
public void addInitialize ()
```

Exception

When the process fails, Epos2Exception with one of the following error value occurs.

Error status	Description
ERR_MEMORY	Necessary memory could not be allocated.
ERR_FAILURE	An unknown error occurred.

addCreateWindow

Adds window configuration to the command buffer.
Up to four windows can be configured.

Syntax

```
public int addCreateWindow(int number, int x, int y, int width, int height, int scrollMode) throw Epos2Exception
```

Parameter

number

Specifies the window number.

Value	Description
Integer from 1 to 4	Window number

x

Specifies the x coordinate of the window origin on the customer display.

Value	Description
Integer from 1 to 20	X coordinate on the customer display

y

Specifies the y coordinate of the window origin on the customer display.

Value	Description
Integer from 1 to 2	Y coordinate on the customer display

width

Specifies the window width.

Value	Description
Integer from 1 to 20	Window width

height

Specifies the window height.

Value	Description
Integer from 1 to 2	Window height

scrollMode

Specifies the window scroll mode.

Value	Description
LineDisplay.SCROLL_OVERWRITE	When the current display position is at the rightmost position of the upper line, displaying a new character moves the display position to the leftmost position of the lower line. When the current display position is at the rightmost position of the lower line, displaying a new character moves the display position to the leftmost position of the upper line.
LineDisplay.SCROLL_VERTICAL	When the current display position is at the rightmost position of the upper line, displaying a new character moves the display position to the leftmost position of the lower line. When the current display position is at the rightmost position of the lower line, displaying a new character scrolls up the characters on the lower line and clears the lower line.
LineDisplay.SCROLL_HORIZONTAL	When the current display position is at the rightmost position, displaying a new character scrolls all the characters already displayed on the cursor line to the left by one character and the new character is displayed at the rightmost position.
LineDisplay.PARAM_DEFAULT	Specifies the default value (Overwrite).

Exception

When the process fails, Epos2Exception with one of the following error value occurs.

Error status	Description
ERR_PARAM	An invalid parameter was passed.
ERR_MEMORY	Memory necessary for processing could not be allocated.
ERR_FAILURE	An unknown error occurred.

Supplementary explanation

To add a window, be careful so that the existing window(s) should not be overlapped by the new window on the customer display.

addDestroyWindow

Adds a command to destroy the window defined by [addCreateWindow](#) to the command buffer.

Syntax

```
public void addDestroyWindow(int number) throw
Epos2Exception
```

Parameter

number

Specifies the number of the window to destroy.

Value	Description
Integer from 1 to 4	Number of the window to destroy

Exception

When the process fails, Epos2Exception with one of the following error value occurs.

Error status	Description
ERR_PARAM	An invalid parameter was passed.
ERR_MEMORY	Memory necessary for processing could not be allocated.
ERR_FAILURE	An unknown error occurred.

addSetCurrentWindow

Adds a command to move to another window to the command buffer.

Specify one of the windows defined by [addCreateWindow](#) to set it as the new current window.

The cursor will move to the origin of the new window.

Syntax

```
public void addSetCurrentWindow(int number) throw
Epos2Exception
```

Parameter

number

Specifies a window number of a destination window.

Value	Description
Integer from 1 to 4	Window number of a destination window

Exception

When the process fails, Epos2Exception with one of the following error value occurs.

Error status	Description
ERR_PARAM	An invalid parameter was passed.
ERR_MEMORY	Memory necessary for processing could not be allocated.
ERR_FAILURE	An unknown error occurred.

addClearCurrentWindow

Adds a window clear command for the current window to the command buffer.

Syntax

```
public void addClearCurrentWindow() throw Epos2Exception
```

Exception

When the process fails, Epos2Exception with one of the following error value occurs.

Error status	Description
ERR_MEMORY	Memory necessary for processing could not be allocated.
ERR_FAILURE	An unknown error occurred.

addSetCursorPosition

Adds cursor position setting to the command buffer.

Syntax

```
public void addSetCursorPosition(int x, int y) throw
Epos2Exception
```

Parameter

x

Specifies the destination x coordinate.

Value	Description
Integer from 1 to 20	Destination x coordinate

y

Specifies the destination y coordinate.

Value	Description
Integer from 1 to 2	Destination y coordinate

Exception

When the process fails, Epos2Exception with one of the following error value occurs.

Error status	Description
ERR_PARAM	An invalid parameter was passed.
ERR_MEMORY	Memory necessary for processing could not be allocated.
ERR_FAILURE	An unknown error occurred.

Supplementary explanation

Use [addMoveCursorPosition](#) to move within a window.

addMoveCursorPosition

Adds cursor position setting within the current window to the command buffer.

Syntax

```
public void addMoveCursorPosition(int position) throw
Epos2Exception
```

Parameter

position

Specifies the new cursor position within the current window.

Value	Description
LineDisplay.MOVE_TOP_LEFT	Sets the new position to the top left edge.
LineDisplay.MOVE_TOP_RIGHT	Sets the new position to the top right edge.
LineDisplay.MOVE_BOTTOM_LEFT	Sets the new position to the bottom left edge.
LineDisplay.MOVE_BOTTOM_RIGHT	Sets the new position to the bottom right edge.
LineDisplay.PARAM_DEFAULT	Specifies the default value (top left edge).

Exception

When the process fails, Epos2Exception with one of the following error value occurs.

Error status	Description
ERR_PARAM	An invalid parameter was passed.
ERR_MEMORY	Memory necessary for processing could not be allocated.
ERR_FAILURE	An unknown error occurred.

addSetCursorType

Adds cursor display setting to the command buffer.

Syntax

```
public void addSetCursorType(int type) throw Epos2Exception
```

Parameter

type

Specifies the cursor display method.

Value	Description
LineDisplay.CURSOR_NONE	No cursor display
LineDisplay.CURSOR_UNDERLINE	Underscore
LineDisplay.PARAM_DEFAULT	Specifies the default value (no cursor display).

Exception

When the process fails, Epos2Exception with one of the following error value occurs.

Error status	Description
ERR_PARAM	An invalid parameter was passed.
ERR_MEMORY	Necessary memory could not be allocated.
ERR_FAILURE	An unknown error occurred.

addText

Adds string display setting to the command buffer.

Syntax

- ❑ `public void addText(String data)` throws `Epos2Exception`
- ❑ `public void addText(String data, int lang)` throws `Epos2Exception`
- ❑ `public void addText(String data, int x, int y)` throws `Epos2Exception`
- ❑ `public void addText(String data, int x, int y, int lang)` throws `Epos2Exception`

Parameter

data

Specifies the string to display.

lang

Specifies the language to display the string.

Value	Description
<code>LineDisplay.LANG_EN</code> (default)	English
<code>LineDisplay.LANG_JA</code>	Japanese
<code>LineDisplay.PARAM_DEFAULT</code>	Specifies the default value (English).

x

Specifies the x coordinate of the display position.

Value	Description
Integer from 1 to 20	X coordinate of the display position

y

Specifies the y coordinate of the display position.

Value	Description
Integer from 1 to 2	Y coordinate of the display position

Exception

When the process fails, `Epos2Exception` with one of the following error value occurs.

Error status	Description
ERR_PARAM	An invalid parameter was passed.
ERR_MEMORY	Necessary memory could not be allocated.
ERR_FAILURE	An unknown error occurred.

Supplementary explanation

- ❑ Parameters x and y specify coordinates with the origin at the top left of the customer display.
- ❑ If the coordinates of the display position are omitted, the coordinates of the cursor position upon execution of [addText](#) are used.

addReverseText

Adds reverse text display setting to the command buffer.

Syntax

- ❑ `public void addReverseText(String data)` throws `Epos2Exception`
- ❑ `public void addReverseText(String data, int lang)` throws `Epos2Exception`
- ❑ `public void addReverseText(String data, int x, int y)` throws `Epos2Exception`
- ❑ `public void addReverseText(String data, int x, int y, int lang)` throws `Epos2Exception`

Parameter

data

Specifies the string to display.

lang

Specifies the language to display the string.

Value	Description
<code>LineDisplay.LANG_EN</code> (default)	English
<code>LineDisplay.LANG_JA</code>	Japanese
<code>LineDisplay.PARAM_DEFAULT</code>	Specifies the default value (English).

x

Specifies the x coordinate of the display position.

Value	Description
Integer from 1 to 20	X coordinate of the display position

y

Specifies the y coordinate of the display position.

Value	Description
Integer from 1 to 2	Y coordinate of the display position

Exception

When the process fails, `Epos2Exception` with one of the following error value occurs.

Error status	Description
ERR_PARAM	An invalid parameter was passed.
ERR_MEMORY	Necessary memory could not be allocated.
ERR_FAILURE	An unknown error occurred.

Supplementary explanation

- ❑ Parameters x and y specify coordinates with the origin at the top left of the customer display.
- ❑ If the coordinates of the display position are omitted, the coordinates of the cursor position upon execution of [addText](#) are used.

addMarqueeText

Adds marquee display setting to the command buffer.

The marquee is displayed on a single line in the horizontal scroll mode, without regard to the scroll mode setting of the display window.

Syntax

```
public void addMarqueeText(String data ,int format, int
unitWait, int repeatWait, int repeatCount, int lang) throws
Epos2Exception
```

Parameter

data

Specifies the string to display.

format

Specifies how to display the string.

Value	Description
LineDisplay.MARQUEE_WALK	Displays the text from the rightmost position of the window.
LineDisplay.MARQUEE_PLACE	Displays the text from the leftmost position of the window.
LineDisplay.PARAM_DEFAULT	Specifies the default value (Walk).

unitWait

Specifies the display interval per character (in milliseconds).

Value	Description
Integer from 1 to 2000	Display interval per character (in milliseconds).

repeatWait

Specifies the display repeat interval (in milliseconds).

Value	Description
Integer from 1 to 2000	Display repeat interval (in milliseconds)

repeatCount

Specifies the display repeat count.

Value	Description
Integer from 1 to 127	Display repeat count
0	Unlimited

lang

Specifies the language to display the string.

Value	Description
LineDisplay.LANG_EN	English
LineDisplay.LANG_JA	Japanese
LineDisplay.PARAM_DEFAULT	Specifies the default value (English).

Exception

When the process fails, Epos2Exception with one of the following error value occurs.

Error status	Description
ERR_PARAM	An invalid parameter was passed.
ERR_MEMORY	Memory necessary for processing could not be allocated.
ERR_FAILURE	An unknown error occurred.

Supplementary explanation

- ❑ When using DM-D30 and when using a combination of TM-H6000V with DM-D110/DM-D210, "0" is only allowed in repeatCount.
- ❑ When controlling DM-D30, its marquee display may be distorted if the interval for displaying text is too short due to the characteristics of the LCD.
It is recommended to set unitWait and repeatWait so that the interval for displaying text is 600 msec or longer.

addSetBlink

Adds screen blink setting to the command buffer.

Syntax

```
public void addSetBlink(int interval) throws Epos2Exception
```

Parameter

interval

Specifies the blink interval (in milliseconds). The setting value is rounded to the nearest 50 milliseconds.

Value	Description
Integer from 1 to 12700	Blink interval (in milliseconds)
0	Continuously lit
LineDisplay.PARAM_DEFAULT	Specifies the default (continuously lit).

Exception

When the process fails, Epos2Exception with one of the following error value occurs.

Error status	Description
ERR_PARAM	An invalid parameter was passed.
ERR_MEMORY	Memory necessary for processing could not be allocated.
ERR_FAILURE	An unknown error occurred.

addSetBrightness

Adds brightness setting of the customer display to the command buffer.

Syntax

```
public void addSetBrightness(int brightness) throws
Epos2Exception
```

Parameter

brightness

Specifies the brightness value of the customer display.

Value	Description
LineDisplay.BRIGHTNESS_20	Sets the customer display brightness to 20%.
LineDisplay.BRIGHTNESS_40	Sets the customer display brightness to 40%.
LineDisplay.BRIGHTNESS_60	Sets the customer display brightness to 60%.
LineDisplay.BRIGHTNESS_100	Sets the customer display brightness to 100%.
LineDisplay.PARAM_DEFAULT	Specifies the default value (brightness 100%).

Exception

When the process fails, Epos2Exception with one of the following error value occurs.

Error status	Description
ERR_PARAM	An invalid parameter was passed.
ERR_MEMORY	Memory necessary for processing could not be allocated.
ERR_FAILURE	An unknown error occurred.

addShowClock

Adds time display setting to the command buffer.

Displaying the time clears all the displayed text. When another command is sent while the time is displayed, the time disappears.

Syntax

```
public void addShowClock() throws Epos2Exception
```

Exception

When the process fails, Epos2Exception with one of the following error value occurs.

Error status	Description
ERR_MEMORY	Memory necessary for processing could not be allocated.
ERR_FAILURE	An unknown error occurred.

Supplementary explanation

Not available for DM-D30.

addCommand

Adds the ESC/POS command to the command buffer.

Syntax

```
public void addCommand(byte[] data) throws Epos2Exception
```

Parameter

data

Specifies the ESC/POS command.

Specifies the binary data.

Exception

When the process fails, Epos2Exception with one of the following error value occurs.

Error status	Description
ERR_PARAM	An invalid parameter was passed.
ERR_MEMORY	Memory necessary for processing could not be allocated.
ERR_FAILURE	An unknown error occurred.

Supplementary explanation

- ❑ Refer to the following URL for details of the ESC/POS command.
https://reference.epson-biz.com/modules/ref_escpos_dm_d_en/
- ❑ Epson ePOS SDK does not check the commands sent using this API.
 If the commands interfere with Epson ePOS SDK operations, other APIs may work wrongly or status values may become invalid.
 This API should be used with a full understanding of ESC/POS commands and the customer display specifications.

setReceiveEventListener

Registers a listener registration method for a display completion event.

Syntax

```
public void setReceiveEventListener (ReceiveListener listener)
```

Parameter

listener

Specifies an object which has a notification target method.

Listener interface

```
public interface ReceiveListener extends EventListener
```

Listener registration method

```
void onDispReceive (LineDisplay displayObj, int code)
```

Parameter

displayObj

The callback source object is stored.

code

The processing result is stored.

Error status	Description
CODE_SUCCESS	Display completed.
CODE_ERR_NOT_FOUND	The device was not found.
CODE_ERR_INVALID_WINDOW	An unregistered window was specified.
CODE_ERR_PORT	An internal communication error with the device occurred.
CODE_ERR_TIMEOUT	A timeout error occurred during communication with the device.
CODE_ERR_TOO_MANY_REQUESTS	The number of display data sent to the display has exceeded the allowable limit.
CODE_ERR_AUTORECOVER	Automatic recovery error occurred.
CODE_ERR_COVER_OPEN	Cover open error occurred.
CODE_ERR_CUTTER	Auto cutter error occurred.
CODE_ERR_MECHANICAL	Mechanical error occurred.
CODE_ERR_EMPTY	No paper is left in the roll paper end detector.
CODE_ERR_UNRECOVERABLE	Unrecoverable error occurred.

Error status	Description
CODE_ERR_BATTERY_LOW	Battery has run out.
CODE_ERR_FAILURE	An unknown error occurred.

Supplementary explanation

- ❑ When this API is run multiple times, the listener registration method specified later takes effect.
- ❑ If null is specified in listener when calling this API, the registered listener registration method is canceled.
- ❑ When a communication error occurs during ePOS-Device XML control, communication disconnection is not notified.

To notify the disconnection event, implement the [setConnectionEventListener](#).

Keyboard class

Keyboard

Initializes the Keyboard class.

Syntax

```
public Keyboard(Context context) throws Epos2Exception
```

Parameter

context

Specifies the application context.

Null can be specified when the log output function is not used.

Exception

When the process fails, Epos2Exception with one of the following error value occurs.

Error status	Description
ERR_MEMORY	Necessary memory could not be allocated.

Supplementary explanation

When iterating a process, be sure to generate and destroy instances outside the iterated process and not iterate the process at a short interval.

Memory releasing by the OS may affect the process of the Epson ePOS SDK, resulting in an invalid operation.

connect

Starts communication with the keyboard.

Syntax

Public void connect(String target, int timeout) throws Epos2Exception

Parameter

target

Specifies the method of connecting to the printer by a character string.

The connection method varies according to the system configuration.

<connection type>:<identifier>[<device ID>]

I/F	Connection type	Identifier	Example
Wi-Fi/Ethernet	<ul style="list-style-type: none"> "TCP" "TCPS" 	<ul style="list-style-type: none"> IP address in IPv4 format MAC address Host name 	"TCP:192.168.192.168[local_keyboard]"

To connect to the printer via SSL/TLS communication, specify TCPS in the connection type.

timeout

Specifies the maximum time (in milliseconds) to wait for communication with the printer to be established.

Value	Description
Integer from 1000 to 300000	Maximum wait time before an error is returned (in milliseconds).
Keyboard.PARAM_DEFAULT	Specifies the default value (15000).

Exception

When the process fails, Epos2Exception with one of the following error value occurs.

Error status	Description
ERR_PARAM	An invalid parameter was passed.
ERR_CONNECT	Failed to open the device.
ERR_TIMEOUT	Failed to communicate with the devices within the specified time.
ERR_ILLEGAL	Tried to start communication with a printer with which communication had been already established.
ERR_MEMORY	Necessary memory could not be allocated.
ERR_FAILURE	An unknown error occurred.
ERR_PROCESSING	Could not run the process.

Error status	Description
ERR_NOT_FOUND	The device could not be found.
ERR_IN_USE	The device was in use.
ERR_TYPE_INVALID	The device type is different.

Supplementary explanation

- ❑ The device ID is an arbitrary character string that is set when the peripheral device is registered to the TM printer (master).
For details, refer to the Technical Reference Guide of each printer.
- ❑ When using multi-threading to connect to multiple printers or peripheral devices, this API and [disconnect](#) cannot be started for other printers or peripheral devices until this API finishes processing. Start the next process after this API finishes processing.
- ❑ This API will succeed regardless of the connection status of the TM printer (master) and peripheral devices.
- ❑ Devices other than printers are exclusively locked.

disconnect

Ends communication with the keyboard.

Syntax

Public void disconnect() throws Epos2Exception

Exception

When the process fails, Epos2Exception with one of the following error value occurs.

Error status	Description
ERR_ILLEGAL	Tried to end communication where it had not been established.
ERR_MEMORY	Necessary memory could not be allocated.
ERR_FAILURE	An unknown error occurred.
ERR_PROCESSING	Could not run the process.
ERR_DISCONNECT	Failed to disconnect the device.

Supplementary explanation

When using multi-threading to connect to multiple printers or peripheral devices, this API and [connect](#) cannot be started for other printers or peripheral devices until this API finishes processing. Start the next process after this API finishes processing.

getStatus

Acquires the current status information.

Syntax

```
public KeyboardStatusInfo getStatus ()
```

Return value

The current status is returned in the KeyboardStatusInfo type.

The following status information is stored in the object as a property.

Stored status information can be acquired using the getter method of each property.

Printer status	Status	Description
connection:	Keyboard.TRUE	Connected
Connection status	Keyboard.FALSE	Disconnected

Supplementary explanation

- ❑ The status object is set to the status at the timing of execution of this API and will not be updated.
- ❑ If this function is executed within a callback function, null will be returned.

setPrefix

Sets the list of prefixes for string entry.

Sets a key code which is recognized as the start of a string to accept keyboard input as a sequence of strings.

Syntax

```
public void setPrefix(int[] prefixes) throws Epos2Exception
```

Parameter

prefixes

Specifies the key code arrangement.

Refer to [Key code list](#) for the key codes.

Specifying null disables setPrefix.

Exception

When the process fails, Epos2Exception with one of the following error value occurs.

Error status	Description
ERR_PARAM	An invalid parameter was passed.
ERR_CONNECT	Communication failed.
ERR_MEMORY	Memory necessary for processing could not be allocated.
ERR_FAILURE	An unknown error occurred.

Supplementary explanation

Entering NULL or "" clears the current setting.

getPrefix

Acquires the list of prefixes currently set.

Syntax

```
public int[] getPrefix()
```

Return value

The list of prefixes currently set by setPrefix is returned.

setKeyPressEventListener

Registers a listener registration method for a key press event.

Syntax

```
public void setKeyPressEventListener (KeyPressListener
listener)
```

Parameter

listener

Specifies an object which has a notification target method.

Listener interface

```
public interface KeyPressListener extends EventListener
```

Listener registration method

```
void onKbdKeyPress (Keyboard keyboardObj, int keyCode,
String ascii)
```

Parameter

keyboardObj

The callback source object is stored.

keyCode

The code of the pressed key is stored.

ascii

The character corresponding to the code of the pressed key is stored. If no character corresponds to the key code, "" (blank character) is stored.

Depending on the keyboard used, double-byte characters may be entered.

Supplementary explanation

- ❑ When this API is run multiple times, the listener registration method specified later takes effect.
- ❑ If null is specified in listener when calling this API, the registered listener registration method is canceled.

setReadStringEventListener

Registers a listener registration method which receives characters starting with one of the strings specified by [setPrefix](#) and ending with the Enter key as a string.

Syntax

```
public void setReadStringEventListener (ReadStringListener listener)
```

Parameter

listener

Specifies an object which has a notification target method.

Listener interface

```
public interface ReadStringListener extends EventListener
```

Listener registration method

```
void onKbdReadString (Keyboard keyboardObj, String readString, int prefix)
```

Parameter

keyboardObj

The callback source object is stored.

readString

The detected string is stored.

prefix

Key code recognized as the start of a string is stored.

Supplementary explanation

- ❑ When this API is run multiple times, the listener registration method specified later takes effect.
- ❑ If null is specified in listener when calling this API, the registered listener registration method is canceled.

POSKeyboard class

PosKeyboard

Initializes the PosKeyboard class.

Syntax

```
public PosKeyboard(Context context) throws Epos2Exception
```

Parameter

context

Specifies the application context.

Null can be specified when the log output function is not used.

Exception

When the process fails, Epos2Exception with one of the following error value occurs.

Error status	Description
ERR_MEMORY	Necessary memory could not be allocated.

Supplementary explanation

When iterating a process, be sure to generate and destroy instances outside the iterated process and not iterate the process at a short interval.

Memory releasing by the OS may affect the process of the Epson ePOS SDK, resulting in an invalid operation.

connect

Starts communication with the POS keyboard.

Syntax

```
public void connect(String target, int timeout) throws Epos2Exception
```

Parameter

target

Specifies the method of connecting to the printer by a character string.

Specify the connection method using the following syntax.

<connection type>:<identifier>[<device ID>]

I/F	Connection type	Identifier	Description
Wi-Fi/Ethernet	<ul style="list-style-type: none"> "TCP" "TCPS" 	<ul style="list-style-type: none"> IP address in IPv4 format MAC address Host name 	"TCP:192.168.192.168[local_pos keyboard]"

To connect to the printer via SSL/TLS communication, specify TCPS in the connection type.

timeout

Specifies the maximum time (in milliseconds) to wait for communication with the printer to be established.

Value	Description
Integer from 1000 to 300000	Maximum wait time before an error is returned (in milliseconds).
Poskeyboard.PARAM_DEFAULT	Specifies the default value (15000).

Exception

When the process fails, Epos2Exception with one of the following error value occurs.

Error status	Description
ERR_PARAM	An invalid parameter was passed.
ERR_CONNECT	Failed to open the device.
ERR_TIMEOUT	Failed to communicate with the devices within the specified time.
ERR_ILLEGAL	Tried to start communication with a printer with which communication had been already established.
ERR_MEMORY	Necessary memory could not be allocated.
ERR_FAILURE	An unknown error occurred.
ERR_PROCESSING	Could not run the process.

Error status	Description
ERR_NOT_FOUND	The printer could not be found.
ERR_IN_USE	The device was in use.
ERR_TYPE_INVALID	The device type is different.

Supplementary explanation

- ❑ The device ID is a logical device name that is set when the POS keyboard is registered to the TM printer (master). For details, refer to the TM-DT Series Peripheral Device Control Guide.
- ❑ When using multi-threading to connect to multiple printers or peripheral devices, this API and [disconnect](#) cannot be started for other printers or peripheral devices until this API finishes processing. Start the next process after this API finishes processing.
- ❑ Devices other than printers are exclusively locked.

disconnect

Ends communication with the POS keyboard.

Syntax

```
public void disconnect() throws Epos2Exception
```

Exception

When the process fails, Epos2Exception with one of the following error value occurs.

Error status	Description
ERR_ILLEGAL	Tried to end communication where it had not been established.
ERR_MEMORY	Necessary memory could not be allocated.
ERR_FAILURE	An unknown error occurred.
ERR_PROCESSING	Could not run the process.
ERR_DISCONNECT	Failed to disconnect the device.

Supplementary explanation

When using multi-threading to connect to multiple printers or peripheral devices, this API and [connect](#) cannot be started for other printers or peripheral devices until this API finishes processing. Start the next process after this API finishes processing.

getStatus

Acquires the current status information.

Syntax

```
public PosKeyboardStatusInfo getStauts()
```

Return value

The current status is returned in the PosKeyboardStatusInfo type.

The following status information is stored in the object as a property.

Stored status information can be acquired using the getter method of each property.

Keyboard status	Status	Description
connection:	PosKeyboard.TRUE	Connected
Connection status	PosKeyboard.FALSE	Disconnected

Supplementary explanation

- ❑ The status object is set to the status at the timing of execution of this API and will not be updated.
- ❑ If this function is executed within a callback function, null will be returned.

setKeyPressEventListener

Registers a listener registration method for a key press event.

Syntax

```
public void setKeyPressEventListener(KeyPressListener listener)
```

Parameter

listener

Specifies an object which has a notification target method.

Listener interface

```
public interface KeyPressListener extends EventListener
```

Listener registration method

```
void onPosKbdKeyPress(PosKeyboard keyboardObj, int posKeyCode)
```

Parameter

keyboardObj

The callback source object is stored.

posKeyCode

The code of the pressed key is stored.

Supplementary explanation

- ❑ When this API is run multiple times, the listener registration method specified later takes effect.
- ❑ If null is specified in listener when calling this API, the registered listener registration method is canceled.

BarcodeScanner class

BarcodeScanner

Initializes the BarcodeScanner class.

Syntax

```
public BarcodeScanner(Context context) throws
Epos2Exception
```

Parameter

context

Specifies the application context.

Null can be specified when the log output function is not used.

Exception

When the process fails, Epos2Exception with one of the following error value occurs.

Error status	Description
ERR_MEMORY	Necessary memory could not be allocated.

Supplementary explanation

When iterating a process, be sure to generate and destroy instances outside the iterated process and not iterate the process at a short interval.

Memory releasing by the OS may affect the process of the Epson ePOS SDK, resulting in an invalid operation.

connect

Starts communication with the barcode scanner.

Syntax

Public void connect (String target, int timeout) throws Epos2Exception

Parameter

target

Specifies the method of connecting to the printer by a character string.

The connection method varies according to the system configuration.

- TM Printer + DM-D30 + barcode scanner model/
TM Printer + barcode scanner model

To connect via Wi-Fi/Ethernet network communication, specify using the following syntax.

<connection type>:<identifier>[<device ID>]

I/F	Connection type	Identifier	Example
Wi-Fi/Ethernet	"TCP"	<ul style="list-style-type: none"> • IP address in IPv4 format • MAC address • Host name 	"TCP:192.168.192.168[local_scanner]"

To connect via *Bluetooth* or *USB*, specify using the following syntax.

<connection type>:<identifier>

I/F	Connection type	Identifier	Example
<i>Bluetooth</i>	"BT"	BD address	"BT:00:22:15:7D:70:9C"
USB	"USB"	<ul style="list-style-type: none"> • Device node • Serial number • Omitted 	"USB:/dev/udev/*" "USB:00000000000000000000" "USB:"

- POS Terminal Model

<connection type>:<identifier>[<device ID>]

I/F	Connection type	Identifier	Example
Wi-Fi/Ethernet	<ul style="list-style-type: none"> • "TCP" • "TCPS" 	<ul style="list-style-type: none"> • IP address in IPv4 format • MAC address • Host name 	"TCP:192.168.192.168[local_scanner]"

To connect to the printer via SSL/TLS communication, specify TCPS in the connection type.

timeout

Specifies the maximum time (in milliseconds) to wait for communication with the printer to be established.

Value	Description
Integer from 1000 to 300000	Maximum wait time before an error is returned (in milliseconds).
BarcodeScanner.PARAM_DEFAULT	Specifies the default value (15000).

Exception

When the process fails, Epos2Exception with one of the following error value occurs.

Error status	Description
ERR_PARAM	An invalid parameter was passed.
ERR_CONNECT	Failed to open the device.
ERR_TIMEOUT	Failed to communicate with the devices within the specified time.
ERR_ILLEGAL	Tried to start communication with a printer with which communication had been already established.
ERR_MEMORY	Necessary memory could not be allocated.
ERR_FAILURE	An unknown error occurred.
ERR_PROCESSING	Could not run the process.
ERR_NOT_FOUND	The device could not be found.
ERR_IN_USE	The device was in use.
ERR_TYPE_INVALID	The device type is different.

Supplementary explanation

- ❑ The device ID is an arbitrary character string that is set when the peripheral device is registered to the TM printer (master).
For details, refer to the Technical Reference Guide of each printer.
- ❑ When using multi-threading to connect to multiple printers or peripheral devices, this API and [disconnect](#) cannot be started for other printers or peripheral devices until this API finishes processing. Start the next process after this API finishes processing.
- ❑ When connecting through the USB, the identifiers that can be specified differ depending on the shape of the USB connector.
When the identifier is omitted, Android OS connects with the USB device found first.
When the Android terminal is set to the developer mode, you may not be able to connect through USB-A - Device Charging.

Identifier	Shape of the USB connector	
	USB-B	USB-A - Device Charging
Device node	✓	-
Serial number	-	✓
Omitted	✓	✓

- ❑ This API will succeed regardless of the connection status of the TM printer (master) and peripheral devices.
- ❑ Set the barcode reader suffix (delimiter) to CR (carriage return code). Data cannot be obtained using any other settings.
- ❑ Devices other than printers are exclusively locked. Do not control the scanner and printer connected to the scanner from multiple applications at the same time.
- ❑ If a combination of TM Printer + barcode scanner is used on a connection established via *Bluetooth* or USB, the barcode data read during printing is notified after the printing is complete.

disconnect

Ends communication with the barcode scanner.

Syntax

Public void disconnect () throws Epos2Exception

Exception

When the process fails, Epos2Exception with one of the following error value occurs.

Error status	Description
ERR_ILLEGAL	Tried to end communication where it had not been established.
ERR_MEMORY	Necessary memory could not be allocated.
ERR_FAILURE	An unknown error occurred.
ERR_PROCESSING	Could not run the process.
ERR_DISCONNECT	Failed to disconnect the device.

Supplementary explanation

When using multi-threading to connect to multiple printers or peripheral devices, this API and [connect](#) cannot be started for other printers or peripheral devices until this API finishes processing. Start the next process after this API finishes processing.

getStatus

Acquires the current status information.

Syntax

```
public ScannerStatusInfo getStatus ()
```

Return value

The current status is returned in the ScannerStatusInfo type.

The following status information is stored in the object as a property.

Stored status information can be acquired using the getter method of each property.

Printer status	Status	Description
connection:	BarcodeScanner.TRUE	Connected
Connection status	BarcodeScanner.FALSE	Disconnected

Supplementary explanation

- ❑ The status object is set to the status at the timing of execution of this API and will not be updated.
- ❑ If this function is executed within a callback function, null will be returned.
- ❑ If a combination of TM Printer + barcode scanner is used on a connection established via *Bluetooth* or *USB*, the connection status of TM Printer and the barcode scanner is obtained. If the combination is used by some other connection method, the connection status of the smart device and TM Printer is obtained.

setScanEventListener

Registers a listener registration method for a barcode data entry event.

Syntax

```
public void setScanEventListener (ScanListener listener)
```

Parameter

listener

Specifies an object which has a notification target method.

Listener interface

```
public interface ScanListener extends EventListener
```

Listener registration method

```
void onScanData (BarcodeScanner scannerObj, String scanData)
```

Parameter

scannerObj

The callback source object is stored.

scanData

The detected string is stored.

Supplementary explanation

- ❑ When this API is run multiple times, the listener registration method specified later takes effect.
- ❑ If null is specified in listener when calling this API, the registered listener registration method is canceled.
- ❑ The notification timing of the barcode data entry event differs depending on how it is connected. Refer to the description of the target parameter of the [connect](#) API for details.

MSR class

Msr

Initializes the Msr class.

Syntax

```
public Msr(Context context) throws Epos2Exception
```

Parameter

context

Specifies the application context.

Null can be specified when the log output function is not used.

Exception

When the process fails, Epos2Exception with one of the following error value occurs.

Error status	Description
ERR_MEMORY	Necessary memory could not be allocated.

Supplementary explanation

When iterating a process, be sure to generate and destroy instances outside the iterated process and not iterate the process at a short interval.

Memory releasing by the OS may affect the process of the Epson ePOS SDK, resulting in an invalid operation.

connect

Starts communication with the MSR.

Syntax

```
public void connect(String target, int timeout) throws Epos2Exception
```

Parameter

target

Specifies the method of connecting to the printer by a character string.

Specify the connection method using the following syntax.

<connection type>:<identifier>[<device ID>]

I/F	Connection type	Identifier	Description
Wi-Fi/Ethernet	<ul style="list-style-type: none"> "TCP" "TCPS" 	<ul style="list-style-type: none"> IP address in IPv4 format MAC address Host name 	"TCP:192.168.192.168[local_msr]"

To connect to the printer via SSL/TLS communication, specify TCPS in the connection type.

timeout

Specifies the maximum time (in milliseconds) to wait for communication with the printer to be established.

Value	Description
Integer from 1000 to 300000	Maximum wait time before an error is returned (in milliseconds).
Msr.PARAM_DEFAULT	Specifies the default value (15000).

Exception

When the process fails, Epos2Exception with one of the following error value occurs.

Error status	Description
ERR_PARAM	An invalid parameter was passed.
ERR_CONNECT	Failed to open the device.
ERR_TIMEOUT	Failed to communicate with the devices within the specified time.
ERR_ILLEGAL	Tried to start communication with a printer with which communication had been already established.
ERR_MEMORY	Necessary memory could not be allocated.
ERR_FAILURE	An unknown error occurred.
ERR_PROCESSING	Could not run the process.

Error status	Description
ERR_NOT_FOUND	The printer could not be found.
ERR_IN_USE	The device was in use.
ERR_TYPE_INVALID	The device type is different.

Supplementary explanation

- ❑ The device ID is set when the MSR is registered to the TM printer (master).
The value differs depending on the control method.

Control method	Device ID	Reference
Device control program	Logical device name	TM-DT Series Peripheral Device Control Guide
Device control script	Arbitrary character string	Technical Reference Guide of the printer

- ❑ When using multi-threading to connect to multiple printers or peripheral devices, this API and [disconnect](#) cannot be started for other printers or peripheral devices until this API finishes processing. Start the next process after this API finishes processing.
- ❑ Devices other than printers are exclusively locked.

disconnect

Ends communication with the MSR.

Syntax

```
public void disconnect() throws Epos2Exception
```

Exception

When the process fails, Epos2Exception with one of the following error value occurs.

Error status	Description
ERR_ILLEGAL	Tried to end communication where it had not been established.
ERR_MEMORY	Necessary memory could not be allocated.
ERR_FAILURE	An unknown error occurred.
ERR_PROCESSING	Could not run the process.
ERR_DISCONNECT	Failed to disconnect the device.

Supplementary explanation

When using multi-threading to connect to multiple printers or peripheral devices, this API and [connect](#) cannot be started for other printers or peripheral devices until this API finishes processing. Start the next process after this API finishes processing.

getStatus

Acquires the current status information.

Syntax

```
public MsrStatusInfo getStauts()
```

Return value

The current status is returned in the MsrStatusInfo type.

The following status information is stored in the object as a property.

Stored status information can be acquired using the getter method of each property.

Keyboard status	Status	Description
connection:	Msr.TRUE	Connected
Connection status	Msr.FALSE	Disconnected

Supplementary explanation

- ❑ The status object is set to the status at the timing of execution of this API and will not be updated.
- ❑ If this function is executed within a callback function, null will be returned.

setDataEventListener

Registers a listener registration method for a card data detection event.

Syntax

```
public void setDataEventListener(DataListener listener)
```

Parameter

listener

Specifies an object which has a notification target method.

Listener interface

```
public interface DataListener extends EventListener
```

Listener registration method

```
void onData(Msr msrObj, Data data)
```

Parameter

msrObj

The callback source object is stored.

data

Acquires the read card data.

The result is stored in the Data structure.

Property	Description
String track1	Entire data of track 1
String track2	Entire data of track 2
String track4	Entire data of track 4 (JIS2 track)
String accountNumber	Account number
String expirationData	Expiration date ("YYMM" format)
String surname	Surname
String firstName	First Name
String middleInitial	Middle name/initial
String title	Title
String serviceCode	Service code
String track1_dd	Arbitrary data of track 1
String track2_dd	Arbitrary data of track 2

Supplementary explanation

- ❑ When this API is run multiple times, the listener registration method specified later takes effect.
- ❑ If null is specified in listener when calling this API, the registered listener registration method is canceled.

SimpleSerial class

SimpleSerial

Initializes the SimpleSerial class.

Syntax

```
public SimpleSerial(Context context) throws Epos2Exception
```

Parameter

context

Specifies the application context.

Null can be specified when the log output function is not used.

Exception

When the process fails, Epos2Exception with one of the following error value occurs.

Error status	Description
ERR_MEMORY	Necessary memory could not be allocated.

Supplementary explanation

When iterating a process, be sure to generate and destroy instances outside the iterated process and not iterate the process at a short interval.

Memory releasing by the OS may affect the process of the Epson ePOS SDK, resulting in an invalid operation.

connect

Starts communication with the serial communication device.

Syntax

Public void connect(String target, int timeout) throws Epos2Exception

Parameter

target

Specifies the method of connecting to the printer by a character string.

Specify the connection method using the following syntax.

<connection type>:<identifier>[<device ID>]

I/F	Connection type	Identifier	Example
Wi-Fi/Ethernet	<ul style="list-style-type: none"> "TCP" "TCPS" 	<ul style="list-style-type: none"> IP address in IPv4 format MAC address Host name 	"TCP:192.168.192.168[local_serial]"

To connect to the printer via SSL/TLS communication, specify TCPS in the connection type.

timeout

Specifies the maximum time (in milliseconds) to wait for communication with the printer to be established.

Value	Description
Integer from 1000 to 300000	Maximum wait time before an error is returned (in milliseconds).
SimpleSerial.PARAM_DEFAULT	Specifies the default value (15000).

Exception

When the process fails, Epos2Exception with one of the following error value occurs.

Error status	Description
ERR_PARAM	An invalid parameter was passed.
ERR_CONNECT	Failed to open the device.
ERR_TIMEOUT	Failed to communicate with the devices within the specified time.
ERR_ILLEGAL	Tried to start communication with a printer with which communication had been already established.
ERR_MEMORY	Necessary memory could not be allocated.
ERR_FAILURE	An unknown error occurred.
ERR_PROCESSING	Could not run the process.

Error status	Description
ERR_NOT_FOUND	The device could not be found.
ERR_IN_USE	The device was in use.
ERR_TYPE_INVALID	The device type is different.

Supplementary explanation

- ❑ The device ID is an arbitrary character string that is set when the peripheral device is registered to the TM printer (master).
For details, refer to the Technical Reference Guide of each printer.
- ❑ When using multi-threading to connect to multiple printers or peripheral devices, this API and [disconnect](#) cannot be started for other printers or peripheral devices until this API finishes processing. Start the next process after this API finishes processing.
- ❑ This API will succeed regardless of the connection status of the TM printer (master) and peripheral devices.
- ❑ Devices other than printers are exclusively locked.

disconnect

Ends communication with the serial communication device.

Syntax

Public void disconnect () throws Epos2Exception

Exception

When the process fails, Epos2Exception with one of the following error value occurs.

Error status	Description
ERR_ILLEGAL	Tried to end communication where it had not been established.
ERR_MEMORY	Necessary memory could not be allocated.
ERR_FAILURE	An unknown error occurred.
ERR_PROCESSING	Could not run the process.
ERR_DISCONNECT	Failed to disconnect the device.

Supplementary explanation

When using multi-threading to connect to multiple printers or peripheral devices, this API and [connect](#) cannot be started for other printers or peripheral devices until this API finishes processing. Start the next process after this API finishes processing.

getStatus

Acquires the current status information.

Syntax

```
public SerialStatusInfo getStatus ()
```

Return value

The current status is returned in the SerialStatusInfo type.

The following status information is stored in the object as a property.

Stored status information can be acquired using the getter method of each property.

Printer status	Status	Description
connection:	SimpleSerial.TRUE	Connected
Connection status	SimpleSerial.FALSE	Disconnected

Supplementary explanation

- ❑ The status object is set to the status at the timing of execution of this API and will not be updated.
- ❑ If this function is executed within a callback function, null will be returned.

sendCommand

Transfers a command.

The error status of this API is the result of sending data to the devices.

The processing result of the devices using this API is notified to the listener registration method set by the [setReceiveEventListener](#) API.

Syntax

```
public void sendCommand(byte[] data) throws
Epos2Exception
```

Parameter

data

Specifies the command.

Exception

When the process fails, Epos2Exception with one of the following error value occurs.

Error status	Description
ERR_PARAM	An invalid parameter was passed.
ERR_MEMORY	Memory necessary for processing could not be allocated.
ERR_FAILURE	An unknown error occurred.
ERR_ILLEGAL	This API was called while no communication had been started.

setReceiveEventListener

Registers a listener registration method for a reception event from the device.

Syntax

```
public void setReceiveEventListener(ReceiveListener listener)
```

Parameter

listener

Specifies an object which has a notification target method.

Listener interface

```
public interface ReceiveListener extends EventListener
```

Listener registration method

```
void onSimpleSerialReceive (SimpleSerial serialObj, byte[] data)
```

Parameter

serialObj

The callback source object is stored.

data

Receives reception data.

Supplementary explanation

- ❑ When this API is run multiple times, the listener registration method specified later takes effect.
- ❑ If null is specified in listener when calling this API, the registered listener registration method is canceled.
- ❑ When a communication error occurs during ePOS-Device XML control, communication disconnection is not notified.
To notify the disconnection event, implement the [setConnectionEventListener](#).

GermanyFiscalElement Class

GermanyFiscalElement

Initializes the GermanyFiscalElement class.

Syntax

```
public GermanyFiscalElement(android.content.Context
context) throws Epos2Exception
```

Parameter

context

Specifies the application context.

Null can be specified when the log output function is not used.

Exception

When the process fails, Epos2Exception with one of the following error value occurs.

Error status	Description
ERR_MEMORY	Memory necessary for processing could not be allocated.

Supplementary explanation

When iterating a process, be sure to generate and destroy instances outside the iterated process and not iterate the process at a short interval.

Memory releasing by the OS may affect the process of the Epson ePOS SDK, resulting in an invalid operation.

When using it with multiple printers connected, make sure to generate a dedicated instance for each printer.

connect

Starts communication with German fiscal element (TSE).

Syntax

```
public void connect(java.lang.String target,int timeout) throws Epos2Exception
```

Parameter

target

Specifies the method of connecting to the printer by a character string.

The connection method varies according to the system configuration.

- TM Printer Models

<connection type>:<identifier>

I/F	Connection type	Identifier	Example
Wi-Fi/Ethernet	"TCP"	<ul style="list-style-type: none"> • IP address in IPv4 format • MAC address • Host name 	"TCP:192.168.192.168"
<i>Bluetooth</i>	"BT"	BD address	"BT:00:22:15:7D:70:9C"
USB	"USB"	<ul style="list-style-type: none"> • Device node • Serial number • Omitted 	"USB:/dev/udev/*" "USB:00000000000000000000" "USB:"

- Customer Display Models

<connection type>:<identifier>

I/F	Connection type	Identifier	Example
Wi-Fi/Ethernet	"TCP"	<ul style="list-style-type: none"> • IP address in IPv4 format • MAC address • Host name 	"TCP:192.168.192.168"
<i>Bluetooth</i>	"BT"	BD address	"BT:00:22:15:7D:70:9C"
USB	"USB"	<ul style="list-style-type: none"> • Device node • Serial number • Omitted 	"USB:/dev/udev/*" "USB:00000000000000000000" "USB:"

To connect to the printer via SSL/TLS communication, specify using the following syntax.

<connection type>:<identifier>[<device ID>]

I/F	Connection type	Identifier	Example
Wi-Fi/Ethernet	"TCPS"	<ul style="list-style-type: none"> IP address in IPv4 format MAC address Host name 	"TCPS:192.168.192.168[local_TSE]"

- TM Printer + DM-D30 + barcode scanner model/
TM Printer + barcode scanner model

To connect via Wi-Fi/Ethernet network communication, specify using the following syntax.

<connection type>:<identifier>[<device ID>]

I/F	Connection type	Identifier	Example
Wi-Fi/Ethernet	"TCP"	<ul style="list-style-type: none"> IP address in IPv4 format MAC address Host name 	"TCP:192.168.192.168[local_TSE]"

The device ID is fixed as [local_TSE].

To connect via *Bluetooth* or USB, specify using the following syntax.

<connection type>:<identifier>

I/F	Connection type	Identifier	Example
<i>Bluetooth</i>	"BT"	BD address	"BT:00:22:15:7D:70:9C"
USB	"USB"	<ul style="list-style-type: none"> Device node Serial number Omitted 	"USB:/dev/udev/*" "USB:00000000000000000000" "USB:"

- POS Terminal Model

<connection type>:<identifier>[<device ID>]

I/F	Connection type	Identifier	Example
Wi-Fi/Ethernet	<ul style="list-style-type: none"> "TCP" "TCPS" 	<ul style="list-style-type: none"> IP address in IPv4 format MAC address Host name 	"TCP:192.168.192.168[local_TSE]"

To connect to the printer via SSL/TLS communication, specify TCPS in the connection type.

timeout

Specifies the maximum time (in milliseconds) to wait for communication with the printer to be established.

Value	Description
Integer from 1000 to 300000	Maximum wait time before an error is returned (in milliseconds).
Print.PARAM_DEFAULT	Specifies the default value (15000).

Exception

When the process fails, Epos2Exception with one of the following error value occurs.

Error status	Description
ERR_PARAM	An invalid parameter was passed.
ERR_CONNECT	Failed to open the device.
ERR_TIMEOUT	Failed to communicate with the devices within the specified time.
ERR_ILLEGAL	Tried to start communication with a printer with which communication had been already established.
ERR_MEMORY	Necessary memory could not be allocated.
ERR_FAILURE	An unknown error occurred.
ERR_PROCESSING	Could not run the process.
ERR_NOT_FOUND	The device could not be found.
ERR_IN_USE	The device was in use.
ERR_TYPE_INVALID	The device type is different.

Supplementary explanation

- ❑ When communication with the printer is no longer necessary, be sure to call [disconnect](#) to terminate it.
- ❑ When using multi-threading to connect to multiple printers or peripheral devices, this API and [disconnect](#) cannot be started for other printers or peripheral devices until this API finishes processing. Start the next process after this API finishes processing.
- ❑ The printer status is returned to the event registered with the Printer class.
For details, refer to Chapter 2 "Programming Flow" and Chapter 6 "To use the same printer from multiple mobile devices."
- ❑ The device ID is an arbitrary character string that is set when the peripheral device is registered to the TM printer (master).
For details, refer to the Technical Reference Guide of each printer.
- ❑ If you are using DHCP to assign the IP address of the printer, specify the MAC address or host name of the printer as the identifier.
- ❑ If you specify the host name of the printer as the identifier, use in the environment where it can be found by the DNS server.

- ❑ When connecting through the USB, the identifiers that can be specified differ depending on the shape of the USB connector.
When the identifier is omitted, Android OS connects with the USB device found first.
When the Android terminal is set to the developer mode, you may not be able to connect through USB-A - Device Charging.

Identifier	Shape of the USB connector	
	USB-B	USB-A - Device Charging
Device node	✓	-
Serial number	-	✓
Omitted	✓	✓

- ❑ This API will succeed regardless of the connection status of the TM printer (master) and peripheral devices.
- ❑ Devices other than printers are exclusively locked.

disconnect

Ends communication with the German fiscal element (TSE).

Syntax

```
public void disconnect() throws Epos2Exception
```

Exception

When the process fails, Epos2Exception with one of the following error value occurs.

Error status	Description
ERR_ILLEGAL	Tried to end communication where it had not been established.
ERR_MEMORY	Necessary memory could not be allocated.
ERR_FAILURE	An unknown error occurred.
ERR_PROCESSING	Could not run the process.
ERR_DISCONNECT	Failed to disconnect the device.

Supplementary explanation

When using multi-threading to connect to multiple printers or peripheral devices, this API and [connect](#) cannot be started for other printers or peripheral devices until this API finishes processing.

getStatus

Acquires the connection status with German fiscal element (TSE).

Syntax

```
public GermanyFiscalElementStatusInfo getStatus()
```

Return value

The current status is returned in the GermanyFiscalElementStatusInfo type.

The following status information is stored in the object as a property.

Stored status information can be acquired using the getter method of each property.

Printer status	Status	Description
connection:	GermanyFiscalElement.TRUE	Connected
Connection status	GermanyFiscalElement.FALSE	Disconnected

Supplementary explanation

- ❑ The status object is set to the status at the timing of execution of this API and will not be updated.
- ❑ If this function is executed within a callback function, null will be returned.

operate

Sends a JSON string to German fiscal element (TSE).

The processing result of the device using this API is notified to the listener registration method set by [setReceiveEventListener](#) of the GermanyFiscalElement class.

Syntax

```
public void operate(java.lang.String jsonString, int timeout)
throws Epos2Exception
```

Parameter

jsonString

Specifies the JSON string to send to German fiscal element (TSE).

timeout

Specifies the timeout period before completion of command transmission in milliseconds.

Value	Description
Integer from 5000 to 120000	Maximum wait time before an error is returned (in milliseconds).
PARAM_DEFAULT	Specifies the default value (10000).

Exception

When the process fails, Epos2Exception with one of the following error value occurs.

Error status	Description
ERR_PARAM	An invalid parameter was passed.
ERR_ILLEGAL	This API was called while no communication had been started.
ERR_MEMORY	Memory necessary for processing could not be allocated.
ERR_FAILURE	An unknown error occurred.
ERR_PROCESSING	Could not run the process.

Supplementary explanation

- ❑ ERR_PROCESSING occurs if this API is executed during printer processing.
Therefore, execute this API after receiving the processing complete callback.
- ❑ ERR_PARAM is returned if null is specified as the JSON string, or if the size of jsonString to be sent is 64 KByte or more.

setReceiveEventListener

Registers the listener registration method for response document receive events.

Syntax

```
public void setReceiveEventListener(ReceiveListener listener)
```

Parameter

listener

Specifies an object which has a notification target method.

Listener interface

```
public interface ReceiveListener extends EventListener
```

Listener registration method

```
void onGfeReceive (GermanyFiscalElement germanyFiscalObj,  
int code, String data)
```

Parameter

gfeObj

The callback source object is stored.

code

The processing result is stored.

Error status	Description
CODE_SUCCESS	Processed successfully.
CODE_ERR_TIMEOUT	Failed to communicate with the devices within the specified time.
CODE_ERR_PORT	An internal communication error with the device occurred.
CODE_ERR_GET_JSON_SIZE	Failed to acquire the JSON string.
CODE_ERR_AUTORECOVER	Automatic recovery error occurred.
CODE_ERR_UNRECOVERABLE	Unrecoverable error occurred.
CODE_ERR_CUTTER	Auto cutter error occurred.
CODE_ERR_MECHANICAL	Mechanical error occurred.
CODE_ERR_NOT_FOUND	The device was not found.
CODE_ERR_DEVICE_BUSY	The specified device is in process and the process cannot be executed.

data

Processing results are stored in the JSON string.

Supplementary explanation

- ❑ When this API is run multiple times, the listener registration method specified later takes effect.
- ❑ If null is specified in listener when calling this API, the registered listener registration method is canceled.
- ❑ When a communication error occurs during ePOS-Device XML control, communication disconnection is not notified.
To notify the disconnection event, implement the `setConnectionEventListener`.

OtherPeripheral class

OtherPeripheral

Initializes the OtherPeripheral class.

Syntax

```
public OtherPeripheral(Context context) throws  
Epos2Exception
```

Parameter

context

Specifies the application context.

Null can be specified when the log output function is not used.

Exception

When the process fails, Epos2Exception with one of the following error value occurs.

Error status	Description
ERR_MEMORY	Necessary memory could not be allocated.

connect

Starts communication with the peripheral device.

Syntax

```
public void connect(String target, int timeout) throws Epos2Exception
```

Parameter

target

Specifies the method of connecting to the printer by a character string.

Specify the connection method using the following syntax.

<connection type>:<identifier>[<device ID>]

I/F	Connection type	Identifier	Description
Wi-Fi/Ethernet	<ul style="list-style-type: none"> "TCP" "TCPS" 	<ul style="list-style-type: none"> IP address in IPv4 format MAC address Host name 	"TCP:192.168.192.168[local_oth er]"

To connect to the printer via SSL/TLS communication, specify TCPS in the connection type.

timeout

Specifies the maximum time (in milliseconds) to wait for communication with the printer to be established.

Value	Description
Integer from 1000 to 300000	Maximum wait time before an error is returned (in milliseconds).
Otherperipheral.PARAM_DEFAULT	Specifies the default value (15000).

Exception

When the process fails, Epos2Exception with one of the following error value occurs.

Error status	Description
ERR_PARAM	An invalid parameter was passed.
ERR_CONNECT	Failed to open the device.
ERR_TIMEOUT	Failed to communicate with the devices within the specified time.
ERR_ILLEGAL	Tried to start communication with a printer with which communication had been already established.
ERR_MEMORY	Necessary memory could not be allocated.
ERR_FAILURE	An unknown error occurred.
ERR_PROCESSING	Could not run the process.

Error status	Description
ERR_NOT_FOUND	The device could not be found.
ERR_IN_USE	The device was in use.
ERR_TYPE_INVALID	The device type is different.

Supplementary explanation

- ❑ The device ID is a logical device name that is set when the peripheral device is registered to the TM printer (master).
For details, refer to the TM-DT Series Peripheral Device Control Guide.
- ❑ When using multi-threading to connect to multiple printers or peripheral devices, this API and [disconnect](#) cannot be started for other printers or peripheral devices until this API finishes processing. Start the next process after this API finishes processing.
- ❑ Devices other than printers are exclusively locked.

disconnect

Ends communication with the peripheral device.

Syntax

```
public void disconnect() throws Epos2Exception
```

Exception

When the process fails, Epos2Exception with one of the following error value occurs.

Error status	Description
ERR_ILLEGAL	Tried to end communication where it had not been established.
ERR_MEMORY	Necessary memory could not be allocated.
ERR_FAILURE	An unknown error occurred.
ERR_PROCESSING	Could not run the process.
ERR_DISCONNECT	Failed to disconnect the device.

Supplementary explanation

When using multi-threading to connect to multiple printers or peripheral devices, this API and [connect](#) cannot be started for other printers or peripheral devices until this API finishes processing. Start the next process after this API finishes processing.

getStatus

Acquires the current status information.

Syntax

```
public OtherPeripheralStatusInfo getStatus()
```

Return value

The current status is returned in the OtherPeripheralStatusInfo type.

The following status information is stored in the object as a property.

Stored status information can be acquired using the getter method of each property.

Keyboard status	Status	Description
connection:	OtherPeripheral.TRUE	Connected
Connection status	OtherPeripheral.FALSE	Disconnected

Supplementary explanation

- ❑ The status object is set to the status at the timing of execution of this API and will not be updated.
- ❑ If this function is executed within a callback function, null will be returned.

sendData

Sends data to the peripheral device.

Specifies the arbitrary function of the device control program side, and passes JSON data made from a set of the property name and value.

For details, refer to the TM-DT Series Peripheral Device Control Guide.

The processing result of this API is notified to the listener registration method set by the [setReceiveEventListener](#) API.

Syntax

```
public void sendData(String methodName, String data) throws Epos2Exception
```

Parameter

methodName

Specifies the function name to be executed.

data

Specifies the parameter to be passed to the function in JSON string.

Exception

When the process fails, Epos2Exception with one of the following error value occurs.

Error status	Description
ERR_PARAM	An invalid parameter was passed.
ERR_CONNECT	Communication failed.
ERR_MEMORY	Sufficient memory required for processing could not be allocated.
ERR_FAILURE	An unknown error occurred.
ERR_PROCESSING	Could not run the process.
ERR_ILLEGAL	This API was called while no communication had been started.

setReceiveEventListener

Registers a listener registration method for a notification of reception data from the peripheral device event.

Syntax

```
public void setReceiveEventListener(ReceiveListener listener)
```

Parameter

listener

Specifies an object which has a notification target method.

Listener interface

```
public interface ReceiveListener extends EventListener
```

Listener registration method

```
void onOtherReceive(OtherPeripheral otherObj,  
java.lang.String eventName, String data)
```

Parameter

otherObj

The callback source object is stored.

eventName

The event name is stored.

data

Reception data is stored in the JSON string.

Supplementary explanation

- ❑ When this API is run multiple times, the listener registration method specified later takes effect.
- ❑ If null is specified in listener when calling this API, the registered listener registration method is canceled.

CommBox class

CommBox

Initializes the CommBox class.

Syntax

```
public CommBox(Context context) throws Epos2Exception
```

Parameter

context

Specifies the application context.

Null can be specified when the log output function is not used.

Exception

When the process fails, Epos2Exception with one of the following error value occurs.

Error status	Description
ERR_MEMORY	Necessary memory could not be allocated.

Supplementary explanation

When iterating a process, be sure to generate and destroy instances outside the iterated process and not iterate the process at a short interval.

Memory releasing by the OS may affect the process of the Epson ePOS SDK, resulting in an invalid operation.

connect

Starts communication with the communication box.

Syntax

```
public void connect(String target, int timeout, String myId)
throws Epos2Exception
```

Parameter

target

Specifies the method of connecting to the printer by a character string.

Specify the connection method using the following syntax.

<connection type>:<identifier>[<box ID>]

I/F	Connection type	Identifier	Example
Wi-Fi/Ethernet	<ul style="list-style-type: none"> "TCP" "TCPS" 	<ul style="list-style-type: none"> IP address in IPv4 format MAC address Host name 	"TCP:192.168.192.168[Box1]"

To connect to the printer via SSL/TLS communication, specify TCPS in the connection type.

timeout

Specifies the maximum time (in milliseconds) to wait for communication with the printer to be established.

Value	Description
Integer from 1000 to 300000	Maximum wait time before an error is returned (in milliseconds).
CommBox.PARAM_DEFAULT	Specifies the default value (15000).

myId

Specifies a member ID to identify the application itself in the communication box.

Exception

When the process fails, Epos2Exception with one of the following error value occurs.

Error status	Description
ERR_PARAM	An invalid parameter was passed.
ERR_CONNECT	Could not open the device.
ERR_TIMEOUT	Failed to communicate with the devices within the specified time.
ERR_MEMORY	Memory necessary for processing could not be allocated.
ERR_FAILURE	An unknown error occurred.

Error status	Description
ERR_PROCESSING	Could not run the process.
ERR_ALREADY_OPENED	Communication box is already open.
ERR_ALREADY_USED	Specified member ID is already in use.
ERR_BOX_COUNT_OVER	The number of created communication boxes has exceeded the upper limit.
ERR_BOX_CLIENT_OVER	The number of members belong to the communication box has exceeded the upper limit.

Supplementary explanation

- This API will succeed regardless of the connection status of the TM printer (master) and peripheral devices.
- Devices other than printers are exclusively locked.

disconnect

Ends communication with the communication box.

Syntax

```
public void disconnect() throws Epos2Exception
```

Exception

When the process fails, Epos2Exception with one of the following error value occurs.

Error status	Description
ERR_PARAM	An invalid parameter was passed.
ERR_CONNECT	Communication failed.
ERR_MEMORY	Memory necessary for processing could not be allocated.
ERR_FAILURE	An unknown error occurred.
ERR_PROCESSING	Could not run the process.

getStatus

Acquires the current status information.

Syntax

```
public CommBoxStatusInfo getStatus ()
```

Return value

The current status is returned in the CommBoxStatusInfo type.

The following status information is stored in the object as a property.

Stored status information can be acquired using the getter method of each property.

Printer status	Status	Description
connection:	CommBox.TRUE	Connected
Connection status	CommBox.FALSE	Disconnected

Supplementary explanation

- ❑ The status object is set to the status at the timing of execution of this API and will not be updated.
- ❑ If this function is executed within a callback function, null will be returned.

getCommHistory

Acquires the transmission history of the communication box.

The error status of this API is the result of sending data to the devices.

The processing result of the devices using this API is notified to the set listener registration method.

Syntax

```
public void getCommHistory(GetCommHistoryCallback
callback) throws Epos2Exception
```

Parameter

callback

Specifies an object which has a notification target method.

Exception

When the process fails, Epos2Exception with one of the following error value occurs.

Error status	Description
ERR_PARAM	An invalid parameter was passed.
ERR_CONNECT	Communication failed.
ERR_MEMORY	Memory necessary for processing could not be allocated.
ERR_FAILURE	An unknown error occurred.
ERR_PROCESSING	Could not run the process.

Listener interface

```
public interface GetCommHistoryCallback extends
EventListener
```

Definition of the listener registration method

```
void onGetCommHistory(CommBox commBoxObj, int code,
ArrayList<HashMap<String, String>> historyList
```

Parameter

commBoxObj

The callback source object is stored.

code

Error status	Description
SUCCESS	Processed successfully.
CODE_ERR_FAILURE	An unknown error occurred.

historyList

The transmission history of the communication box is stored.

historyList[index]	
Key	Description
String senderId	The member ID of the transmitter is stored. If no member ID was specified when running the connect method, "" (blank character) is set.
String receiverId	The member ID of the receiver is stored. If data was sent to all the members of the communication box, "" (blank character) is set.
String message	Received data is set.

sendMessage

Sends a message to the communication box.

The error status of this API is the result of sending data to the devices.

The processing result of the devices using this API is notified to the set listener registration method.

Syntax

```
public void sendMessage (String message, String
targetId,SendMessageCallback callback) throws
Epos2Exception
```

Parameter

message

Specifies data to send to the communication box.

targetId

Specifies the member ID of the receiver.

When null or "" (blank character) is specified, data is sent to all the members other than the transmitter.

callback

Specifies an object which has a notification target method.

Exception

When the process fails, Epos2Exception with one of the following error value occurs.

Error status	Description
ERR_PARAM	An invalid parameter was passed.
ERR_MEMORY	Memory necessary for processing could not be allocated.
ERR_FAILURE	An unknown error occurred.
ERR_PROCESSING	Could not run the process.
ERR_ILLEGAL	This API was called while no communication had been started.

Listener interface

```
public interface SendMessageCallback extends EventListener
```

Definition of the listener registration method

```
void onCommBoxSendMessage (CommBox commBoxObj,int
code, int count)
```

Parameter

commBoxObj

The callback source object is stored.

code

Error status	Description
CODE_SUCCESS	Processed successfully.
CODE_ERR_NOT_FOUND	Specified member ID cannot be found.
CODE_ERR_FAILURE	An unknown error occurred.

count

Number of clients which tried to send the message is stored.

setReceiveEventListener

Registers a listener registration method for a message reception event of the communication box.

Syntax

```
public void setReceiveEventListener (ReceiveListener listener)
```

Parameter

listener

Specifies an object which has a notification target method.

Listener interface

```
public interface ReceiveListener extends EventListener
```

Listener registration method

```
void onCommBoxReceive(CommBox commBoxObj, String senderId, String receiverId String message)
```

Parameter

commBoxObj

The callback source object is stored.

senderId

The member ID of the transmitter is stored.

If no member ID was specified when a transmitting member run the connect method, "" (blank character) is set.

receiverId

The member ID of the receiver is stored.

If data was sent to all the members of the communication box, "" (blank character) is set.

message

The received message is stored.

Supplementary explanation

- ❑ When this API is run multiple times, the listener registration method specified later takes effect.
- ❑ If null is specified in listener when calling this API, the registered listener registration method is canceled.
- ❑ When a communication error occurs during ePOS-Device XML control, communication disconnection is not notified.
To notify the disconnection event, implement the [setConnectionEventListener](#).

Common to all classes

getAdmin

Acquires the administrator name set with printer.

Syntax

```
public String getAdmin()
```

Return value

A string for the administrator name.

Supplementary explanation

- ❑ If not set, "" (blank character) is returned for the TM printer.
- ❑ The administrator name is set by EPSON TMNet WebConfig.
- ❑ This API cannot be used with *Bluetooth* communication.

getLocation

Acquires the installation location information set with printer.

Syntax

```
public String getLocation()
```

Return value

A string for the installation location.

Supplementary explanation

- ❑ If not set, "" (blank character) is returned for the TM printer.
- ❑ The installation location information is set by EPSON TMNet WebConfig.
- ❑ This API cannot be used with *Bluetooth* communication.

setConnectionEventListener

Registers a listener registration method which receives a notification that a reconnection process has been started.

Be sure to perform a process (e.g., display a message to indicate that reconnection has been started) when setConnectionEventListener is run.

Syntax

```
public void setConnectionEventListener (ConnectionListener listener)
```

Parameter

listener

Specifies an object which has a notification target method.

Listener interface

```
public interface ConnectionListener extends EventListener
```

Listener registration method

```
void onConnection(Object deviceObj, int eventType)
```

Parameter

deviceObj

The callback source object is stored.

eventType

The type of the event that occurred is stored.

Event type	Description
*.EVENT_RECONNECTING	Reconnection start event
*.EVENT_RECONNECT	Reconnection completion event
*.EVENT_DISCONNECT	Disconnection event

Supplementary explanation

- ❑ When this API is run multiple times, the listener registration method specified later takes effect.
- ❑ If null is specified in listener when calling this API, the registered listener registration method is canceled.
- ❑ It takes about 30 seconds for the disconnection event to occur after the disconnection.
- ❑ Do not make any call operation when *.EVENT_RECONNECTING has occurred.
Wait until *.EVENT_RECONNECT or *.EVENT_DISCONNECT occurs.
- ❑ *.EVENT_DISCONNECT occurs in the following cases:
 - When disconnect is running
 - When connection fails after occurrence of *.EVENT_RECONNECTING

- ❑ When *. EVENT_DISCONNECT occurs, it is not necessary to call disconnect.
When disconnect is called, an exception with ERR_ILLEGAL stored in Epos2Exception will occur.

Discovery class

start

Starts searching for the specified device type.
An event is generated for each device detected.

Syntax

```
public static synchronized void start(Context context,
    FilterOption filterOption, DiscoveryListener listener) throws
    Epos2Exception
```

Parameter

context

Sets an instance of the Context class for the caller.
Example) Sets Context acquired by `getBaseContext()` within Activity.

filterOption

In order to filter the search result, set the filter option in the FilterOption type and specify it in the parameter. When null is specified, search is run with the default settings.

The following information is stored in the FilterOption type.

portType

Selects the port to search.

Value	Description
Discovery.PORTTYPE_ALL (default)	Search for all devices which can be connected via TCP and <i>Bluetooth</i> .
Discovery.PORTTYPE_TCP	Search for devices connected to the network.
Discovery.PORTTYPE_BLUETOOTH	Search for devices which can be connected via <i>Bluetooth</i> .
Discovery.PORTTYPE_USB	Search for devices which can be connected via USB.

broadcast

Specify a Broadcast Address for TCP search as a string.

Value	Description
"255.255.255.255" (default)	-

deviceModel

Specifies the device model to search for.

Value	Description
Discovery.MODEL_ALL	Search for all models.

`epsonFilter`

Filters the search result by the Epson printers.

Value	Description
<code>Discovery.FILTER_NAME(default)</code>	Filters the search result by the Epson printers.
<code>Discovery.FILTER_NONE</code>	Does not filter the search result.

`deviceType`

Specifies the device type to search for.

Value	Description
<code>Discovery.TYPE_ALL (default)</code>	Search for all devices.
<code>Discovery.TYPE_PRINTER</code>	Search for printers.
<code>Discovery.TYPE_HYBRID_PRINTER</code>	Searches for hybrid model printers.
<code>Discovery.TYPE_DISPLAY</code>	Search for customer displays.
<code>Discovery.TYPE_KEYBOARD</code>	Search for keyboards.
<code>Discovery.TYPE_SCANNER</code>	Search for barcode scanners.
<code>Discovery.TYPE_SERIAL</code>	Search for serial communication devices.
<code>Discovery.TYPE_POS_KEYBOARD</code>	Search for the POS keyboard.
<code>Discovery.TYPE_MSR</code>	Search for the MSR.
<code>Discovery.TYPE_GFE</code>	Search for German fiscal element (TSE).
<code>Discovery.TYPE_OTHER_PERIPHERAL</code>	Search for other peripheral devices.

`bondedDevices`

Specifies the search target when searching for a device that can be connected via *Bluetooth*.

Value	Description
<code>Discovery.TRUE</code>	Search for devices that can be connected, and devices that were previously connected.
<code>Discovery.FALSE (default)</code>	Search for devices that can be connected.

listener

Specifies an object which has a notification target method.

Exception

When the process fails, `Epos2Exception` with one of the following error status occurs.

Error status	Description
<code>ERR_PARAM</code>	An invalid parameter was passed.

Error status	Description
ERR_ILLEGAL	<ul style="list-style-type: none"> • Tried to start search when search had been already done. • <i>Bluetooth</i> is OFF. • There is no permission for the position information.
ERR_MEMORY	Memory necessary for processing could not be allocated.
ERR_FAILURE	An unknown error occurred.
ERR_PROCESSING	Could not run the process.

Listener interface

public interface DiscoveryListener extends EventListener

Listener registration method

void onDiscovery(DeviceInfo deviceInfo);

Parameter

deviceInfo

The device information of the detected device is stored in the DeviceInfo type.

The following device information is stored.

deviceType

The device type is stored.

Device type	Status
For a printer	Discovery.TYPE_PRINTER
For hybrid model printers	Discovery.TYPE_HYBRID_PRINTER
For a customer display	Discovery.TYPE_DISPLAY
For a keyboard	Discovery.TYPE_KEYBOARD
For a barcode scanner	Discovery.TYPE_SCANNER
For a serial communication device	Discovery.TYPE_SERIAL
For POS keyboard	Discovery.TYPE_POS_KEYBOARD
For MSR	Discovery.TYPE_MSR
For German fiscal element (TSE)	Discovery.TYPE_GFE
For other peripheral devices	Discovery.TYPE_OTHER_PERIPHERAL

target

The connection target of a device which can be specified by connectAPI is stored as a string.

Example)

"TCP:192.168.192.168"

```
"BT:00:22:15:7D:70:9C"
"USB:/dev/udev/*"
"USB:00000000000000000000"
"TCP:192.168.192.168[local_printer]"
"TCP:192.168.192.168[local_display]"
"TCP:12:34:56:78:56:78"
```

deviceName

The name set to the device is stored.

If it could not be acquired, "" (blank character) is stored.

Example)

For a printer: "TM-T88V"

ipAddress

The IP address is stored.

If it could not be acquired, "" (blank character) is stored.

Example)

TCP: "192.168.192.168"

BT: ""(blank character)

macAddress

The MAC address is stored.

If it could not be acquired, "" (blank character) is stored.

Example)

TCP: "12:34:56:78:56:78"

BT: ""(blank character)

bdAddress

The BD address is stored.

If it could not be acquired, "" (blank character) is stored.

Example)

TCP: ""(blank character)

BT: "12:34:56:78:56:78"

Supplementary explanation

- The search result of this API is reported to the callback function for each device detected. An already opened device is also reported. However, a USB device and a *Bluetooth* device are not reported if they have been already opened.
- In search for TCP devices, if multiple devices with the same IP address exist, the device information is treated as a single device. Consistency for such device information is not guaranteed.
- If the printer has its TCP address and TCPS address, and the both are detected, only the TCPS address is reported to the callback function.
- Hybrid model printers can be detected as deviceType of `Discovery.TYPE_PRINTER` and `Discovery.TYPE_HYBRID_PRINTER`.
- To search for a hybrid model printer connected via USB, specify `Discovery.TYPE_ALL` in deviceType.
- After the search begins and the process ends, make sure to end the search.
- This search function is not available in Android Studio simulator.

stop

Stops search.

Syntax

```
public static synchronized void stop() throws Epos2Exception
```

Exception

When the process fails, Epos2Exception with one of the following error status occurs.

Error status	Description
ERR_ILLEGAL	Tried to stop a search while it had not been started.
ERR_FAILURE	An unknown error occurred.

Supplementary explanation

After the search begins and the process ends, make sure to end the search.

Epos2Exception class

getErrorStatus

Acquires the error status from the exception.

Syntax

```
public int getErrorStatus()
```

Return value

Error status defined by the API that generated the exception is returned.

Refer to [Error Status and countermeasures](#).

Log class

setLogSettings

Sets the log output function.

Syntax

```
public static void setLogSettings(Context context, int period,
    int output, String ipAddress, int port, int logSize, int logLevel)
    throws Epos2Exception
```

Parameter

context

Specifies the application context.

period

Specifies whether the log output function setting is temporary or permanent.

The configuration file is not created for temporary setting but is created for permanent setting.

Value	Description
PERIOD_TEMPORARY	Temporarily reflects the setting.
PERIOD_PERMANENT	Permanently reflects the setting.

output

Enables or disables the log output function and specifies the log output location.

Value	Description
OUTPUT_DISABLE	Disables the log output function.
OUTPUT_STORAGE	Output to the storage of the terminal.
OUTPUT_TCP	Output via TCP.

ipAddress

Specifies the IP address for TCP communication.

Specifies the IP address in the IPv4 format.

Null can be specified when the log output function is disabled or the log is output to the storage of the terminal.

port

Specifies the port number for TCP communication.

Also specifies a value within the valid range even when the log output function is disabled or the log is output to the storage of the terminal.

Value	Description
Integer from 0 to 65535	Port number

logSize

Specifies the maximum capacity of the log stored in the storage.

Also specifies a value within the valid range even when the log output function is disabled or the log is output to TCP.

Value	Description
Integer from 1 to 50	Maximum capacity of the log stored (in MB)

logLevel

Specifies the log output level.

Value	Description
LOGLEVEL_LOW	Low level

Exception

When the process fails, Epos2Exception with one of the following error status occurs.

Error status	Description
ERR_PARAM	An invalid parameter was passed.
ERR_FAILURE	An unknown error occurred.

Supplementary explanation

- ❑ To specify period for the PERIOD_PERMANENT, set the permissions for the application to access the storage.
- ❑ To specify output for the OUTPUT_STORAGE, set the permissions for the application to access the storage.
- ❑ To specify output for the OUTPUT_TCP, set the permissions for the application to access the network.

SdkVersion

Acquires the Epson ePOS SDK version.

Syntax

Getter

```
public static String getSdkVersion ()
```

Supplementary explanation

The version of SDK used can be acquired as a character string.

Example: "Ver.2.0.0"

EasySelect class

parseNFC

Analyzes NFC tags data.

Syntax

```
public ArrayList<EasySelectInfo>parseNFC(Tag tag, int
timeout)
```

Parameter

tag

Specifies NFC tag data that has been read by using Android API.

timeout

Specifies a time period (in milliseconds) to wait for the NFC tag analysis to complete.

Value	Description
Integer from 0 to 60000	Timeout for the parsing process (in milliseconds).
PARSE_NFC_TIMEOUT_DEFAULT	Specifies the default value (500).

Return value

The NFC tag analysis result is returned to the member variables of the EasySelectInfo class. When the analysis has failed, null is returned.

Supplementary explanation

- ❑ An NFC tag set to each TM printer includes the following information.

Type	Description
Slave printer (wired / wireless)	Epson's unique data such as a product name and a serial number.
Bluetooth compatible printer	NFC standard data for Bluetooth (BTSSP).

- ❑ For a slave printer, the parseNFC API starts broadcast communication and sets a MAC address of the slave printer. If no response is received from the printer until the timeout period has passed, null is returned. Make sure to enable the slave printer to communicate via the network before executing parseNFC.

parseQR

Analyzes QR tags data.

Syntax

```
public EasySelectInfo parseQR(String data)
```

Parameter

data

Specifies QR code data that has been read by using Android API.

Return value

The QR code analysis result is returned to the member variables of the EasySelectInfo class.

When the analysis has failed, null is returned.

Supplementary explanation

Create the QR code using createQR API and print it to be read.

Some printers can print the QR code on a status sheet. For details, refer to the Technical Reference Guide of the printer.

createQR

Creates QR code data that can be analyzed by parseQR.

Syntax

```
public String createQR(String printerName, int deviceType,
String macAddress)
```

Parameter

printerName

Specifies a printer name.

deviceType

Specifies a printer type.

Value	Description
Print.DEVTYPE_TCP	Slave printer (wired / wireless)
Print.DEVTYPE_BLUETOOTH	<i>Bluetooth</i> compatible printer

macAddress

Specifies a MAC address (for a slave printer), or a BD address (for a *Bluetooth* compatible printer). The following shows the address format.

Format	Description
00:11:22:33:44:55	Separate the digits by colons.
00-11-22-33-44-55	Separate the digits by hyphens.
001122334455	No separation

Return value

QR code print data is returned. Specify this data by addSymbol to print the QR code.

When creating the print data of QR code has failed, null is returned.

Supplementary explanation

To see the printer name, MAC address, and BD address, print a status sheet from the printer.

For instructions on how to print the status sheet, refer to the Technical Reference Guide of the printer.

EasySelectInfo class

deviceType

Stores printer type information.

Stored data	Description
Print.DEVTYPE_TCP	Slave printer
Print.DEVTYPE_BLUETOOTH	<i>Bluetooth</i> compatible printer

Syntax

```
int deviceType
```

printerName

Stores printer name information.

Syntax

```
String printerName
```

Supplementary explanation

If the TM printer is equipped with a UB-R04 or UB-E04 interface board, printerName acquired from an NFC tag will be returned as "" (blank).

macAddress

Stores a MAC address or a BD address.

Syntax

```
String macAddress
```

Status list

Error Status and countermeasures

Error Status	Cause	Countermeasure
ERR_PARAM	An invalid parameter was passed. <Example> A value outside the supported range was specified.	Check the value specified in the parameter.
ERR_CONNECT	Failed to communicate with the device. <Example> Failed to connect to the printer.	Run disconnect for the appropriate class and then connect to restore communication. When a connection is established via <i>Bluetooth</i> , the Android OS automatically attempts a reconnection. If this error status occurs even after 20 seconds or more have elapsed, recover the communication according to the method described above.
ERR_TIMEOUT	Failed to communicate with the devices within the specified time.	Check the timeout period. Set the timeout period to longer than the time required for printing.
ERR_MEMORY	Memory necessary for processing could not be allocated.	Close unnecessary applications.
ERR_ILLEGAL	The function was used in an illegal way. <Example> Tried to start communication with a printer with which communication had been already established.	Use the API in the correct manner.
ERR_PROCESSING	Could not run the process. <Example> The specified process could not be run because a similar process was being run by another thread.	The timing of the processes has overlapped. Re-execute the API in which the error occurred.
ERR_UNSUPPORTED	<ul style="list-style-type: none"> A model name or language not supported was specified. A print method not supported by the printer was specified. 	<ul style="list-style-type: none"> A function cannot be used if it is not supported by the specified model. Specify a print method supported by the printer.
ERR_NOT_FOUND	The specified target could not be found. <Example> The printer specified as the connection target does not exist.	Check if the connection type and/or IP address are correct.

Error Status	Cause	Countermeasure
ERR_IN_USE	The specified device is in use. <Example> The device is being used by another application.	Stop using the device from another application.
ERR_TYPE_INVALID	The device class is not correct (Printer, LineDisplay).	Check the class of the connected device and connect to it with the correct device class.
	An unsupported connection method is specified.	Check the system configuration, and specify the appropriate connection method.
ERR_DISCONNECT	Failed to disconnect from the device.	Check connection with the device.
ERR_ALREADY_OPENED	Communication box is already open.	Finish communication with the communication box.
ERR_ALREADY_USED	Specified member ID is already in use.	Specify a different member ID.
ERR_BOX_COUNT_OVER	The number of created communication boxes has exceeded the upper limit.	Delete an unnecessary communication box.
ERR_BOX_CLIENT_OVER	The number of members belong to the communication box has exceeded the upper limit.	Delete a member who is not using the communication box.
ERR_FAILURE	An unknown error occurred.	Check for a problem with the execution environment.

Callback Code and countermeasures

CallbackCode	Cause	Countermeasure
CODE_SUCCESS	Processed successfully.	-
CODE_ERR_TIMEOUT	The process exceeded the specified timeout period.	Adjust the timeout period.
CODE_ERR_NOT_FOUND	<ul style="list-style-type: none"> The connection type and/or IP address are not correct. The specified device is not connected. 	<ul style="list-style-type: none"> Check if the connection type and/or IP address are correct. Check connection with the device.
CODE_ERR_AUTORECOVER	<ul style="list-style-type: none"> Head overheat error occurred. Motor driver IC overheat error occurred. Battery overheat error occurred. 	Start the process after the device is cooled down.
	The print reference mark on the label sheet cannot be found.	Open and close the cover.
CODE_ERR_COVER_OPEN	<ul style="list-style-type: none"> Cover is open. Cover was opened during MICR read operation. 	Close the printer cover.
CODE_ERR_CUTTER	Auto cutter error occurred.	Remove the error cause and power off and then on the printer.
CODE_ERR_MECHANICAL	Mechanical error occurred.	Remove the error cause and power off and then on the printer.
CODE_ERR_EMPTY	Paper has run out.	Refill the paper.
CODE_ERR_UNRECOVERABLE	Unrecoverable error occurred.	Power off and then on the printer. Contact the distributor or service center if the problem persists.
CODE_ERR_SYSTEM	An error occurred with the TM-i firmware or TM-DT software.	Turn off and then turn on the power supply to the TM-i series/TM-DT series, and restart the OS.
CODE_ERR_PORT	<ul style="list-style-type: none"> Forced transmission was run in the online state. A communication error occurred. 	<ul style="list-style-type: none"> Run forced transmission in the offline state. Review the connection environment.
CODE_ERR_INVALID_WINDOW	An unregistered window was specified.	Check the specified window.
CODE_ERR_JOB_NOT_FOUND	A print job ID which did not exist was specified.	Check the specified job ID.
CODE_PRINTING	requestPrintJobStatus was run by specifying a print job ID which was being printed.	Run the process after printing completes.
CODE_ERR_SPOOLER	Print data exceeding the spooler capacity was transmitted.	Check if communication with the printer is disconnected.
CODE_ERR_BATTERY_LOW	Battery has run out.	Replace the battery or connect the AC adapter.

CallbackCode	Cause	Countermeasure
CODE_ERR_FAILURE	An unknown error occurred.	Check for a problem with the execution environment.
CODE_ERR_TOO_MANY_REQUESTS	The number of print jobs or data to be displayed on a display has exceeded the allowable limit of the printer's firmware.	Wait for the printer to process some of the tasks, then send the jobs or data again.
CODE_ERR_REQUEST_ENTITY_TOO_LARGE	Print job data with the size exceeding the capacity of the printer firmware was transmitted.	Check the content of the print job, reduce the size of the data, and then resend the print job.
CODE_ERR_NO_MICR_DATA	MICR data cannot be detected.	Check the slip sheet and clean the MICR mechanism if necessary.
CODE_ERR_ILLEGAL_LENGTH	Paper length is not appropriate.	Check the paper length.
CODE_ERR_NO_MAGNETIC_DATA	Magnetic waveform cannot be detected.	<ul style="list-style-type: none"> • Check the font to read. • Clean the MICR mechanism.
CODE_ERR_RECOGNITION	Illegible MICR text was detected.	Check the status of the slip sheet.
CODE_ERR_READ	Error occurred during MICR read operation.	Remove the error cause and try again. If the error persists, restart the printer.
CODE_ERR_NOISE_DETECTED	Noise error was detected.	Remove the error cause and try the noise measurement again. If the error persists, restart the printer.
CODE_ERR_PAPER_JAM	Paper jam error occurred during MICR read operation.	Remove the jammed paper.
CODE_ERR_PAPER_PULLED_OUT	<ul style="list-style-type: none"> • Paper was removed during insertion. • Paper was removed during MICR read operation. • Paper was removed after it had been inserted. 	Reset the paper.
CODE_ERR_CANCEL_FAILED	Failed to cancel waiting for paper insertion.	Check the status of the printer and try the process again.
CODE_ERR_PAPER_TYPE	Printer operation differs from the specified print method.	Specify a correct print method again.
CODE_ERR_WAIT_INSERTION	Could not run the process while waiting for paper insertion.	<ul style="list-style-type: none"> • Reset the paper and try the process again. • Cancel waiting for paper insertion and try the process again.
CODE_ERR_ILLEGAL	The function was used in an illegal way. <Example> Tried to cancel waiting for paper insertion while paper had already been inserted.	Use the API in an appropriate manner.
CODE_ERR_INSERTED	Could not run the process while paper had already been inserted.	Eject the paper and try the process again.
CODE_ERR_WAIT_REMOVAL	Could not run the process while waiting for paper removal.	Remove the paper and try the process again.

CallbackCode	Cause	Countermeasure
CODE_ERR_DEVICE_BUSY	The specified device is in process.	Execute the process after the process completes.

Printer Status and countermeasures

Printer class

Printer Status	Cause	Countermeasure
status.connection==Printer.FALSE	<ul style="list-style-type: none"> The printer is powered off. No connection is established with the printer. 	Check the power and communication status of the printer.
status.online==Printer.FALSE	Offline status.	Remove a cause which forces the printer offline (e.g., the cover is open or paper has run out).
status.online==Printer.UNKNOWN	No connection is established with the printer.	Check the communication status of the printer.
status.coverOpen==Printer.TRUE	Cover is open.	Close the printer cover.
status.coverOpen==Printer.UNKNOWN	No connection is established with the printer.	Check the communication status of the printer.
status.paper==Printer.PAPER_NEAR_END	Running short of paper.	Replace the paper.
status.paper==Printer.PAPER_EMPTY	Paper has run out.	Refill the paper.
status.paper==Printer.UNKNOWN	No connection is established with the printer.	Check the communication status of the printer.
status.paperFeed==Printer.TRUE	Paper is being fed by pressing the Paper Feed button.	Run the process after paper feed completes.
status.paperFeed==Printer.UNKNOWN	No connection is established with the printer.	Check the communication status of the printer.
status.panelSwitch==Printer.SWITCH_ON	Panel switch is being operated.	Run the process after the operation completes.
status.panelSwitch==Printer.UNKNOWN	No connection is established with the printer.	Check the communication status of the printer.
status.drawer==Printer.UNKNOWN	No connection is established with the printer.	Check the communication status of the printer.
status.errorStatus==Printer.MECHANICAL_ERR	Mechanical error occurred.	Remove the error cause and power off and then on the printer.
status.errorStatus==Printer.AUTOCUTTER_ERR	Auto cutter error occurred.	Remove the error cause and power off and then on the printer.
status.errorStatus==Printer.UNRECOVER_ERR	Unrecoverable error occurred.	Power off and then on the printer. Contact the distributor or service center if the problem persists.

Printer Status	Cause	Countermeasure
status.errorStatus== Printer.AUTORECOVER_ERR	<ul style="list-style-type: none"> Head overheat error occurred. Motor driver IC overheat error occurred. Battery overheat error occurred. 	Start the process after the device is cooled down.
	The print reference mark on the label sheet cannot be found.	Open and close the cover.
status.errorStatus==Printer.UNKNOWN	No connection is established with the printer.	Check the communication status of the printer.
status.autoRecoverError== Printer.HEAD_OVERHEAT	Head overheat error occurred.	Run the process after the device gets cooled down.
status.autoRecoverError== Printer.MOTOR_OVERHEAT	Motor driver IC overheat error occurred.	Run the process after the device gets cooled down.
status.autoRecoverError== Printer.BATTERY_OVERHEAT	Battery overheat error occurred.	Run the process after the device gets cooled down.
status.autoRecoverError== Printer.WRONG_PAPER	The print reference mark on the label sheet cannot be found.	Open and close the cover.
status.autoRecoverError== Printer.COVER_OPEN	Cover is open.	Close the printer cover.
status.autoRecoverError== Printer.UNKNOWN	No connection is established with the printer.	Check the communication status of the printer.
status.buzzer==Printer.TRUE	Buzzer is sounding.	Check the buzzer sounding condition of the printer, and run the process after removing the cause for buzzer sounding.
status.buzzer==Printer.UNKNOWN	No connection is established with the printer.	Check the communication status of the printer.
status.adapter==Printer.UNKNOWN	No connection is established with the printer.	Check the communication status of the printer.
status.batteryLevel== Printer.BATTERY_LEVEL_1	Running short of battery.	Charge the battery or connect the AC adapter.
status.batteryLevel== Printer.BATTERY_LEVEL_0	Battery has run out.	Replace the battery or connect the AC adapter.
status.batteryLevel==Printer.UNKNOWN	No connection is established with the printer.	Check the communication status of the printer.

HybridPrinter class

Printer Status	Cause	Countermeasure
status.connection==HybridPrinter.FALSE	<ul style="list-style-type: none"> The printer is powered off. No connection is established with the printer. 	Check the power and communication status of the printer.

Printer Status	Cause	Countermeasure
status.online==HybridPrinter.FALSE	Offline status.	Remove a cause which forces the printer offline (e.g., the cover is open or paper has run out).
status.online==HybridPrinter.UNKNOWN	No connection is established with the printer.	Check the communication status of the printer.
status.coverOpen==HybridPrinter.TRUE	Cover is open.	Close the printer cover.
status.coverOpen==HybridPrinter.UNKNOWN	No connection is established with the printer.	Check the communication status of the printer.
status.paper==HybridPrinter.PAPER_NEAR_END	Running short of paper.	Replace the paper.
status.paper==HybridPrinter.PAPER_EMPTY	Paper has run out.	Refill the paper.
status.paper==HybridPrinter.UNKNOWN	No connection is established with the printer.	Check the communication status of the printer.
status.paperFeed==HybridPrinter.TRUE	Paper is being fed by pressing the Paper Feed button.	Run the process after paper feed completes.
status.paperFeed==HybridPrinter.UNKNOWN	No connection is established with the printer.	Check the communication status of the printer.
status.panelSwitch==HybridPrinter.SWITCH_ON	Panel switch is being operated.	Run the process after the operation completes.
status.panelSwitch==HybridPrinter.UNKNOWN	No connection is established with the printer.	Check the communication status of the printer.
status.drawer==HybridPrinter.UNKNOWN	No connection is established with the printer.	Check the communication status of the printer.
status.errorStatus==HybridPrinter.MECHANICAL_ERR	Mechanical error occurred.	Remove the error cause and power off and then on the printer.
status.errorStatus==HybridPrinter.AUTOCUTTER_ERR	Auto cutter error occurred.	Remove the error cause and power off and then on the printer.
status.errorStatus==HybridPrinter.UNRECOVER_ERR	Unrecoverable error occurred.	Power off and then on the printer. Contact the distributor or service center if the problem persists.
status.errorStatus==HybridPrinter.AUTORECOVER_ERR	<ul style="list-style-type: none"> • Head overheat error occurred. • Motor driver IC overheat error occurred. 	Start the process after the device is cooled down.
status.errorStatus==HybridPrinter.UNKNOWN	No connection is established with the printer.	Check the communication status of the printer.
status.autoRecoverError==HybridPrinter.HEAD_OVERHEAT	Head overheat error occurred.	Run the process after the device gets cooled down.
status.autoRecoverError==HybridPrinter.MOTOR_OVERHEAT	Motor driver IC overheat error occurred	Run the process after the device gets cooled down.
status.autoRecoverError==HybridPrinter.WRONG_PAPER	The print reference mark on the label sheet cannot be found.	Open and close the cover.

Printer Status	Cause	Countermeasure
status.autoRecoverError== HybridPrinter.COVER_OPEN	Cover is open.	Close the printer cover.
status.autoRecoverError== HybridPrinter.UNKNOWN	No connection is established with the printer.	Check the communication status of the printer.
status.insertionWaiting== HybridPrinter.INSERTION_WAIT_SLIP	Waiting for slip sheet insertion.	Insert a slip sheet.
status.insertionWaiting== HybridPrinter.INSERTION_WAIT_VALIDATION	Waiting for validation sheet insertion.	Insert a validation sheet.
status.insertionWaiting== HybridPrinter.INSERTION_WAIT_MICR	Waiting for slip sheet insertion for MICR reading.	Insert a slip sheet.
status.insertionWaiting== HybridPrinter.UNKNOWN	No connection is established with the printer.	Check the communication status of the printer.
status.removalWaiting== HybridPrinter.REMOVAL_WAIT_PAPER	Waiting for paper removal.	Remove the paper.
status.removalWaiting== HybridPrinter.UNKNOWN	No connection is established with the printer.	Check the communication status of the printer.
status.slipPaper==EPOS2_UNKNOWN	No connection is established with the printer.	Check the communication status of the printer.

Key code list

Constant	Code	Constant	Code
Keyboard.VK_BACK	0x08	Keyboard.VK_L	0x4C
Keyboard.VK_TAB	0x09	Keyboard.VK_M	0x4D
Keyboard.VK_RETURN	0x0D	Keyboard.VK_N	0x4E
Keyboard.VK_SHIFT	0x10	Keyboard.VK_O	0x4F
Keyboard.VK_CONTROL	0x11	Keyboard.VK_P	0x50
Keyboard.VK_MENU	0x12	Keyboard.VK_Q	0x51
Keyboard.VK_CAPITAL	0x14	Keyboard.VK_R	0x52
Keyboard.VK_ESCAPE	0x1B	Keyboard.VK_S	0x53
Keyboard.VK_CONVERT	0x1C	Keyboard.VK_T	0x54
Keyboard.VK_NONCONVERT	0x1D	Keyboard.VK_U	0x55
Keyboard.VK_SPACE	0x20	Keyboard.VK_V	0x56
Keyboard.VK_PRIOR	0x21	Keyboard.VK_W	0x57
Keyboard.VK_NEXT	0x22	Keyboard.VK_X	0x58
Keyboard.VK_END	0x23	Keyboard.VK_Y	0x59
Keyboard.VK_HOME	0x24	Keyboard.VK_Z	0x5A
Keyboard.VK_LEFT	0x25	Keyboard.VK_MULTIPLY	0x6A
Keyboard.VK_UP	0x26	Keyboard.VK_ADD	0x6B
Keyboard.VK_RIGHT	0x27	Keyboard.VK_SUBTRACT	0x6D
Keyboard.VK_DOWN	0x28	Keyboard.VK_F1	0x70
Keyboard.VK_INSERT	0x2D	Keyboard.VK_F2	0x71
Keyboard.VK_DELETE	0x2E	Keyboard.VK_F3	0x72
Keyboard.VK_0	0x30	Keyboard.VK_F4	0x73
Keyboard.VK_1	0x31	Keyboard.VK_F5	0x74
Keyboard.VK_2	0x32	Keyboard.VK_F6	0x75
Keyboard.VK_3	0x33	Keyboard.VK_F7	0x76
Keyboard.VK_4	0x34	Keyboard.VK_F8	0x77
Keyboard.VK_5	0x35	Keyboard.VK_F9	0x78
Keyboard.VK_6	0x36	Keyboard.VK_F10	0x79
Keyboard.VK_7	0x37	Keyboard.VK_F11	0x7A
Keyboard.VK_8	0x38	Keyboard.VK_F12	0x7B
Keyboard.VK_9	0x39	Keyboard.VK_OEM_1	0xBA
Keyboard.VK_A	0x41	Keyboard.VK_OEM_PLUS	0xBB
Keyboard.VK_B	0x42	Keyboard.VK_OEM_COMMA	0xBC

Constant	Code	Constant	Code
Keyboard.VK_C	0x43	Keyboard.VK_OEM_MINUS	0xBD
Keyboard.VK_D	0x44	Keyboard.VK_OEM_PERIOD	0xBE
Keyboard.VK_E	0x45	Keyboard.VK_OEM_2	0xBF
Keyboard.VK_F	0x46	Keyboard.VK_OEM_3	0xC0
Keyboard.VK_G	0x47	Keyboard.VK_OEM_4	0xDB
Keyboard.VK_H	0x48	Keyboard.VK_OEM_5	0xDC
Keyboard.VK_I	0x49	Keyboard.VK_OEM_6	0xDD
Keyboard.VK_J	0x4A	Keyboard.VK_OEM_7	0xDE
Keyboard.VK_K	0x4B	Keyboard.VK_OEM_ATTN	0xF0

Device Specifications

Provides information about restriction on the use of APIs depend on devices such as printer and peripheral device, and the parameter setting value.

	Refer to the Technical Reference Guide of each printer for more information on each printer.
---	--

List of Supported Classes

The following lists the classes supported by each printer.

	Printer class ^{*1}	HybridPrinter class ^{*1}	LineDisplay class ^{*1}	Keyboard class	POSKeyboard class	BarcodeScanner class	MSR class	SimpleSerial class	GermanyFiscalElement class	OtherPeripheral class	CommBox class	Common to all classes	Discovery class	Epos2Exception class	Log class	EasySelect class ^{*1}	EasySelectInfo class
TM-m10	✓	-	-	-	-	-	-	-	-	-	-	✓	✓	✓	✓	✓	✓
TM-m30	✓	-	✓	-	-	✓ ^{*3}	-	-	✓ ^{*7}	-	-	✓	✓	✓	✓	✓	✓
TM-m30II	✓	-	✓	-	-	✓	-	-	✓	-	-	✓	✓	✓	✓	✓	✓
TM-m30II-H	✓	-	✓	-	-	✓	-	-	✓	-	-	✓	✓	✓	✓	✓	✓
TM-T20	✓	-	-	-	-	-	-	-	-	-	-	✓	✓	✓	✓	✓	✓
TM-T20II	✓	-	-	-	-	-	-	-	-	-	-	✓	✓	✓	✓	✓	✓
TM-T20III	✓	-	-	-	-	-	-	-	-	-	-	✓	✓	✓	✓	✓	✓
TM-T20IIIL	✓	-	-	-	-	-	-	-	-	-	-	✓	✓	✓	✓	✓	✓
TM-T20X	✓	-	-	-	-	-	-	-	-	-	-	✓	✓	✓	✓	✓	✓
TM-T60	✓	-	-	-	-	-	-	-	-	-	-	✓	✓	✓	✓	✓	✓
TM-T70	✓	-	-	-	-	-	-	-	-	-	-	✓	✓	✓	✓	✓	✓
TM-T70II	✓	-	-	-	-	-	-	-	-	-	-	✓	✓	✓	✓	✓	✓
TM-T81II	✓	-	-	-	-	-	-	-	-	-	-	✓	✓	✓	✓	✓	✓
TM-T81III	✓	-	-	-	-	-	-	-	-	-	-	✓	✓	✓	✓	✓	✓
TM-T82	✓	-	-	-	-	-	-	-	-	-	-	✓	✓	✓	✓	✓	✓
TM-T82II	✓	-	-	-	-	-	-	-	-	-	-	✓	✓	✓	✓	✓	✓
TM-T82III	✓	-	-	-	-	-	-	-	-	-	-	✓	✓	✓	✓	✓	✓
TM-T82IIIL	✓	-	-	-	-	-	-	-	-	-	-	✓	✓	✓	✓	✓	✓
TM-T82X	✓	-	-	-	-	-	-	-	-	-	-	✓	✓	✓	✓	✓	✓
TM-T83II	✓	-	-	-	-	-	-	-	-	-	-	✓	✓	✓	✓	✓	✓

	Printer class ^{*1}	HybridPrinter class ^{*1}	LineDisplay class ^{*1}	Keyboard class	POSKeyboard class	BarcodeScanner class	MSR class	SimpleSerial class	GermanyFiscalElement class	OtherPeripheral class	CommBox class	Common to all classes	Discovery class	Epos2Exception class	Log class	EasySelect class ^{*1}	EasySelectInfo class
TM-T83III	✓	-	-	-	-	-	-	-	-	-	-	✓	✓	✓	✓	✓	✓
TM-T88V	✓	-	-	-	-	-	-	-	-	-	-	✓	✓	✓	✓	✓	✓
TM-T88VI	✓	-	✓	-	-	✓ ^{*4}	-	-	-	-	-	✓	✓	✓	✓	✓	✓
TM-T100	✓	-	-	-	-	-	-	-	-	-	-	✓	✓	✓	✓	✓	✓
TM-U220	✓	-	-	-	-	-	-	-	-	-	-	✓	✓	✓	✓	✓	✓
TM-U330	✓	-	-	-	-	-	-	-	-	-	-	✓	✓	✓	✓	✓	✓
TM-P20	✓	-	-	-	-	-	-	-	-	-	-	✓	✓	✓	✓	✓	✓
TM-P60 (Receipt)	✓	-	-	-	-	-	-	-	-	-	-	✓	✓	✓	✓	✓	✓
TM-P60 (Peeler)	✓	-	-	-	-	-	-	-	-	-	-	✓	✓	✓	✓	✓	✓
TM-P60II (Receipt)	✓	-	-	-	-	-	-	-	-	-	-	✓	✓	✓	✓	✓	✓
TM-P60II (Peeler)	✓	-	-	-	-	-	-	-	-	-	-	✓	✓	✓	✓	✓	✓
TM-P80	✓	-	-	-	-	-	-	-	-	-	-	✓	✓	✓	✓	✓	✓
TM-H6000V	✓	✓ ^{*5}	✓	-	-	-	-	-	-	-	-	✓	✓	✓	✓	✓	✓
TM-T20II-i	✓	-	✓	✓	-	✓ ^{*6}	✓ ^{*6}	✓	-	-	✓	✓	✓	✓	✓	-	-
TM-T70-i	✓	-	✓	✓	-	✓ ^{*6}	✓ ^{*6}	✓	-	-	✓	✓	✓	✓	✓	-	-
TM-T82II-i	✓	-	✓	✓	-	✓ ^{*6}	✓ ^{*6}	✓	-	-	✓	✓	✓	✓	✓	-	-
TM-T83II-i	✓	-	✓	✓	-	✓ ^{*6}	✓ ^{*6}	✓	-	-	✓	✓	✓	✓	✓	-	-
TM-T88V-i	✓	-	✓	✓	-	✓ ^{*6}	✓ ^{*6}	✓	-	-	✓	✓	✓	✓	✓	-	-
TM-T88VI-iHUB	✓	-	✓	✓	-	✓ ^{*6}	✓ ^{*6}	✓	✓ ^{*7}	-	✓	✓	✓	✓	✓	-	-
TM-U220-i	✓	-	✓	✓	-	✓ ^{*6}	✓ ^{*6}	✓	-	-	✓	✓	✓	✓	✓	-	-
TM-T70II-DT	✓	-	✓	✓	✓	✓	✓	✓	-	✓	✓	✓	✓	✓	✓	-	-
TM-T70II-DT2	✓	-	✓	✓	✓	✓	✓	✓	-	✓	✓	✓	✓	✓	✓	-	-
TM-T88V-DT	✓	-	✓	✓	✓	✓	✓	✓	-	✓	✓	✓	✓	✓	✓	-	-
TM-T88VI-DT2	✓	-	✓	✓	✓	✓	✓	✓	-	✓	✓	✓	✓	✓	✓	-	-
TM-H6000IV-DT	✓	-	✓	✓	✓	✓	✓	✓	-	✓	✓	✓	✓	✓	✓	-	-
TM-T88IV ^{*2}	✓	-	-	-	-	-	-	-	-	-	-	-	-	-	-	-	-
TM-T90 ^{*2}	✓	-	-	-	-	-	-	-	-	-	-	-	-	-	-	-	-
TM-L90 ^{*2}	✓	-	-	-	-	-	-	-	-	-	-	-	-	-	-	-	-
TM-H6000IV ^{*2}	✓	-	-	-	-	-	-	-	-	-	-	-	-	-	-	-	-

*1: The availability and restriction on the use of APIs varies for each printer. Refer to [List of Supported APIs](#).

*2: Supports control as a slave printer only.

*3: Supported by TM-m30 firmware Ver. 1.40 ESC/POS or later.

*4: Supported by TM-T88VI firmware Ver. 40.50 ESC/POS or later.

*5: The availability and restriction on the use of APIs varies for each model. Refer to [HybridPrinter class](#).

*6: Does not support control by the device control program.

*7: Supported with the following versions of firmware.

- TM-m30 firmware Ver. 1.46A ESC/POS or later
- TM-m30 firmware Ver. 1.46B ESC/POS or later
- TM-T88VI-iHUB firmware Ver. 50.52A ESC/POS or later
- TM-T88VI-iHUB firmware Ver. 50.52B ESC/POS or later

List of Supported APIs

Provides list of supported APIs for each printer.

The following is an explanation of the symbol indicated in table:

- ✓: Supported.
- ✓*: Supported but has a restriction on specifying the parameter setting value.
- -: Not supported.

For information on the "✓*" restrictions, refer to Printer-specific Support Information.

Printer class

Single-function models (1)

API	TM-m10	TM-m30	TM-m30II	TM-m30II-H	TM-T20	TM-T20II	TM-T20III	TM-T20III-L	TM-T20X	TM-T60	TM-T70	TM-T70II	TM-T81II	TM-T81III	TM-T82
Printer	✓*	✓*	✓*	✓*	✓*	✓*	✓*	✓*	✓*	✓*	✓*	✓*	✓*	✓*	✓*
connect	✓	✓	✓	✓	✓	✓	✓	✓	✓	✓	✓	✓	✓	✓	✓
disconnect	✓	✓	✓	✓	✓	✓	✓	✓	✓	✓	✓	✓	✓	✓	✓
startMonitor	✓	✓	✓	✓	✓	✓	✓	✓	✓	✓	✓	✓	✓	✓	✓
stopMonitor	✓	✓	✓	✓	✓	✓	✓	✓	✓	✓	✓	✓	✓	✓	✓
getStatus	✓	✓	✓	✓	✓	✓	✓	✓	✓	✓	✓	✓	✓	✓	✓
sendData	✓	✓	✓	✓	✓	✓	✓	✓	✓	✓	✓	✓	✓	✓	✓
beginTransaction	✓	✓	✓	✓	-	-	-	-	-	-	-	-	-	-	-
endTransaction	✓	✓	✓	✓	-	-	-	-	-	-	-	-	-	-	-
requestPrintJobStatus	-	-	-	-	-	-	-	-	-	-	-	-	-	-	-
clearCommandBuffer	✓	✓	✓	✓	✓	✓	✓	✓	✓	✓	✓	✓	✓	✓	✓
addTextAlign	✓	✓	✓	✓	✓	✓	✓	✓	✓	✓	✓	✓	✓	✓	✓
addLineSpace	✓	✓	✓	✓	✓	✓	✓	✓	✓	✓	✓	✓	✓	✓	✓
addTextRotate	✓	✓	✓	✓	✓	✓	✓	✓	✓	✓	✓	✓	✓	✓	✓
addText	✓	✓	✓	✓	✓	✓	✓	✓	✓	✓	✓	✓	✓	✓	✓
addTextLang	✓*	✓*	✓*	✓	✓*	✓*	✓*	✓*	✓*	✓*	✓*	✓*	✓*	✓*	✓*
addTextFont	✓*	✓*	✓*	✓*	✓*	✓*	✓*	✓*	✓*	✓*	✓*	✓*	✓*	✓*	✓*
addTextSmooth	✓	✓	✓	✓	✓	✓	✓	✓	✓	✓	✓	✓	✓	✓	✓
addTextSize	✓	✓	✓	✓	✓	✓	✓	✓	✓	✓	✓	✓	✓	✓	✓
addTextStyle	✓*	✓*	✓*	✓*	✓*	✓*	✓*	✓*	✓*	✓*	✓*	✓*	✓*	✓*	✓*
addHPosition	✓	✓	✓	✓	✓	✓	✓	✓	✓	✓	✓	✓	✓	✓	✓
addFeedUnit	✓	✓	✓	✓	✓	✓	✓	✓	✓	✓	✓	✓	✓	✓	✓

API	TM-m10	TM-m30	TM-m30II	TM-m30II-H	TM-T20	TM-T20II	TM-T20III	TM-T20III-L	TM-T20X	TM-T60	TM-T70	TM-T70II	TM-T81II	TM-T81III	TM-T82
addFeedLine	✓	✓	✓	✓	✓	✓	✓	✓	✓	✓	✓	✓	✓	✓	✓
addImage	✓*	✓*	✓*	✓*	✓*	✓*	✓*	✓*	✓*	✓*	✓*	✓*	✓*	✓*	✓*
addLogo	✓	✓	✓	✓	✓	✓	✓	✓	✓	✓	✓	✓	✓	✓	✓
addBarcode	✓*	✓*	✓*	✓*	✓*	✓*	✓*	✓*	✓*	✓*	✓*	✓*	✓*	✓*	✓*
addSymbol	✓*	✓*	✓*	✓*	✓*	✓*	✓*	✓*	✓*	✓*	✓*	✓*	✓*	✓*	✓*
addHLine	-	-	-	-	-	-	-	-	-	-	-	-	-	-	-
addVLineBegin	-	-	-	-	-	-	-	-	-	-	-	-	-	-	-
addVLineEnd	-	-	-	-	-	-	-	-	-	-	-	-	-	-	-
addPageBegin	✓	✓	✓	✓	✓	✓	✓	✓	✓	✓	✓	✓	✓	✓	✓
addPageEnd	✓	✓	✓	✓	✓	✓	✓	✓	✓	✓	✓	✓	✓	✓	✓
addPageArea	✓	✓	✓	✓	✓	✓	✓	✓	✓	✓	✓	✓	✓	✓	✓
addPageDirection	✓	✓	✓	✓	✓	✓	✓	✓	✓	✓	✓	✓	✓	✓	✓
addPagePosition	✓	✓	✓	✓	✓	✓	✓	✓	✓	✓	✓	✓	✓	✓	✓
addPageLine	✓*	✓*	✓*	✓*	-	-	-	-	-	-	-	-	-	-	-
addPageRectangle	✓*	✓*	✓*	✓*	-	-	-	-	-	-	-	-	-	-	-
addRotateBegin	-	-	✓	✓	-	-	-	-	-	-	-	-	-	-	-
addRotateEnd	-	-	✓	✓	-	-	-	-	-	-	-	-	-	-	-
addCut	✓*	✓*	✓*	✓*	✓*	✓*	✓*	✓*	✓*	✓*	✓*	✓*	✓*	✓*	✓*
addPulse	✓	✓	✓	✓	✓	✓	✓	✓	✓	✓	✓	✓	✓	✓	✓
addSound	✓*	✓*	✓*	✓*	✓*	✓*	✓*	✓*	✓*	-	-	✓*	-	✓*	✓*
addFeedPosition	-	-	-	-	-	-	-	-	-	-	-	-	-	-	-
addLayout	-	-	-	-	-	-	-	-	-	-	-	-	-	-	-
addCommand	✓	✓	✓	✓	✓	✓	✓	✓	✓	✓	✓	✓	✓	✓	✓
getMaintenanceCounter	-	✓	✓	✓	-	✓	-	-	-	-	-	-	-	-	-
resetMaintenanceCounter	-	✓	✓	✓	-	✓	-	-	-	-	-	-	-	-	-
getPrinterSetting	-	✓*	✓*	✓*	-	✓*	-	-	-	-	-	-	-	-	-
setPrinterSetting	-	✓*	✓*	✓*	-	✓*	-	-	-	-	-	-	-	-	-
downloadFirmwareList	✓*	✓*	-	-	-	-	-	-	-	-	-	-	-	-	-
getPrinterFirmwareInfo	✓	✓	-	-	-	-	-	-	-	-	-	-	-	-	-
verifyUpdate	✓	✓	-	-	-	-	-	-	-	-	-	-	-	-	-
updateFirmware	✓	✓	-	-	-	-	-	-	-	-	-	-	-	-	-
forceRecover	-	-	-	-	-	-	-	-	-	-	-	-	-	-	-
forcePulse	-	-	-	-	-	-	-	-	-	-	-	-	-	-	-

API	TM-m10	TM-m30	TM-m30II	TM-m30II-H	TM-T20	TM-T20II	TM-T20III	TM-T20IIIL	TM-T20X	TM-T60	TM-T70	TM-T70II	TM-T81II	TM-T81III	TM-T82
forceStopSound	-	-	-	-	-	-	-	-	-	-	-	-	-	-	-
forceCommand	-	-	-	-	-	-	-	-	-	-	-	-	-	-	-
forceReset	-	-	-	-	-	-	-	-	-	-	-	-	-	-	-
setStatusChangeListener	✓	✓	✓	✓	✓	✓	✓	✓	✓	✓	✓	✓	✓	✓	✓
setReceiveEventListener	✓	✓	✓	✓	✓	✓	✓	✓	✓	✓	✓	✓	✓	✓	✓
interval	✓	✓	✓	✓	✓	✓	✓	✓	✓	✓	✓	✓	✓	✓	✓

Single-function models (2)

API	TM-T82II	TM-T82III	TM-T82IIIL	TM-T82X	TM-T83II	TM-T83III	TM-T88V	TM-T88VI	TM-T100	TM-U220	TM-U330
Printer	✓*	✓*	✓*	✓*	✓*	✓*	✓*	✓*	✓*	✓*	✓*
connect	✓	✓	✓	✓	✓	✓	✓	✓	✓	✓	✓
disconnect	✓	✓	✓	✓	✓	✓	✓	✓	✓	✓	✓
startMonitor	✓	✓	✓	✓	✓	✓	✓	✓	✓	✓	✓
stopMonitor	✓	✓	✓	✓	✓	✓	✓	✓	✓	✓	✓
getStatus	✓	✓	✓	✓	✓	✓	✓	✓	✓	✓	✓
sendData	✓	✓	✓	✓	✓	✓	✓	✓	✓	✓	✓
beginTransaction	-	-	-	-	-	-	-	✓	-	-	-
endTransaction	-	-	-	-	-	-	-	✓	-	-	-
requestPrintJobStatus	-	-	-	-	-	-	-	-	-	-	-
clearCommandBuffer	✓	✓	✓	✓	✓	✓	✓	✓	✓	✓	✓
addTextAlign	✓	✓	✓	✓	✓	✓	✓	✓	✓	✓	✓
addLineSpace	✓	✓	✓	✓	✓	✓	✓	✓	✓	✓	✓
addTextRotate	✓	✓	✓	✓	✓	✓	✓	✓	✓	✓	✓
addText	✓	✓	✓	✓	✓	✓	✓	✓	✓	✓	✓
addTextLang	✓*	✓*	✓*	✓*	✓*	✓*	✓*	✓*	✓*	✓*	✓*
addTextFont	✓*	✓*	✓*	✓*	✓*	✓*	✓*	✓*	✓*	✓*	✓*
addTextSmooth	✓	✓	✓	✓	✓	✓	✓	✓	✓	✓	✓
addTextSize	✓	✓	✓	✓	✓	✓	✓	✓	✓	✓	✓
addTextStyle	✓*	✓*	✓*	✓*	✓*	✓*	✓*	✓*	✓*	✓*	✓*
addHPosition	✓	✓	✓	✓	✓	✓	✓	✓	-	-	✓
addFeedUnit	✓	✓	✓	✓	✓	✓	✓	✓	✓	✓	✓

API	TM-T82II	TM-T82III	TM-T82IIIL	TM-T82X	TM-T83II	TM-T83III	TM-T88V	TM-T88VI	TM-T100	TM-U220	TM-U330
addFeedLine	✓	✓	✓	✓	✓	✓	✓	✓	✓	✓	✓
addImage	✓*	✓*	✓*	✓*	✓*	✓*	✓*	✓*	✓*	✓*	✓*
addLogo	✓	✓	✓	✓	✓	✓	✓	✓	✓	✓*	✓*
addBarcode	✓*	✓*	✓*	✓*	✓*	✓*	✓*	✓*	✓*	-	✓*
addSymbol	✓*	✓*	✓*	✓*	✓*	✓*	✓*	✓*	✓*	-	✓*
addHLine	-	-	-	-	-	-	-	-	-	-	-
addVLineBegin	-	-	-	-	-	-	-	-	-	-	-
addVLineEnd	-	-	-	-	-	-	-	-	-	-	-
addPageBegin	✓	✓	✓	✓	✓	✓	✓	✓	✓	-	-
addPageEnd	✓	✓	✓	✓	✓	✓	✓	✓	✓	-	-
addPageArea	✓	✓	✓	✓	✓	✓	✓	✓	✓	-	-
addPageDirection	✓	✓	✓	✓	✓	✓	✓	✓	✓	-	-
addPagePosition	✓	✓	✓	✓	✓	✓	✓	✓	✓	-	-
addPageLine	-	-	-	-	-	-	-	✓*	-	-	-
addPageRectangle	-	-	-	-	-	-	-	✓*	-	-	-
addRotateBegin	-	-	-	-	-	-	-	-	-	-	-
addRotateEnd	-	-	-	-	-	-	-	-	-	-	-
addCut	✓*	✓*	✓*	✓*	✓*	✓*	✓*	✓*	✓*	✓*	✓*
addPulse	✓	✓	✓	✓	✓	✓	✓	✓	✓	✓	✓
addSound	✓*	✓*	✓*	✓*	✓*	✓*	✓*	✓*	✓*	-	-
addFeedPosition	-	-	-	-	-	-	-	-	-	-	✓*
addLayout	-	-	-	-	-	-	-	-	-	-	-
addCommand	✓	✓	✓	✓	✓	✓	✓	✓	✓	✓	✓
getMaintenanceCounter	-	-	-	-	-	-	-	✓	-	-	-
resetMaintenanceCounter	-	-	-	-	-	-	-	✓	-	-	-
getPrinterSetting	-	-	-	-	-	-	-	✓*	-	-	-
setPrinterSetting	-	-	-	-	-	-	-	✓*	-	-	-
downloadFirmwareList	-	-	-	-	-	-	-	✓*	-	-	-
getPrinterFirmwareInfo	-	-	-	-	-	-	-	✓	-	-	-
verifyUpdate	-	-	-	-	-	-	-	✓	-	-	-
updateFirmware	-	-	-	-	-	-	-	✓	-	-	-
forceRecover	-	-	-	-	-	-	-	-	-	-	-
forcePulse	-	-	-	-	-	-	-	-	-	-	-

API	TM-T82II	TM-T82III	TM-T82IIIL	TM-T82X	TM-T83II	TM-T83III	TM-T88V	TM-T88VI	TM-T100	TM-U220	TM-U330
forceStopSound	-	-	-	-	-	-	-	-	-	-	-
forceCommand	-	-	-	-	-	-	-	-	-	-	-
forceReset	-	-	-	-	-	-	-	-	-	-	-
setStatusChangeEventLis- tener	✓	✓	✓	✓	✓	✓	✓	✓	✓	✓	✓
setReceiveEventListener	✓	✓	✓	✓	✓	✓	✓	✓	✓	✓	✓
interval	✓	✓	✓	✓	✓	✓	✓	✓	✓	✓	✓

Mobile models/Hybrid models

API	TM-P20	TM-P60 (Receipt)	TM-P60 (Peeler)	TM-P60II (Receipt)	TM-P60II (Peeler)	TM-P80	TM-H6000V
Printer	✓*	✓*	✓*	✓*	✓*	✓*	✓*
connect	✓	✓	✓	✓	✓	✓	✓
disconnect	✓	✓	✓	✓	✓	✓	✓
startMonitor	✓	✓	✓	✓	✓	✓	✓
stopMonitor	✓	✓	✓	✓	✓	✓	✓
getStatus	✓	✓	✓	✓	✓	✓	✓
sendData	✓	✓	✓	✓	✓	✓	✓
beginTransaction	-	-	-	-	-	-	✓
endTransaction	-	-	-	-	-	-	✓
requestPrintJobStatus	-	-	-	-	-	-	-
clearCommandBuffer	✓	✓	✓	✓	✓	✓	✓
addTextAlign	✓	✓	✓	✓	✓	✓	✓
addLineSpace	✓	✓	✓	✓	✓	✓	✓
addTextRotate	✓	✓	✓	✓	✓	✓	✓
addText	✓	✓	✓	✓	✓	✓	✓
addTextLang	✓*	✓*	✓*	✓*	✓*	✓*	✓*
addTextFont	✓	✓*	✓*	✓*	✓*	✓*	✓*
addTextSmooth	✓	✓	✓	✓	✓	✓	✓
addTextSize	✓	✓	✓	✓	✓	✓	✓
addTextStyle	✓*	✓*	✓*	✓*	✓*	✓*	✓*
addHPosition	✓	✓	✓	✓	✓	✓	✓

API	TM-P20	TM-P60 (Receipt)	TM-P60 (Peeler)	TM-P60II (Receipt)	TM-P60II (Peeler)	TM-P80	TM-H6000V
addFeedUnit	✓	✓	✓	✓	✓	✓	✓
addFeedLine	✓	✓	✓	✓	✓	✓	✓
addImage	✓*	✓*	✓*	✓*	✓*	✓*	✓*
addLogo	✓	✓	✓	✓	✓	✓	✓
addBarcode	✓	✓*	✓*	✓*	✓*	✓*	✓*
addSymbol	✓*	-	✓*	✓*	✓*	✓*	✓*
addHLine	-	-	-	-	-	-	-
addVLineBegin	-	-	-	-	-	-	-
addVLineEnd	-	-	-	-	-	-	-
addPageBegin	✓	✓	✓	✓	✓	✓	✓
addPageEnd	✓	✓	✓	✓	✓	✓	✓
addPageArea	✓	✓	✓	✓	✓	✓	✓
addPageDirection	✓	✓	✓	✓	✓	✓	✓
addPagePosition	✓	✓	✓	✓	✓	✓	✓
addPageLine	✓*	✓*	✓*	✓*	✓*	✓*	✓*
addPageRectangle	✓*	✓*	✓*	✓*	✓*	✓*	✓*
addRotateBegin	-	-	-	-	-	-	-
addRotateEnd	-	-	-	-	-	-	-
addCut	✓*	✓*	✓*	✓*	✓*	✓*	✓*
addPulse	-	-	-	-	-	-	✓
addSound	✓*	-	-	✓*	✓*	✓*	-
addFeedPosition	✓*	-	✓	-	✓	✓*	-
addLayout	✓*	-	✓	-	✓	✓*	-
addCommand	✓	✓	✓	✓	✓	✓	✓
getMaintenanceCounter	✓*	-	-	-	-	-	-
resetMaintenanceCounter	✓*	-	-	-	-	-	-
getPrinterSetting	✓*	-	-	-	-	-	-
setPrinterSetting	✓*	-	-	-	-	-	-
downloadFirmwareList	-	-	-	-	-	-	-
getPrinterFirmwareInfo	-	-	-	-	-	-	-
verifyUpdate	-	-	-	-	-	-	-

API	TM-P20	TM-P60 (Receipt)	TM-P60 (Peeler)	TM-P60II (Receipt)	TM-P60II (Peeler)	TM-P80	TM-H6000V
updateFirmware	-	-	-	-	-	-	-
forceRecover	-	-	-	-	-	-	✓
forcePulse	-	-	-	-	-	-	✓
forceStopSound	-	-	-	-	-	-	-
forceCommand	-	-	-	-	-	-	✓
forceReset	-	-	-	-	-	-	✓
setStatusChangeEventLis- tener	✓	✓	✓	✓	✓	✓	✓
setReceiveEventListener	✓	✓	✓	✓	✓	✓	✓
interval	✓	✓	✓	✓	✓	✓	✓

TM-i Series/TM-DT Series

API	TM-T20II-i	TM-T70-i	TM-T82II-i	TM-T83II-i	TM-T88V-i	TM-T88VI-iHUB	TM-U220-i	TM-T70II-DT	TM-T70II-DT2	TM-T88V-DT	TM-T88VI-DT2	TM-H6000IV-DT
Printer	✓*	✓*	✓*	✓*	✓*	✓*	✓*	✓*	✓*	✓*	✓*	✓*
connect	✓	✓	✓	✓	✓	✓	✓	✓	✓	✓	✓	✓
disconnect	✓	✓	✓	✓	✓	✓	✓	✓	✓	✓	✓	✓
startMonitor	✓	✓	✓	✓	✓	✓	✓	✓	✓	✓	✓	✓
stopMonitor	✓	✓	✓	✓	✓	✓	✓	✓	✓	✓	✓	✓
getStatus	✓	✓	✓	✓	✓	✓	✓	✓	✓	✓	✓	✓
sendData	✓	✓	✓	✓	✓	✓	✓	✓	✓	✓	✓	✓
beginTransaction	-	-	-	-	-	-	-	-	-	-	-	-
endTransaction	-	-	-	-	-	-	-	-	-	-	-	-
requestPrintJobStatus	✓	✓	✓	✓	✓	✓	✓	✓	✓	✓	✓	✓
clearCommandBuffer	✓	✓	✓	✓	✓	✓	✓	✓	✓	✓	✓	✓
addTextAlign	✓	✓	✓	✓	✓	✓	✓	✓	✓	✓	✓	✓
addLineSpace	✓	✓	✓	✓	✓	✓	✓	✓	✓	✓	✓	✓
addTextRotate	✓	✓	✓	✓	✓	✓	✓	✓	✓	✓	✓	✓
addText	✓	✓	✓	✓	✓	✓	✓	✓	✓	✓	✓	✓
addTextLang	✓*	✓*	✓*	✓*	✓*	✓*	✓*	✓*	✓*	✓*	✓*	✓*

API	TM-T20II-i	TM-T70-i	TM-T82II-i	TM-T83II-i	TM-T88V-i	TM-T88VI-iHUB	TM-U220-i	TM-T70II-DT	TM-T70II-DT2	TM-T88V-DT	TM-T88VI-DT2	TM-H6000IV-DT
addTextFont	✓*	✓*	✓*	✓*	✓*	✓*	✓*	✓*	✓*	✓*	✓*	✓*
addTextSmooth	✓	✓	✓	✓	✓	✓	✓	✓	✓	✓	✓	✓
addTextSize	✓	✓	✓	✓	✓	✓	-	✓	✓	✓	✓	✓
addTextStyle	✓*	✓*	✓*	✓*	✓*	✓*	✓*	✓*	✓*	✓*	✓*	✓*
addHPosition	✓	✓	✓	✓	✓	✓	-	✓	✓	✓	✓	✓
addFeedUnit	✓	✓	✓	✓	✓	✓	✓	✓	✓	✓	✓	✓
addFeedLine	✓	✓	✓	✓	✓	✓	✓	✓	✓	✓	✓	✓
addImage	✓*	✓*	✓*	✓*	✓*	✓*	✓*	✓*	✓*	✓*	✓*	✓*
addLogo	✓	✓	✓	✓	✓	✓	-	✓	✓	✓	✓	✓
addBarcode	✓*	✓*	✓*	✓*	✓*	✓*	-	✓*	✓*	✓*	✓*	✓*
addSymbol	✓*	✓*	✓*	✓*	✓*	✓*	-	✓*	✓*	✓*	✓*	✓*
addHLine	-	-	-	-	-	-	-	-	-	-	-	-
addVLineBegin	-	-	-	-	-	-	-	-	-	-	-	-
addVLineEnd	-	-	-	-	-	-	-	-	-	-	-	-
addPageBegin	✓	✓	✓	✓	✓	✓	-	✓	✓	✓	✓	✓
addPageEnd	✓	✓	✓	✓	✓	✓	-	✓	✓	✓	✓	✓
addPageArea	✓	✓	✓	✓	✓	✓	-	✓	✓	✓	✓	✓
addPageDirection	✓	✓	✓	✓	✓	✓	-	✓	✓	✓	✓	✓
addPagePosition	✓	✓	✓	✓	✓	✓	-	✓	✓	✓	✓	✓
addPageLine	-	-	-	-	-	✓*	-	-	-	-	-	-
addPageRectangle	-	-	-	-	-	✓*	-	-	-	-	-	-
addRotateBegin	-	-	-	-	-	-	-	-	-	-	-	-
addRotateEnd	-	-	-	-	-	-	-	-	-	-	-	-
addCut	✓*	✓*	✓*	✓*	✓*	✓*	✓*	✓*	✓*	✓*	✓*	✓*
addPulse	✓	✓	✓	✓	✓	✓	✓	✓	✓	✓	✓	✓
addSound	✓*	-	✓*	✓*	✓*	✓*	-	✓*	✓*	✓*	✓*	-
addFeedPosition	-	-	-	-	-	-	-	-	-	-	-	-
addLayout	-	-	-	-	-	-	-	-	-	-	-	-
addCommand	✓	✓	✓	✓	✓	✓	✓	✓	✓	✓	✓	✓
getMaintenanceCounter	-	-	-	-	-	✓	-	-	-	-	-	-
resetMaintenanceCounter	-	-	-	-	-	✓	-	-	-	-	-	-
getPrinterSetting	-	-	-	-	-	✓*	-	-	-	-	-	-

API	TM-T20II-i	TM-T70-i	TM-T82II-i	TM-T83II-i	TM-T88V-i	TM-T88VI-iHUB	TM-U220-i	TM-T70II-DT	TM-T70II-DT2	TM-T88V-DT	TM-T88VI-DT2	TM-H6000IV-DT
setPrinterSetting	-	-	-	-	-	✓*	-	-	-	-	-	-
downloadFirmwareList	-	-	-	-	-	✓*	-	-	-	-	-	-
getPrinterFirmwareInfo	-	-	-	-	-	✓	-	-	-	-	-	-
verifyUpdate	-	-	-	-	-	✓	-	-	-	-	-	-
updateFirmware	-	-	-	-	-	✓	-	-	-	-	-	-
forceRecover	✓	✓	✓	✓	✓	✓	-	✓	✓	✓	✓	✓
forcePulse	✓	✓	✓	✓	✓	✓	✓	✓	✓	✓	✓	✓
forceStopSound	✓	-	✓	✓	✓	✓	-	✓	✓	✓	✓	-
forceCommand	✓	✓	✓	✓	✓	✓	✓	✓	✓	✓	✓	✓
forceReset	✓	✓	✓	✓	✓	✓	✓	✓	✓	✓	✓	✓
setStatusChangeEventLis- tener	✓	✓	✓	✓	✓	✓	✓	✓	✓	✓	✓	✓
setReceiveEventListener	✓	✓	✓	✓	✓	✓	✓	✓	✓	✓	✓	✓
interval	✓	✓	✓	✓	✓	✓	✓	✓	✓	✓	✓	✓

Slave Printers

API	TM-T88IV	TM-T90	TM-L90	TM-H6000IV
Printer	✓*	✓*	✓*	✓*
connect	✓	✓	✓	✓
disconnect	✓	✓	✓	✓
startMonitor	✓	✓	✓	✓
stopMonitor	✓	✓	✓	✓
getStatus	✓	✓	✓	✓
sendData	✓	✓	✓	✓
beginTransaction	-	-	-	-
endTransaction	-	-	-	-
requestPrintJobStatus	-	-	-	-
clearCommandBuffer	✓	✓	✓	✓
addTextAlign	✓	✓	✓	✓
addLineSpace	✓	✓	✓	✓
addTextRotate	✓	✓	✓	✓

API	TM-T88IV	TM-T90	TM-L90	TM-H6000IV
addText	✓	✓	✓	✓
addTextLang	✓*	✓*	✓*	✓*
addTextFont	✓*	✓*	✓*	✓*
addTextSmooth	✓	✓	✓	✓
addTextSize	✓	✓	✓	✓
addTextStyle	✓*	✓*	✓*	✓*
addHPosition	✓	✓	✓	✓
addFeedUnit	✓	✓	✓	✓
addFeedLine	✓	✓	✓	✓
addImage	✓*	✓*	✓*	✓*
addLogo	✓	✓	✓	✓
addBarcode	✓*	✓*	✓*	✓*
addSymbol	✓*	✓*	✓*	✓*
addHLine	-	-	-	-
addVLineBegin	-	-	-	-
addVLineEnd	-	-	-	-
addPageBegin	✓	✓	✓	✓
addPageEnd	✓	✓	✓	✓
addPageArea	✓	✓	✓	✓
addPageDirection	✓	✓	✓	✓
addPagePosition	✓	✓	✓	✓
addPageLine	-	-	-	-
addPageRectangle	-	-	-	-
addRotateBegin	-	-	-	-
addRotateEnd	-	-	-	-
addCut	✓*	✓*	✓*	✓*
addPulse	✓	✓	✓	✓
addSound	-	-	-	-
addFeedPosition	-	-	✓	-
addLayout	-	-	-	-
addCommand	✓	✓	✓	✓
getMaintenanceCounter	-	-	-	-
resetMaintenanceCounter	-	-	-	-

API	TM-T88IV	TM-T90	TM-L90	TM-H6000IV
getPrinterSetting	-	-	-	-
setPrinterSetting	-	-	-	-
downloadFirmwareList	-	-	-	-
getPrinterFirmwareInfo	-	-	-	-
verifyUpdate	-	-	-	-
updateFirmware	-	-	-	-
forceRecover	-	-	-	-
forcePulse	-	-	-	-
forceStopSound	-	-	-	-
forceCommand	-	-	-	-
forceReset	-	-	-	-
setStatusChangeListener	✓	✓	✓	✓
setReceiveEventListener	✓	✓	✓	✓
interval	✓	✓	✓	✓

LineDisplay class

Single-function models (1)

API	TM-m10	TM-m30	TM-m30II	TM-m30II-H	TM-T20	TM-T20II	TM-T20III	TM-T20IIIL	TM-T20X	TM-T60	TM-T70	TM-T70II	TM-T81II	TM-T81III	TM-T82
LineDisplay	-	✓*	✓*	✓*	-	-	-	-	-	-	-	-	-	-	-
connect	-	✓	✓	✓	-	-	-	-	-	-	-	-	-	-	-
disconnect	-	✓	✓	✓	-	-	-	-	-	-	-	-	-	-	-
getStatus	-	✓	✓	✓	-	-	-	-	-	-	-	-	-	-	-
sendData	-	✓	✓	✓	-	-	-	-	-	-	-	-	-	-	-
clearCommandBuffer	-	✓	✓	✓	-	-	-	-	-	-	-	-	-	-	-
addInitialize	-	✓	✓	✓	-	-	-	-	-	-	-	-	-	-	-
addCreateWindow	-	✓	✓	✓	-	-	-	-	-	-	-	-	-	-	-
addDestroyWindow	-	✓	✓	✓	-	-	-	-	-	-	-	-	-	-	-
addSetCurrentWindow	-	✓	✓	✓	-	-	-	-	-	-	-	-	-	-	-
addClearCurrentWindow	-	✓	✓	✓	-	-	-	-	-	-	-	-	-	-	-
addSetCursorPosition	-	✓	✓	✓	-	-	-	-	-	-	-	-	-	-	-
addMoveCursorPosition	-	✓	✓	✓	-	-	-	-	-	-	-	-	-	-	-
addSetCursorType	-	✓	✓	✓	-	-	-	-	-	-	-	-	-	-	-
addText	-	✓	✓	✓	-	-	-	-	-	-	-	-	-	-	-
addReverseText	-	✓	✓	✓	-	-	-	-	-	-	-	-	-	-	-
addMarqueeText	-	✓	✓	✓	-	-	-	-	-	-	-	-	-	-	-
addSetBlink	-	✓	✓	✓	-	-	-	-	-	-	-	-	-	-	-
addSetBrightness	-	✓	✓	✓	-	-	-	-	-	-	-	-	-	-	-
addShowClock	-	-	-	-	-	-	-	-	-	-	-	-	-	-	-
addCommand	-	✓	✓	✓	-	-	-	-	-	-	-	-	-	-	-
setReceiveEventListener	-	✓	✓	✓	-	-	-	-	-	-	-	-	-	-	-

Single-function models (2)

API	TM-T82II	TM-T82III	TM-T82IIIL	TM-T82X	TM-T83II	TM-T83III	TM-T88V	TM-T88VI	TM-T100	TM-U220	TM-U330
LineDisplay	-	-	-	-	-	-	-	✓*	-	-	-
connect	-	-	-	-	-	-	-	✓	-	-	-
disconnect	-	-	-	-	-	-	-	✓	-	-	-

API	TM-T82II	TM-T82III	TM-T82IIIL	TM-T82X	TM-T83II	TM-T83III	TM-T88V	TM-T88VI	TM-T100	TM-U220	TM-U330
getStatus	-	-	-	-	-	-	-	✓	-	-	-
sendData	-	-	-	-	-	-	-	✓	-	-	-
clearCommandBuffer	-	-	-	-	-	-	-	✓	-	-	-
addInitialize	-	-	-	-	-	-	-	✓	-	-	-
addCreateWindow	-	-	-	-	-	-	-	✓	-	-	-
addDestroyWindow	-	-	-	-	-	-	-	✓	-	-	-
addSetCurrentWindow	-	-	-	-	-	-	-	✓	-	-	-
addClearCurrentWindow	-	-	-	-	-	-	-	✓	-	-	-
addSetCursorPosition	-	-	-	-	-	-	-	✓	-	-	-
addMoveCursorPosition	-	-	-	-	-	-	-	✓	-	-	-
addSetCursorType	-	-	-	-	-	-	-	✓	-	-	-
addText	-	-	-	-	-	-	-	✓	-	-	-
addReverseText	-	-	-	-	-	-	-	✓	-	-	-
addMarqueeText	-	-	-	-	-	-	-	✓	-	-	-
addSetBlink	-	-	-	-	-	-	-	✓	-	-	-
addSetBrightness	-	-	-	-	-	-	-	✓	-	-	-
addShowClock	-	-	-	-	-	-	-	✓	-	-	-
addCommand	-	-	-	-	-	-	-	✓	-	-	-
setReceiveEventListener	-	-	-	-	-	-	-	✓	-	-	-

Mobile models/Hybrid models

API	TM-P20	TM-P60 (Receipt)	TM-P60 (Peeler)	TM-P60II (Receipt)	TM-P60II (Peeler)	TM-P80	TM-H6000V
LineDisplay	-	-	-	-	-	-	✓*
connect	-	-	-	-	-	-	✓
disconnect	-	-	-	-	-	-	✓
getStatus	-	-	-	-	-	-	✓
sendData	-	-	-	-	-	-	✓
clearCommandBuffer	-	-	-	-	-	-	✓
addInitialize	-	-	-	-	-	-	✓
addCreateWindow	-	-	-	-	-	-	✓

API	TM-P20	TM-P60 (Receipt)	TM-P60 (Peeler)	TM-P60II (Receipt)	TM-P60II (Peeler)	TM-P80	TM-H6000V
addDestroyWindow	-	-	-	-	-	-	✓
addSetCurrentWindow	-	-	-	-	-	-	✓
addClearCurrentWindow	-	-	-	-	-	-	✓
addSetCursorPosition	-	-	-	-	-	-	✓
addMoveCursorPosition	-	-	-	-	-	-	✓
addSetCursorType	-	-	-	-	-	-	✓
addText	-	-	-	-	-	-	✓
addReverseText	-	-	-	-	-	-	✓
addMarqueeText	-	-	-	-	-	-	✓
addSetBlink	-	-	-	-	-	-	✓
addSetBrightness	-	-	-	-	-	-	✓
addShowClock	-	-	-	-	-	-	✓
addCommand	-	-	-	-	-	-	✓
setReceiveEventListener	-	-	-	-	-	-	✓

TM-i Series/TM-DT Series

API	TM-T20II-i	TM-T70-i	TM-T82II-i	TM-T83II-i	TM-T88V-i	TM-T88VI-iHUB	TM-UJ220-i	TM-T70II-DT	TM-T70II-DT2	TM-T88V-DT	TM-T88VI-DT2	TM-H6000IV-DT
LineDisplay	✓*	✓*	✓*	✓*	✓*	✓*	✓*	✓*	✓*	✓*	✓*	✓*
connect	✓	✓	✓	✓	✓	✓	✓	✓	✓	✓	✓	✓
disconnect	✓	✓	✓	✓	✓	✓	✓	✓	✓	✓	✓	✓
getStatus	✓	✓	✓	✓	✓	✓	✓	✓	✓	✓	✓	✓
sendData	✓	✓	✓	✓	✓	✓	✓	✓	✓	✓	✓	✓
clearCommandBuffer	✓	✓	✓	✓	✓	✓	✓	✓	✓	✓	✓	✓
addInitialize	✓	✓	✓	✓	✓	✓	✓	✓	✓	✓	✓	✓
addCreateWindow	✓	✓	✓	✓	✓	✓	✓	✓	✓	✓	✓	✓
addDestroyWindow	✓	✓	✓	✓	✓	✓	✓	✓	✓	✓	✓	✓
addSetCurrentWindow	✓	✓	✓	✓	✓	✓	✓	✓	✓	✓	✓	✓
addClearCurrentWindow	✓	✓	✓	✓	✓	✓	✓	✓	✓	✓	✓	✓
addSetCursorPosition	✓	✓	✓	✓	✓	✓	✓	✓	✓	✓	✓	✓

API	TM-T20II-i	TM-T70-i	TM-T82II-i	TM-T83II-i	TM-T88V-i	TM-T88VI-iHUB	TM-U220-i	TM-T70II-DT	TM-T70II-DT2	TM-T88V-DT	TM-T88VI-DT2	TM-H6000IV-DT
addMoveCursorPosition	✓	✓	✓	✓	✓	✓	✓	✓	✓	✓	✓	✓
addSetCursorPosition	✓	✓	✓	✓	✓	✓	✓	✓	✓	✓	✓	✓
addText	✓	✓	✓	✓	✓	✓	✓	✓	✓	✓	✓	✓
addReverseText	✓	✓	✓	✓	✓	✓	✓	✓	✓	✓	✓	✓
addMarqueeText	✓	✓	✓	✓	✓	✓	✓	✓	✓	✓	✓	✓
addSetBlink	✓	✓	✓	✓	✓	✓	✓	✓	✓	✓	✓	✓
addSetBrightness	✓	✓	✓	✓	✓	✓	✓	✓	✓	✓	✓	✓
addShowClock	✓	✓	✓	✓	✓	✓	✓	✓	✓	✓	✓	✓
addCommand	✓	✓	✓	✓	✓	✓	✓	✓	✓	✓	✓	✓
setReceiveEventListener	✓	✓	✓	✓	✓	✓	✓	✓	✓	✓	✓	✓

Slave Printers

API	TM-T88IV	TM-T90	TM-L90	TM-H6000IV
LineDisplay	-	-	-	-
connect	-	-	-	-
disconnect	-	-	-	-
getStatus	-	-	-	-
sendData	-	-	-	-
clearCommandBuffer	-	-	-	-
addInitialize	-	-	-	-
addCreateWindow	-	-	-	-
addDestroyWindow	-	-	-	-
addSetCurrentWindow	-	-	-	-
addClearCurrentWindow	-	-	-	-
addSetCursorPosition	-	-	-	-
addMoveCursorPosition	-	-	-	-
addSetCursorPosition	-	-	-	-
addText	-	-	-	-
addReverseText	-	-	-	-
addMarqueeText	-	-	-	-

API	TM-T88IV	TM-T90	TM-L90	TM-H6000IV
addSetBlink	-	-	-	-
addSetBrightness	-	-	-	-
addShowClock	-	-	-	-
addCommand	-	-	-	-
setReceiveEventListener	-	-	-	-

Common to all classes

Single-function models (1)

API	TM-m10	TM-m30	TM-m30II	TM-m30II-H	TM-T20	TM-T20II	TM-T20III	TM-T20IIIL	TM-T20X	TM-T60	TM-T70	TM-T70II	TM-T81II	TM-T81III	TM-T82
getAdmin	✓	✓	✓	✓	✓	✓	✓	✓	✓	✓	✓	✓	✓	✓	✓
getLocation	✓	✓	✓	✓	✓	✓	✓	✓	✓	✓	✓	✓	✓	✓	✓
setConnectionEventListener	-	-	-	-	-	-	-	-	-	-	-	-	-	-	-

Single-function models (2)

API	TM-T82II	TM-T82III	TM-T82IIIL	TM-T82X	TM-T83II	TM-T83III	TM-T88V	TM-T88VI	TM-T100	TM-U220	TM-U330
getAdmin	✓	✓	✓	✓	✓	✓	✓	✓	✓	✓	✓
getLocation	✓	✓	✓	✓	✓	✓	✓	✓	✓	✓	✓
setConnectionEventListener	-	-	-	-	-	-	-	-	-	-	-

Mobile models/Hybrid models

API	TM-P20	TM-P60 (Receipt)	TM-P60 (Peeler)	TM-P60II (Receipt)	TM-P60II (Peeler)	TM-P80	TM-H6000V
getAdmin	✓	✓	✓	✓	✓	✓	✓
getLocation	✓	✓	✓	✓	✓	✓	✓
setConnectionEventListener	-	-	-	-	-	-	✓

TM-i Series/TM-DT Series

API	TM-T20II-i	TM-T70-i	TM-T82II-i	TM-T83II-i	TM-T88V-i	TM-T88VI-iHUB	TM-U220-i	TM-T70II-DT	TM-T70II-DT2	TM-T88V-DT	TM-T88VI-DT2	TM-H6000IV-DT
getAdmin	✓	✓	✓	✓	✓	✓	✓	✓	✓	✓	✓	✓
getLocation	✓	✓	✓	✓	✓	✓	✓	✓	✓	✓	✓	✓

API	TM-T20II-i	TM-T70-i	TM-T82II-i	TM-T83II-i	TM-T88V-i	TM-T88VI-iHUB	TM-U220-i	TM-T70II-DT	TM-T70II-DT2	TM-T88V-DT	TM-T88VI-DT2	TM-H6000IV-DT
setConnectionEventListener	✓	✓	✓	✓	✓	✓	✓	✓	✓	✓	✓	✓

Slave Printers

API	TM-T88IV	TM-T90	TM-L90	TM-H6000IV
getAdmin	-	-	-	-
getLocation	-	-	-	-
setConnectionEventListener	-	-	-	-

EasySelect class

Single-function models (1)

API	TM-m10	TM-m30	TM-m30II	TM-m30II-H	TM-T20	TM-T20II	TM-T20III	TM-T20IIIL	TM-T20X	TM-T60	TM-T70	TM-T70II	TM-T81II	TM-T81III	TM-T82
parseNFC	✓	✓	✓	✓	-	-	-	-	-	-	-	-	-	-	-
parseQR	✓	✓	✓	✓	✓	✓	✓	✓	✓	✓	✓	✓	✓	✓	✓
createQR	✓	✓	✓	✓	✓	✓	✓	✓	✓	✓	✓	✓	✓	✓	✓

Single-function models (2)

API	TM-T82II	TM-T82III	TM-T82IIIL	TM-T82X	TM-T83II	TM-T83III	TM-T88V	TM-T88VI	TM-T100	TM-U220	TM-U330
parseNFC	-	-	-	-	-	-	-	✓	-	-	-
parseQR	✓	✓	✓	✓	✓	✓	✓	✓	✓	✓	✓
createQR	✓	✓	✓	✓	✓	✓	✓	✓	✓	✓	✓

Mobile models/Hybrid models

API	TM-P20	TM-P60 (Receipt)	TM-P60 (Peeler)	TM-P60II (Receipt)	TM-P60II (Peeler)	TM-P80	TM-H6000V
parseNFC	✓	✓	✓	✓	✓	✓	✓
parseQR	✓	✓	✓	✓	✓	✓	✓
createQR	✓	✓	✓	✓	✓	✓	✓

TM-i Series/TM-DT Series

API	TM-T20II-i	TM-T70-i	TM-T82II-i	TM-T83II-i	TM-T88V-i	TM-T88VI-iHUB	TM-U220-i	TM-T70II-DT	TM-T70II-DT2	TM-T88V-DT	TM-T88VI-DT2	TM-H6000IV-DT
parseNFC	-	-	-	-	-	✓	-	-	-	-	-	-
parseQR	-	-	-	-	-	-	-	-	-	-	-	-
createQR	-	-	-	-	-	-	-	-	-	-	-	-

Slave Printers

API	TM-T88IV	TM-T90	TM-L90	TM-H6000IV
parseNFC	-	-	-	-
parseQR	-	-	-	-
createQR	-	-	-	-

Printer-specific Support Information

TM-m10

Printer Specifications

Item	Specification
Amount of initial feed	30 dots
Initial page mode area	420 x 2400 dots
Maximum page mode area	420 x 2400 dots
Baseline of Font A	21 dots from the top of the character
Baseline of Font B	21 dots from the top of the character
Baseline of Font C	16 dots from the top of the character

Parameter Restrictions

API	Parameter	Specificable Setting Value
Printer	printerSeries	<ul style="list-style-type: none"> Printer.TM_M10
	lang	<ul style="list-style-type: none"> Printer.MODEL_ANK Printer.MODEL_TAIWAN
addTextLang	lang	<ul style="list-style-type: none"> Printer.LANG_EN (default) Printer.LANG_JA Printer.LANG_ZH_CN Printer.LANG_ZH_TW Printer.LANG_KO Printer.LANG_TH Printer.LANG_VI Printer.PARAM_DEFAULT
addTextFont	font	<ul style="list-style-type: none"> Printer.FONT_A (default) Printer.FONT_B Printer.FONT_C Printer.PARAM_DEFAULT
addTextStyle	color	<ul style="list-style-type: none"> Printer.COLOR_1 (default) Printer.PARAM_UNSPECIFIED Printer.PARAM_DEFAULT
addImage	color	<ul style="list-style-type: none"> Printer.COLOR_1 Printer.PARAM_DEFAULT
	mode	<ul style="list-style-type: none"> Printer.MODE_MONO Printer.MODE_MONO_HIGH_DENSITY Printer.PARAM_DEFAULT

API	Parameter	Specifiable Setting Value
addBarcode	font	<ul style="list-style-type: none"> • Printer.FONT_A (default) • Printer.FONT_B • Printer.FONT_C • Printer.PARAM_DEFAULT • Printer.PARAM_UNSPECIFIED
addSymbol	type	<ul style="list-style-type: none"> • Printer.SYMBOL_PDF417_STANDARD • Printer.SYMBOL_PDF417_TRUNCATED • Printer.SYMBOL_QRCODE_MODEL_1 • Printer.SYMBOL_QRCODE_MODEL_2 • Printer.SYMBOL_MAXICODE_MODE_2 • Printer.SYMBOL_MAXICODE_MODE_3 • Printer.SYMBOL_MAXICODE_MODE_4 • Printer.SYMBOL_MAXICODE_MODE_5 • Printer.SYMBOL_MAXICODE_MODE_6 • Printer.SYMBOL_GS1_DATABAR_STACKED • Printer.SYMBOL_GS1_DATABAR_STACKED_OMNIDIRECTIONAL • Printer.SYMBOL_GS1_DATABAR_EXPANDED_STACKED • Printer.SYMBOL_AZTECCODE_FULLRANGE • Printer.SYMBOL_AZTECCODE_COMPACT • Printer.SYMBOL_DATAMATRIX_SQUARE • Printer.SYMBOL_DATAMATRIX_RECTANGLE_8 • Printer.SYMBOL_DATAMATRIX_RECTANGLE_12 • Printer.SYMBOL_DATAMATRIX_RECTANGLE_16
addPageLine	lineStyle	<ul style="list-style-type: none"> • Printer.LINE_THIN • Printer.LINE_MEDIUM • Printer.LINE_THICK • Printer.PARAM_DEFAULT
addPageRectangle	lineStyle	<ul style="list-style-type: none"> • Printer.LINE_THIN • Printer.LINE_MEDIUM • Printer.LINE_THICK • Printer.PARAM_DEFAULT
addCut	type	<ul style="list-style-type: none"> • Printer.CUT_FEED • Printer.CUT_NO_FEED • Printer.PARAM_DEFAULT

API	Parameter	Specificable Setting Value
addSound	pattern	<ul style="list-style-type: none"> • Printer.PATTERN_NONE • Printer.PATTERN_A • Printer.PATTERN_B • Printer.PATTERN_C • Printer.PATTERN_D • Printer.PATTERN_E • Printer.PATTERN_ERROR • Printer.PATTERN_PAPER_EMPTY • Printer.PARAM_DEFAULT
	repeat	<ul style="list-style-type: none"> • 1 to 255 • Printer.PARAM_DEFAULT
downloadFirmwareList	printerModel	<ul style="list-style-type: none"> • TM-m10

TM-m30

Printer Specifications

Item		58mm Specification	80mm Specification
Amount of initial feed		30 dots	
Initial page mode area		420 x 2400 dots	576 x 2400 dots
Maximum page mode area		420 x 2400 dots	576 x 2400 dots
Baseline of Font A		21 dots from the top of the character	
Baseline of Font B	ANK	21 dots from the top of the character	
	Chinese characters	21 dots from the top of the character	
	Hangul character	15 dots from the top of the character	
Baseline of Font C		16 dots from the top of the character	

Parameter Restrictions

API	Parameter	Specificable Setting Value
Printer	printerSeries	<ul style="list-style-type: none"> Printer.TM_M30
	lang	<ul style="list-style-type: none"> Printer.MODEL_ANK Printer.MODEL_CHINESE Printer.MODEL_TAIWAN Printer.MODEL_KOREAN Printer.MODEL_SOUTHASIA
addTextLang	lang	<ul style="list-style-type: none"> Printer.LANG_EN (default) Printer.LANG_JA Printer.LANG_ZH_CN Printer.LANG_ZH_TW Printer.LANG_KO Printer.LANG_TH Printer.LANG_VI Printer.PARAM_DEFAULT
addTextFont	font	<ul style="list-style-type: none"> Printer.FONT_A (default) Printer.FONT_B Printer.FONT_C Printer.PARAM_DEFAULT
addTextStyle	color	<ul style="list-style-type: none"> Printer.COLOR_1 (default) Printer.PARAM_UNSPECIFIED Printer.PARAM_DEFAULT

API	Parameter	Specifiable Setting Value
addImage	color	<ul style="list-style-type: none"> • Printer.COLOR_1 • Printer.PARAM_DEFAULT
	mode	<ul style="list-style-type: none"> • Printer.MODE_MONO • Printer.MODE_MONO_HIGH_DENSITY • Printer.PARAM_DEFAULT
addBarcode	font	<ul style="list-style-type: none"> • Printer.FONT_A (default) • Printer.FONT_B • Printer.FONT_C • Printer.PARAM_DEFAULT • Printer.PARAM_UNSPECIFIED
addSymbol	type	<ul style="list-style-type: none"> • Printer.SYMBOL_PDF417_STANDARD • Printer.SYMBOL_PDF417_TRUNCATED • Printer.SYMBOL_QRCODE_MODEL_1 • Printer.SYMBOL_QRCODE_MODEL_2 • Printer.SYMBOL_MAXICODE_MODE_2 • Printer.SYMBOL_MAXICODE_MODE_3 • Printer.SYMBOL_MAXICODE_MODE_4 • Printer.SYMBOL_MAXICODE_MODE_5 • Printer.SYMBOL_MAXICODE_MODE_6 • Printer.SYMBOL_GS1_DATABAR_STACKED • Printer.SYMBOL_GS1_DATABAR_STACKED_OMNIDIRECTIONAL • Printer.SYMBOL_GS1_DATABAR_EXPANDED_STACKED • Printer.SYMBOL_AZTECCODE_FULLRANGE • Printer.SYMBOL_AZTECCODE_COMPACT • Printer.SYMBOL_DATAMATRIX_SQUARE • Printer.SYMBOL_DATAMATRIX_RECTANGLE_8 • Printer.SYMBOL_DATAMATRIX_RECTANGLE_12 • Printer.SYMBOL_DATAMATRIX_RECTANGLE_16
addPageLine	lineStyle	<ul style="list-style-type: none"> • Printer.LINE_THIN • Printer.LINE_MEDIUM • Printer.LINE_THICK • Printer.PARAM_DEFAULT
addPageRectangle	lineStyle	<ul style="list-style-type: none"> • Printer.LINE_THIN • Printer.LINE_MEDIUM • Printer.LINE_THICK • Printer.PARAM_DEFAULT
addCut	type	<ul style="list-style-type: none"> • Printer.CUT_FEED • Printer.CUT_NO_FEED • Printer.PARAM_DEFAULT

API	Parameter	Specificable Setting Value
addSound	pattern	<ul style="list-style-type: none"> • Printer.PATTERN_NONE • Printer.PATTERN_A • Printer.PATTERN_B • Printer.PATTERN_C • Printer.PATTERN_D • Printer.PATTERN_E • Printer.PATTERN_ERROR • Printer.PATTERN_PAPER_EMPTY • Printer.PARAM_DEFAULT
	repeat	<ul style="list-style-type: none"> • 1 to 255 • Printer.PARAM_DEFAULT
setPrinterSetting	value	<ul style="list-style-type: none"> • Printer.Setting.PaperWidth58_0 • Printer.Setting.PaperWidth80_0 • Printer.Setting.PrintDensity70 • Printer.Setting.PrintDensity75 • Printer.Setting.PrintDensity80 • Printer.Setting.PrintDensity85 • Printer.Setting.PrintDensity90 • Printer.Setting.PrintDensity95 • Printer.Setting.PrintDensity100 • Printer.Setting.PrintDensity105 • Printer.Setting.PrintDensity110 • Printer.Setting.PrintDensity115 • Printer.Setting.PrintDensity120 • Printer.Setting.PrintDensity125 • Printer.Setting.PrintDensity130 • Printer.Setting.PrintSpeed1 • Printer.Setting.PrintSpeed2 • Printer.Setting.PrintSpeed3 • Printer.Setting.PrintSpeed4 • Printer.Setting.PrintSpeed5 • Printer.Setting.PrintSpeed6 • Printer.Setting.PrintSpeed7 • Printer.Setting.PrintSpeed8 • Printer.Setting.PrintSpeed9 • Printer.Setting.PrintSpeed10
downloadFirmwareList	printerModel	<ul style="list-style-type: none"> • TM-m30
LineDisplay	displaySeries	<ul style="list-style-type: none"> • LineDisplay.DM_D30

TM-m30II**Printer Specifications**

Item	58mm Specification	80mm Specification
Amount of initial feed	30 dots	
Initial page mode area	420 x 4800 dots	576 x 4800 dots
Maximum page mode area	420 x 4800 dots	576 x 4800 dots
Baseline of Font A	21 dots from the top of the character	
Baseline of Font B	21 dots from the top of the character	
Baseline of Font C	16 dots from the top of the character	

Parameter Restrictions

API	Parameter	Specificable Setting Value
Printer	printerSeries	<ul style="list-style-type: none"> • Printer.TM_M30II
addTextLang	lang	<ul style="list-style-type: none"> • Printer.LANG_EN (default) • Printer.LANG_JA • Printer.LANG_ZH_CN • Printer.LANG_ZH_TW • Printer.LANG_KO • Printer.LANG_TH • Printer.LANG_VI • Printer.PARAM_DEFAULT
addTextFont	font	<ul style="list-style-type: none"> • Printer.FONT_A (default) • Printer.FONT_B • Printer.FONT_C • Printer.PARAM_DEFAULT
addTextStyle	color	<ul style="list-style-type: none"> • Printer.COLOR_1 (default) • Printer.PARAM_UNSPECIFIED • Printer.PARAM_DEFAULT
addImage	color	<ul style="list-style-type: none"> • Printer.COLOR_1 • Printer.PARAM_DEFAULT
	mode	<ul style="list-style-type: none"> • Printer.MODE_MONO • Printer.MODE_MONO_HIGH_DENSITY • Printer.PARAM_DEFAULT
addBarcode	font	<ul style="list-style-type: none"> • Printer.FONT_A (default) • Printer.FONT_B • Printer.FONT_C • Printer.PARAM_DEFAULT • Printer.PARAM_UNSPECIFIED

API	Parameter	Specificable Setting Value
addSymbol	type	<ul style="list-style-type: none"> • Printer.SYMBOL_PDF417_STANDARD • Printer.SYMBOL_PDF417_TRUNCATED • Printer.SYMBOL_QRCODE_MODEL_1 • Printer.SYMBOL_QRCODE_MODEL_2 • Printer.SYMBOL_MAXICODE_MODE_2 • Printer.SYMBOL_MAXICODE_MODE_3 • Printer.SYMBOL_MAXICODE_MODE_4 • Printer.SYMBOL_MAXICODE_MODE_5 • Printer.SYMBOL_MAXICODE_MODE_6 • Printer.SYMBOL_GS1_DATABAR_STACKED • Printer.SYMBOL_GS1_DATABAR_STACKED_OMNIDIRECTIONAL • Printer.SYMBOL_GS1_DATABAR_EXPANDED_STACKED • Printer.SYMBOL_AZTECCODE_FULLRANGE • Printer.SYMBOL_AZTECCODE_COMPACT • Printer.SYMBOL_DATAMATRIX_SQUARE • Printer.SYMBOL_DATAMATRIX_RECTANGLE_8 • Printer.SYMBOL_DATAMATRIX_RECTANGLE_12 • Printer.SYMBOL_DATAMATRIX_RECTANGLE_16
addPageLine	lineStyle	<ul style="list-style-type: none"> • Printer.LINE_THIN • Printer.LINE_MEDIUM • Printer.LINE_THICK • Printer.PARAM_DEFAULT
addPageRectangle	lineStyle	<ul style="list-style-type: none"> • Printer.LINE_THIN • Printer.LINE_MEDIUM • Printer.LINE_THICK • Printer.PARAM_DEFAULT
addCut	type	<ul style="list-style-type: none"> • Printer.CUT_FEED • Printer.CUT_NO_FEED • Printer.PARAM_DEFAULT
addSound	pattern	<ul style="list-style-type: none"> • Printer.PATTERN_NONE • Printer.PATTERN_A • Printer.PATTERN_B • Printer.PATTERN_C • Printer.PATTERN_D • Printer.PATTERN_E • Printer.PATTERN_ERROR • Printer.PATTERN_PAPER_EMPTY • Printer.PARAM_DEFAULT
	repeat	<ul style="list-style-type: none"> • 1 to 255 • Printer.PARAM_DEFAULT

API	Parameter	Specifiable Setting Value
setPrinterSetting	value	<ul style="list-style-type: none"> • Printer.Setting.PaperWidth58_0 • Printer.Setting.PaperWidth80_0 • Printer.Setting.PrintDensity70 • Printer.Setting.PrintDensity75 • Printer.Setting.PrintDensity80 • Printer.Setting.PrintDensity85 • Printer.Setting.PrintDensity90 • Printer.Setting.PrintDensity95 • Printer.Setting.PrintDensity100 • Printer.Setting.PrintDensity105 • Printer.Setting.PrintDensity110 • Printer.Setting.PrintDensity115 • Printer.Setting.PrintDensity120 • Printer.Setting.PrintDensity125 • Printer.Setting.PrintDensity130 • Printer.Setting.PrintSpeed1 • Printer.Setting.PrintSpeed2 • Printer.Setting.PrintSpeed3 • Printer.Setting.PrintSpeed4 • Printer.Setting.PrintSpeed5 • Printer.Setting.PrintSpeed6 • Printer.Setting.PrintSpeed7 • Printer.Setting.PrintSpeed8 • Printer.Setting.PrintSpeed9 • Printer.Setting.PrintSpeed10 • Printer.Setting.PrintSpeed11 • Printer.Setting.PrintSpeed12 • Printer.Setting.PrintSpeed13
LineDisplay	displaySeries	<ul style="list-style-type: none"> • LineDisplay.DM_D30

TM-m30II-H**Printer Specifications**

Item	58mm Specification	80mm Specification
Amount of initial feed	30 dots	
Initial page mode area	420 x 4800 dots	576 x 4800 dots
Maximum page mode area	420 x 4800 dots	576 x 4800 dots
Baseline of Font A	21 dots from the top of the character	
Baseline of Font B	21 dots from the top of the character	
Baseline of Font C	16 dots from the top of the character	

Parameter Restrictions

API	Parameter	Specificable Setting Value
Printer	printerSeries	<ul style="list-style-type: none"> Printer.TM_M30II
addTextFont	font	<ul style="list-style-type: none"> Printer.FONT_A (default) Printer.FONT_B Printer.FONT_C Printer.PARAM_DEFAULT
addTextStyle	color	<ul style="list-style-type: none"> Printer.COLOR_1 (default) Printer.PARAM_UNSPECIFIED Printer.PARAM_DEFAULT
addImage	color	<ul style="list-style-type: none"> Printer.COLOR_1 Printer.PARAM_DEFAULT
	mode	<ul style="list-style-type: none"> Printer.MODE_MONO Printer.MODE_MONO_HIGH_DENSITY Printer.PARAM_DEFAULT
addBarcode	font	<ul style="list-style-type: none"> Printer.FONT_A (default) Printer.FONT_B Printer.FONT_C Printer.PARAM_DEFAULT Printer.PARAM_UNSPECIFIED

API	Parameter	Specificable Setting Value
addSymbol	type	<ul style="list-style-type: none"> • Printer.SYMBOL_PDF417_STANDARD • Printer.SYMBOL_PDF417_TRUNCATED • Printer.SYMBOL_QRCODE_MODEL_1 • Printer.SYMBOL_QRCODE_MODEL_2 • Printer.SYMBOL_MAXICODE_MODE_2 • Printer.SYMBOL_MAXICODE_MODE_3 • Printer.SYMBOL_MAXICODE_MODE_4 • Printer.SYMBOL_MAXICODE_MODE_5 • Printer.SYMBOL_MAXICODE_MODE_6 • Printer.SYMBOL_GS1_DATABAR_STACKED • Printer.SYMBOL_GS1_DATABAR_STACKED_OMNIDIRECTIONAL • Printer.SYMBOL_GS1_DATABAR_EXPANDED_STACKED • Printer.SYMBOL_AZTECCODE_FULLRANGE • Printer.SYMBOL_AZTECCODE_COMPACT • Printer.SYMBOL_DATAMATRIX_SQUARE • Printer.SYMBOL_DATAMATRIX_RECTANGLE_8 • Printer.SYMBOL_DATAMATRIX_RECTANGLE_12 • Printer.SYMBOL_DATAMATRIX_RECTANGLE_16
addPageLine	lineStyle	<ul style="list-style-type: none"> • Printer.LINE_THIN • Printer.LINE_MEDIUM • Printer.LINE_THICK • Printer.PARAM_DEFAULT
addPageRectangle	lineStyle	<ul style="list-style-type: none"> • Printer.LINE_THIN • Printer.LINE_MEDIUM • Printer.LINE_THICK • Printer.PARAM_DEFAULT
addCut	type	<ul style="list-style-type: none"> • Printer.CUT_FEED • Printer.CUT_NO_FEED • Printer.PARAM_DEFAULT
addSound	pattern	<ul style="list-style-type: none"> • Printer.PATTERN_NONE • Printer.PATTERN_A • Printer.PATTERN_B • Printer.PATTERN_C • Printer.PATTERN_D • Printer.PATTERN_E • Printer.PATTERN_ERROR • Printer.PATTERN_PAPER_EMPTY • Printer.PARAM_DEFAULT
	repeat	<ul style="list-style-type: none"> • 1 to 255 • Printer.PARAM_DEFAULT

API	Parameter	Specifiable Setting Value
setPrinterSetting	value	<ul style="list-style-type: none"> • Printer.Setting.PaperWidth58_0 • Printer.Setting.PaperWidth80_0 • Printer.Setting.PrintDensity70 • Printer.Setting.PrintDensity75 • Printer.Setting.PrintDensity80 • Printer.Setting.PrintDensity85 • Printer.Setting.PrintDensity90 • Printer.Setting.PrintDensity95 • Printer.Setting.PrintDensity100 • Printer.Setting.PrintDensity105 • Printer.Setting.PrintDensity110 • Printer.Setting.PrintDensity115 • Printer.Setting.PrintDensity120 • Printer.Setting.PrintSpeed1 • Printer.Setting.PrintSpeed2 • Printer.Setting.PrintSpeed3 • Printer.Setting.PrintSpeed4 • Printer.Setting.PrintSpeed5 • Printer.Setting.PrintSpeed6 • Printer.Setting.PrintSpeed7 • Printer.Setting.PrintSpeed8 • Printer.Setting.PrintSpeed9 • Printer.Setting.PrintSpeed10 • Printer.Setting.PrintSpeed11 • Printer.Setting.PrintSpeed12 • Printer.Setting.PrintSpeed13
LineDisplay	displaySeries	<ul style="list-style-type: none"> • LineDisplay.DM_D30

TM-T20**Printer Specifications**

Item	58mm Specification	80mm Specification
Amount of initial feed	30 dots	
Initial page mode area	420 x 831 dots	576 x 831 dots
Maximum page mode area	420 x 1662 dots	576 x 1662 dots
Baseline of Font A	21 dots from the top of the character	
Baseline of Font B	16 dots from the top of the character	

Parameter Restrictions

API	Parameter	Specificable Setting Value
Printer	printerSeries	<ul style="list-style-type: none"> Printer.TM_T20
	lang	<ul style="list-style-type: none"> Printer.MODEL_ANK
addTextLang	lang	<ul style="list-style-type: none"> Printer.LANG_EN (default) Printer.LANG_JA Printer.LANG_ZH_CN Printer.LANG_ZH_TW Printer.LANG_KO Printer.LANG_TH Printer.LANG_VI Printer.PARAM_DEFAULT
addTextFont	font	<ul style="list-style-type: none"> Printer.FONT_A (default) Printer.FONT_B Printer.PARAM_DEFAULT
addTextStyle	color	<ul style="list-style-type: none"> Printer.COLOR_1 (default) Printer.PARAM_UNSPECIFIED Printer.PARAM_DEFAULT
addImage	color	<ul style="list-style-type: none"> Printer.COLOR_1 Printer.PARAM_DEFAULT
	mode	<ul style="list-style-type: none"> Printer.MODE_MONO Printer.MODE_MONO_HIGH_DENSITY Printer.PARAM_DEFAULT
addBarcode	font	<ul style="list-style-type: none"> Printer.FONT_A (default) Printer.FONT_B Printer.PARAM_DEFAULT Printer.PARAM_UNSPECIFIED

API	Parameter	Specificable Setting Value
addSymbol	type	<ul style="list-style-type: none"> • Printer.SYMBOL_PDF417_STANDARD • Printer.SYMBOL_PDF417_TRUNCATED • Printer.SYMBOL_QRCODE_MODEL_1 • Printer.SYMBOL_QRCODE_MODEL_2 • Printer.SYMBOL_MAXICODE_MODE_2 • Printer.SYMBOL_MAXICODE_MODE_3 • Printer.SYMBOL_MAXICODE_MODE_4 • Printer.SYMBOL_MAXICODE_MODE_5 • Printer.SYMBOL_MAXICODE_MODE_6 • Printer.SYMBOL_GS1_DATABAR_STACKED • Printer.SYMBOL_GS1_DATABAR_STACKED_OMNIDIRECTIONAL • Printer.SYMBOL_GS1_DATABAR_EXPANDED_STACKED
	level	<ul style="list-style-type: none"> • Printer.LEVEL_0 • Printer.LEVEL_1 • Printer.LEVEL_2 • Printer.LEVEL_3 • Printer.LEVEL_4 • Printer.LEVEL_5 • Printer.LEVEL_6 • Printer.LEVEL_7 • Printer.LEVEL_8 • Printer.LEVEL_L • Printer.LEVEL_M • Printer.LEVEL_Q • Printer.LEVEL_H • Printer.PARAM_DEFAULT • Printer.PARAM_UNSPECIFIED
addCut	type	<ul style="list-style-type: none"> • Printer.CUT_FEED • Printer.CUT_NO_FEED • Printer.PARAM_DEFAULT
addSound	pattern	<ul style="list-style-type: none"> • Printer.PATTERN_NONE • Printer.PATTERN_A • Printer.PATTERN_B • Printer.PATTERN_C • Printer.PATTERN_D • Printer.PATTERN_E • Printer.PATTERN_ERROR • Printer.PATTERN_PAPER_EMPTY • Printer.PARAM_DEFAULT
	repeat	<ul style="list-style-type: none"> • 1 to 255 • Printer.PARAM_DEFAULT

TM-T20II

Printer Specifications

Item	58mm Specification	80mm Specification
Amount of initial feed	30 dots	
Initial page mode area	420 x 831 dots	576 x 831 dots
Maximum page mode area	420 x 1662 dots	576 x 1662 dots
Baseline of Font A	21 dots from the top of the character	
Baseline of Font B	16 dots from the top of the character	

Parameter Restrictions

API	Parameter	Specificable Setting Value
Printer	printerSeries	<ul style="list-style-type: none"> Printer.TM_T20
	lang	<ul style="list-style-type: none"> Printer.MODEL_ANK
addTextLang	lang	<ul style="list-style-type: none"> Printer.LANG_EN (default) Printer.LANG_JA Printer.LANG_ZH_CN Printer.LANG_ZH_TW Printer.LANG_KO Printer.LANG_TH Printer.LANG_VI Printer.PARAM_DEFAULT
addTextFont	font	<ul style="list-style-type: none"> Printer.FONT_A (default) Printer.FONT_B Printer.PARAM_DEFAULT
addTextStyle	color	<ul style="list-style-type: none"> Printer.COLOR_1 (default) Printer.PARAM_UNSPECIFIED Printer.PARAM_DEFAULT
addImage	color	<ul style="list-style-type: none"> Printer.COLOR_1 Printer.PARAM_DEFAULT
	mode	<ul style="list-style-type: none"> Printer.MODE_MONO Printer.MODE_MONO_HIGH_DENSITY Printer.PARAM_DEFAULT
addBarcode	font	<ul style="list-style-type: none"> Printer.FONT_A (default) Printer.FONT_B Printer.PARAM_DEFAULT Printer.PARAM_UNSPECIFIED

API	Parameter	Specificable Setting Value
addSymbol	type	<ul style="list-style-type: none"> • Printer.SYMBOL_PDF417_STANDARD • Printer.SYMBOL_PDF417_TRUNCATED • Printer.SYMBOL_QRCODE_MODEL_1 • Printer.SYMBOL_QRCODE_MODEL_2 • Printer.SYMBOL_MAXICODE_MODE_2 • Printer.SYMBOL_MAXICODE_MODE_3 • Printer.SYMBOL_MAXICODE_MODE_4 • Printer.SYMBOL_MAXICODE_MODE_5 • Printer.SYMBOL_MAXICODE_MODE_6 • Printer.SYMBOL_GS1_DATABAR_STACKED • Printer.SYMBOL_GS1_DATABAR_STACKED_OMNIDIRECTIONAL • Printer.SYMBOL_GS1_DATABAR_EXPANDED_STACKED
	level	<ul style="list-style-type: none"> • Printer.LEVEL_0 • Printer.LEVEL_1 • Printer.LEVEL_2 • Printer.LEVEL_3 • Printer.LEVEL_4 • Printer.LEVEL_5 • Printer.LEVEL_6 • Printer.LEVEL_7 • Printer.LEVEL_8 • Printer.LEVEL_L • Printer.LEVEL_M • Printer.LEVEL_Q • Printer.LEVEL_H • Printer.PARAM_DEFAULT • Printer.PARAM_UNSPECIFIED
addCut	type	<ul style="list-style-type: none"> • Printer.CUT_FEED • Printer.CUT_NO_FEED • Printer.PARAM_DEFAULT
addSound	pattern	<ul style="list-style-type: none"> • Printer.PATTERN_NONE • Printer.PATTERN_A • Printer.PATTERN_B • Printer.PATTERN_C • Printer.PATTERN_D • Printer.PATTERN_E • Printer.PATTERN_ERROR • Printer.PATTERN_PAPER_EMPTY • Printer.PARAM_DEFAULT
	repeat	<ul style="list-style-type: none"> • 1 to 255 • Printer.PARAM_DEFAULT

API	Parameter	Specifiable Setting Value
getPrinterSetting	type	<ul style="list-style-type: none"> • Printer.Setting.PrintDensity • Printer.Setting.PrintSpeed
setPrinterSetting	type	<ul style="list-style-type: none"> • Printer.Setting.PrintDensity • Printer.Setting.PrintSpeed
	value	<ul style="list-style-type: none"> • Printer.Setting.PrintDensity85 • Printer.Setting.PrintDensity90 • Printer.Setting.PrintDensity95 • Printer.Setting.PrintDensity100 • Printer.Setting.PrintDensity105 • Printer.Setting.PrintDensity110 • Printer.Setting.PrintDensity115 • Printer.Setting.PrintSpeed1 • Printer.Setting.PrintSpeed2 • Printer.Setting.PrintSpeed3 • Printer.Setting.PrintSpeed4 • Printer.Setting.PrintSpeed5 • Printer.Setting.PrintSpeed6 • Printer.Setting.PrintSpeed7 • Printer.Setting.PrintSpeed8 • Printer.Setting.PrintSpeed9 • Printer.Setting.PrintSpeed10 • Printer.Setting.PrintSpeed11 • Printer.Setting.PrintSpeed12 • Printer.Setting.PrintSpeed13

TM-T20III

Printer Specifications

Item		58mm Specification	80mm Specification
Amount of initial feed		30 dots	
Initial page mode area	Standard mode	420 x 1662 dots	576 x 1662 dots
	42 column mode	378 x 1662 dots	546 x 1662 dots
Maximum page mode area	Standard mode	464 x 3324 dots	639 x 3324 dots
	42 column mode	639 x 3324 dots	
Baseline of Font A		21 dots from the top of the character	
Baseline of Font B		16 dots from the top of the character	

Parameter Restrictions

API	Parameter	Specificable Setting Value
Printer	printerSeries	<ul style="list-style-type: none"> Printer.TM_T20
	lang	<ul style="list-style-type: none"> Printer.MODEL_ANK
addTextLang	lang	<ul style="list-style-type: none"> Printer.LANG_EN (default) Printer.LANG_JA Printer.LANG_ZH_CN Printer.LANG_ZH_TW Printer.LANG_KO Printer.LANG_TH Printer.LANG_VI Printer.PARAM_DEFAULT
addTextFont	font	<ul style="list-style-type: none"> Printer.FONT_A (default) Printer.FONT_B Printer.PARAM_DEFAULT
addTextStyle	color	<ul style="list-style-type: none"> Printer.COLOR_1 (default) Printer.PARAM_UNSPECIFIED Printer.PARAM_DEFAULT
addImage	color	<ul style="list-style-type: none"> Printer.COLOR_1 Printer.PARAM_DEFAULT
	mode	<ul style="list-style-type: none"> Printer.MODE_MONO Printer.MODE_MONO_HIGH_DENSITY Printer.PARAM_DEFAULT
addBarcode	font	<ul style="list-style-type: none"> Printer.FONT_A (default) Printer.FONT_B Printer.PARAM_DEFAULT Printer.PARAM_UNSPECIFIED

API	Parameter	Specifiable Setting Value
addSymbol	type	<ul style="list-style-type: none"> • Printer.SYMBOL_PDF417_STANDARD • Printer.SYMBOL_PDF417_TRUNCATED • Printer.SYMBOL_QRCODE_MODEL_1 • Printer.SYMBOL_QRCODE_MODEL_2 • Printer.SYMBOL_MAXICODE_MODE_2 • Printer.SYMBOL_MAXICODE_MODE_3 • Printer.SYMBOL_MAXICODE_MODE_4 • Printer.SYMBOL_MAXICODE_MODE_5 • Printer.SYMBOL_MAXICODE_MODE_6 • Printer.SYMBOL_GS1_DATABAR_STACKED • Printer.SYMBOL_GS1_DATABAR_STACKED_OMNIDIRECTIONAL • Printer.SYMBOL_GS1_DATABAR_EXPANDED_STACKED • Printer.SYMBOL_AZTECCODE_FULLRANGE • Printer.SYMBOL_AZTECCODE_COMPACT • Printer.SYMBOL_DATAMATRIX_SQUARE • Printer.SYMBOL_DATAMATRIX_RECTANGLE_8 • Printer.SYMBOL_DATAMATRIX_RECTANGLE_12 • Printer.SYMBOL_DATAMATRIX_RECTANGLE_16
addCut	type	<ul style="list-style-type: none"> • Printer.CUT_FEED • Printer.CUT_NO_FEED • Printer.PARAM_DEFAULT
addSound	pattern	<ul style="list-style-type: none"> • Printer.PATTERN_NONE • Printer.PATTERN_A • Printer.PATTERN_B • Printer.PATTERN_C • Printer.PATTERN_D • Printer.PATTERN_E • Printer.PATTERN_ERROR • Printer.PATTERN_PAPER_EMPTY • Printer.PARAM_DEFAULT
	repeat	<ul style="list-style-type: none"> • 1 to 255 • Printer.PARAM_DEFAULT

TM-T20III**Printer Specifications**

Item	80mm Specification
Amount of initial feed	30 dots
Initial page mode area	576 x 831 dots
Maximum page mode area	576 x 1662 dots
Baseline of Font A	21 dots from the top of the character
Baseline of Font B	16 dots from the top of the character

Parameter Restrictions

API	Parameter	Specifiable Setting Value
Printer	printerSeries	<ul style="list-style-type: none"> Printer.TM_T20
	lang	<ul style="list-style-type: none"> Printer.MODEL_ANK
addTextLang	lang	<ul style="list-style-type: none"> Printer.LANG_EN (default) Printer.LANG_JA Printer.LANG_ZH_CN Printer.LANG_ZH_TW Printer.LANG_KO Printer.LANG_TH Printer.LANG_VI Printer.PARAM_DEFAULT
addTextFont	font	<ul style="list-style-type: none"> Printer.FONT_A (default) Printer.FONT_B Printer.PARAM_DEFAULT
addTextStyle	color	<ul style="list-style-type: none"> Printer.COLOR_1 (default) Printer.PARAM_UNSPECIFIED Printer.PARAM_DEFAULT
addImage	color	<ul style="list-style-type: none"> Printer.COLOR_1 Printer.PARAM_DEFAULT
	mode	<ul style="list-style-type: none"> Printer.MODE_MONO Printer.MODE_MONO_HIGH_DENSITY Printer.PARAM_DEFAULT
addBarcode	font	<ul style="list-style-type: none"> Printer.FONT_A (default) Printer.FONT_B Printer.PARAM_DEFAULT Printer.PARAM_UNSPECIFIED

API	Parameter	Specificable Setting Value
addSymbol	type	<ul style="list-style-type: none"> • Printer.SYMBOL_PDF417_STANDARD • Printer.SYMBOL_PDF417_TRUNCATED • Printer.SYMBOL_QRCODE_MODEL_1 • Printer.SYMBOL_QRCODE_MODEL_2 • Printer.SYMBOL_MAXICODE_MODE_2 • Printer.SYMBOL_MAXICODE_MODE_3 • Printer.SYMBOL_MAXICODE_MODE_4 • Printer.SYMBOL_MAXICODE_MODE_5 • Printer.SYMBOL_MAXICODE_MODE_6 • Printer.SYMBOL_GS1_DATABAR_STACKED • Printer.SYMBOL_GS1_DATABAR_STACKED_OMNIDIRECTIONAL • Printer.SYMBOL_GS1_DATABAR_EXPANDED_STACKED
	level	<ul style="list-style-type: none"> • Printer.LEVEL_0 • Printer.LEVEL_1 • Printer.LEVEL_2 • Printer.LEVEL_3 • Printer.LEVEL_4 • Printer.LEVEL_5 • Printer.LEVEL_6 • Printer.LEVEL_7 • Printer.LEVEL_8 • Printer.LEVEL_L • Printer.LEVEL_M • Printer.LEVEL_Q • Printer.LEVEL_H • Printer.PARAM_DEFAULT • Printer.PARAM_UNSPECIFIED
addCut	type	<ul style="list-style-type: none"> • Printer.CUT_FEED • Printer.CUT_NO_FEED • Printer.PARAM_DEFAULT
addSound	pattern	<ul style="list-style-type: none"> • Printer.PATTERN_NONE • Printer.PATTERN_A • Printer.PATTERN_B • Printer.PATTERN_C • Printer.PATTERN_D • Printer.PATTERN_E • Printer.PATTERN_ERROR • Printer.PATTERN_PAPER_EMPTY • Printer.PARAM_DEFAULT
	repeat	<ul style="list-style-type: none"> • 1 to 255 • Printer.PARAM_DEFAULT

TM-T20X**Printer Specifications**

Item	80mm Specification
Amount of initial feed	30 dots
Initial page mode area	576 x 831 dots
Maximum page mode area	576 x 1662 dots
Baseline of Font A	21 dots from the top of the character
Baseline of Font B	16 dots from the top of the character

Parameter Restrictions

API	Parameter	Specifiable Setting Value
Printer	printerSeries	<ul style="list-style-type: none"> Printer.TM_T20
	lang	<ul style="list-style-type: none"> Printer.MODEL_ANK
addTextLang	lang	<ul style="list-style-type: none"> Printer.LANG_EN (default) Printer.LANG_JA Printer.LANG_ZH_CN Printer.LANG_ZH_TW Printer.LANG_KO Printer.LANG_TH Printer.LANG_VI Printer.PARAM_DEFAULT
addTextFont	font	<ul style="list-style-type: none"> Printer.FONT_A (default) Printer.FONT_B Printer.PARAM_DEFAULT
addTextStyle	color	<ul style="list-style-type: none"> Printer.COLOR_1 (default) Printer.PARAM_UNSPECIFIED Printer.PARAM_DEFAULT
addImage	color	<ul style="list-style-type: none"> Printer.COLOR_1 Printer.PARAM_DEFAULT
	mode	<ul style="list-style-type: none"> Printer.MODE_MONO Printer.MODE_MONO_HIGH_DENSITY Printer.PARAM_DEFAULT
addBarcode	font	<ul style="list-style-type: none"> Printer.FONT_A (default) Printer.FONT_B Printer.PARAM_DEFAULT Printer.PARAM_UNSPECIFIED

API	Parameter	Specificable Setting Value
addSymbol	type	<ul style="list-style-type: none"> • Printer.SYMBOL_PDF417_STANDARD • Printer.SYMBOL_PDF417_TRUNCATED • Printer.SYMBOL_QRCODE_MODEL_1 • Printer.SYMBOL_QRCODE_MODEL_2 • Printer.SYMBOL_MAXICODE_MODE_2 • Printer.SYMBOL_MAXICODE_MODE_3 • Printer.SYMBOL_MAXICODE_MODE_4 • Printer.SYMBOL_MAXICODE_MODE_5 • Printer.SYMBOL_MAXICODE_MODE_6 • Printer.SYMBOL_GS1_DATABAR_STACKED • Printer.SYMBOL_GS1_DATABAR_STACKED_OMNIDIRECTIONAL • Printer.SYMBOL_GS1_DATABAR_EXPANDED_STACKED
	level	<ul style="list-style-type: none"> • Printer.LEVEL_0 • Printer.LEVEL_1 • Printer.LEVEL_2 • Printer.LEVEL_3 • Printer.LEVEL_4 • Printer.LEVEL_5 • Printer.LEVEL_6 • Printer.LEVEL_7 • Printer.LEVEL_8 • Printer.LEVEL_L • Printer.LEVEL_M • Printer.LEVEL_Q • Printer.LEVEL_H • Printer.PARAM_DEFAULT • Printer.PARAM_UNSPECIFIED
addCut	type	<ul style="list-style-type: none"> • Printer.CUT_FEED • Printer.CUT_NO_FEED • Printer.PARAM_DEFAULT
addSound	pattern	<ul style="list-style-type: none"> • Printer.PATTERN_NONE • Printer.PATTERN_A • Printer.PATTERN_B • Printer.PATTERN_C • Printer.PATTERN_D • Printer.PATTERN_E • Printer.PATTERN_ERROR • Printer.PATTERN_PAPER_EMPTY • Printer.PARAM_DEFAULT
	repeat	<ul style="list-style-type: none"> • 1 to 255 • Printer.PARAM_DEFAULT

TM-T60**Printer Specifications**

Item	58mm Specification
Amount of initial feed	30 dots
Initial page mode area	576 x 831 dots
Maximum page mode area	576 x 1662 dots
Baseline of Font A	21 dots from the top of the character
Baseline of Font B	16 dots from the top of the character

Parameter Restrictions

API	Parameter	Specifiable Setting Value
Printer	printerSeries	<ul style="list-style-type: none"> Printer.TM_T60
	lang	<ul style="list-style-type: none"> Printer.MODEL_CHINESE
addTextLang	lang	<ul style="list-style-type: none"> Printer.LANG_EN (default) Printer.LANG_JA Printer.LANG_ZH_CN Printer.LANG_ZH_TW Printer.LANG_KO Printer.LANG_TH Printer.LANG_VI Printer.PARAM_DEFAULT
addTextFont	font	<ul style="list-style-type: none"> Printer.FONT_A (default) Printer.FONT_B Printer.PARAM_DEFAULT
addTextStyle	color	<ul style="list-style-type: none"> Printer.COLOR_1 (default) Printer.PARAM_UNSPECIFIED Printer.PARAM_DEFAULT
addImage	color	<ul style="list-style-type: none"> Printer.COLOR_1 Printer.PARAM_DEFAULT
	mode	<ul style="list-style-type: none"> Printer.MODE_MONO Printer.MODE_MONO_HIGH_DENSITY Printer.PARAM_DEFAULT

API	Parameter	Specifiable Setting Value
addBarcode	type	<ul style="list-style-type: none"> • Printer.BARCODE_UPC_A • Printer.BARCODE_UPC_E • Printer.BARCODE_EAN13 • Printer.BARCODE_JAN13 • Printer.BARCODE_EAN8 • Printer.BARCODE_JAN8 • Printer.BARCODE_CODE39 • Printer.BARCODE_ITF • Printer.BARCODE_CODABAR • Printer.BARCODE_CODE93 • Printer.BARCODE_CODE128
	font	<ul style="list-style-type: none"> • Printer.FONT_A (default) • Printer.FONT_B • Printer.PARAM_DEFAULT • Printer.PARAM_UNSPECIFIED
addSymbol	type	<ul style="list-style-type: none"> • Printer.SYMBOL_PDF417_STANDARD • Printer.SYMBOL_PDF417_TRUNCATED • Printer.SYMBOL_QRCODE_MODEL_1 • Printer.SYMBOL_QRCODE_MODEL_2
	level	<ul style="list-style-type: none"> • Printer.LEVEL_0 • Printer.LEVEL_1 • Printer.LEVEL_2 • Printer.LEVEL_3 • Printer.LEVEL_4 • Printer.LEVEL_5 • Printer.LEVEL_6 • Printer.LEVEL_7 • Printer.LEVEL_8 • Printer.LEVEL_L • Printer.LEVEL_M • Printer.LEVEL_Q • Printer.LEVEL_H • Printer.PARAM_DEFAULT • Printer.PARAM_UNSPECIFIED
addCut	type	<ul style="list-style-type: none"> • Printer.CUT_FEED • Printer.CUT_NO_FEED • Printer.PARAM_DEFAULT

TM-T70**Printer Specifications**

Item		58mm Specification	80mm Specification
Amount of initial feed		30 dots	
Initial page mode area	ANK model	416 x 1662 dots	512 x 831 dots
	Multiple languages model	416 x 1662 dots	576 x 1662 dots
Maximum page mode area	ANK model	416 x 1662 dots	512 x 1662 dots
	Multiple languages model	576 x 1662 dots	
Baseline of Font A		21 dots from the top of the character	
Baseline of Font B		16 dots from the top of the character	

Parameter Restrictions

API	Parameter	Specificable Setting Value
Printer	printerSeries	<ul style="list-style-type: none"> Printer.TM_T70
	lang	<ul style="list-style-type: none"> Printer.MODEL_ANK Printer.MODEL_CHINESE Printer.MODEL_TAIWAN
addTextLang	lang	<ul style="list-style-type: none"> Printer.LANG_EN (default) Printer.LANG_JA Printer.LANG_ZH_CN Printer.LANG_ZH_TW Printer.LANG_KO Printer.LANG_TH Printer.LANG_VI Printer.PARAM_DEFAULT
addTextFont	font	<ul style="list-style-type: none"> Printer.FONT_A (default) Printer.FONT_B Printer.PARAM_DEFAULT
addTextStyle	color	<ul style="list-style-type: none"> Printer.COLOR_1 (default) Printer.PARAM_UNSPECIFIED Printer.PARAM_DEFAULT
addImage	color	<ul style="list-style-type: none"> Printer.COLOR_1 Printer.PARAM_DEFAULT
	mode	<ul style="list-style-type: none"> Printer.MODE_MONO Printer.MODE_MONO_HIGH_DENSITY Printer.PARAM_DEFAULT

API	Parameter	Specifiable Setting Value
addBarcode	type	<ul style="list-style-type: none"> • Printer.BARCODE_UPC_A • Printer.BARCODE_UPC_E • Printer.BARCODE_EAN13 • Printer.BARCODE_JAN13 • Printer.BARCODE_EAN8 • Printer.BARCODE_JAN8 • Printer.BARCODE_CODE39 • Printer.BARCODE_ITF • Printer.BARCODE_CODABAR • Printer.BARCODE_CODE93 • Printer.BARCODE_CODE128
	font	<ul style="list-style-type: none"> • Printer.FONT_A (default) • Printer.FONT_B • Printer.PARAM_DEFAULT • Printer.PARAM_UNSPECIFIED
addSymbol	type	<ul style="list-style-type: none"> • Printer.SYMBOL_PDF417_STANDARD • Printer.SYMBOL_PDF417_TRUNCATED • Printer.SYMBOL_QRCODE_MODEL_1 • Printer.SYMBOL_QRCODE_MODEL_2
	level	<ul style="list-style-type: none"> • Printer.LEVEL_0 • Printer.LEVEL_1 • Printer.LEVEL_2 • Printer.LEVEL_3 • Printer.LEVEL_4 • Printer.LEVEL_5 • Printer.LEVEL_6 • Printer.LEVEL_7 • Printer.LEVEL_8 • Printer.LEVEL_L • Printer.LEVEL_M • Printer.LEVEL_Q • Printer.LEVEL_H • Printer.PARAM_DEFAULT • Printer.PARAM_UNSPECIFIED
addCut	type	<ul style="list-style-type: none"> • Printer.CUT_FEED • Printer.CUT_NO_FEED • Printer.PARAM_DEFAULT

TM-T70II**Printer Specifications**

Item		58mm Specification	80mm Specification
Amount of initial feed		30 dots	
Initial page mode area	ANK model	416 x 1662 dots	512 x 1662 dots
	Multiple languages model	416 x 1662 dots	576 x 1662 dots
Maximum page mode area	ANK model	416 x 1662 dots	512 x 1662 dots
	Multiple languages model	576 x 1662 dots	
Baseline of Font A		21 dots from the top of the character	
Baseline of Font B		16 dots from the top of the character	

Parameter Restrictions

API	Parameter	Specificable Setting Value
Printer	printerSeries	<ul style="list-style-type: none"> Printer.TM_T70
	lang	<ul style="list-style-type: none"> Printer.MODEL_ANK Printer.MODEL_CHINESE Printer.MODEL_TAIWAN Printer.MODEL_SOUTHASIA
addTextLang	lang	<ul style="list-style-type: none"> Printer.LANG_EN (default) Printer.LANG_JA Printer.LANG_ZH_CN Printer.LANG_ZH_TW Printer.LANG_KO Printer.LANG_TH Printer.LANG_VI Printer.PARAM_DEFAULT
addTextFont	font	<ul style="list-style-type: none"> Printer.FONT_A (default) Printer.FONT_B Printer.PARAM_DEFAULT
addTextStyle	color	<ul style="list-style-type: none"> Printer.COLOR_1 (default) Printer.PARAM_UNSPECIFIED Printer.PARAM_DEFAULT
addImage	color	<ul style="list-style-type: none"> Printer.COLOR_1 Printer.PARAM_DEFAULT
	mode	<ul style="list-style-type: none"> Printer.MODE_MONO Printer.MODE_MONO_HIGH_DENSITY Printer.PARAM_DEFAULT

API	Parameter	Specifiable Setting Value
addBarcode	font	<ul style="list-style-type: none"> • Printer.FONT_A (default) • Printer.FONT_B • Printer.PARAM_DEFAULT • Printer.PARAM_UNSPECIFIED
addSymbol	type	<ul style="list-style-type: none"> • Printer.SYMBOL_PDF417_STANDARD • Printer.SYMBOL_PDF417_TRUNCATED • Printer.SYMBOL_QRCODE_MODEL_1 • Printer.SYMBOL_QRCODE_MODEL_2 • Printer.SYMBOL_MAXICODE_MODE_2 • Printer.SYMBOL_MAXICODE_MODE_3 • Printer.SYMBOL_MAXICODE_MODE_4 • Printer.SYMBOL_MAXICODE_MODE_5 • Printer.SYMBOL_MAXICODE_MODE_6 • Printer.SYMBOL_GS1_DATABAR_STACKED • Printer.SYMBOL_GS1_DATABAR_STACKED_OMNIDIRECTIONAL • Printer.SYMBOL_GS1_DATABAR_EXPANDED_STACKED
	level	<ul style="list-style-type: none"> • Printer.LEVEL_0 • Printer.LEVEL_1 • Printer.LEVEL_2 • Printer.LEVEL_3 • Printer.LEVEL_4 • Printer.LEVEL_5 • Printer.LEVEL_6 • Printer.LEVEL_7 • Printer.LEVEL_8 • Printer.LEVEL_L • Printer.LEVEL_M • Printer.LEVEL_Q • Printer.LEVEL_H • Printer.PARAM_DEFAULT • Printer.PARAM_UNSPECIFIED
addCut	type	<ul style="list-style-type: none"> • Printer.CUT_FEED • Printer.CUT_NO_FEED • Printer.PARAM_DEFAULT

API	Parameter	Specifiable Setting Value
addSound	pattern	<ul style="list-style-type: none"> • Printer.PATTERN_NONE • Printer.PATTERN_A • Printer.PATTERN_B • Printer.PATTERN_C • Printer.PATTERN_D • Printer.PATTERN_E • Printer.PATTERN_ERROR • Printer.PATTERN_PAPER_EMPTY • Printer.PARAM_DEFAULT
	repeat	<ul style="list-style-type: none"> • 1 to 255 • Printer.PARAM_DEFAULT

TM-T81II**Printer Specifications**

Item	58mm Specification
Amount of initial feed	30 dots
Initial page mode area	576 x 831 dots
Maximum page mode area	576 x 1662 dots
Baseline of Font A	21 dots from the top of the character
Baseline of Font B	16 dots from the top of the character

Parameter Restrictions

API	Parameter	Specificable Setting Value
Printer	printerSeries	<ul style="list-style-type: none"> Printer.TM_T81
	lang	<ul style="list-style-type: none"> Printer.MODEL_CHINESE Printer.MODEL_SOUTHASIA
addTextLang	lang	<ul style="list-style-type: none"> Printer.LANG_EN (default) Printer.LANG_JA Printer.LANG_ZH_CN Printer.LANG_ZH_TW Printer.LANG_KO Printer.LANG_TH Printer.LANG_VI Printer.PARAM_DEFAULT
addTextFont	font	<ul style="list-style-type: none"> Printer.FONT_A (default) Printer.FONT_B Printer.PARAM_DEFAULT
addTextStyle	color	<ul style="list-style-type: none"> Printer.COLOR_1 (default) Printer.PARAM_UNSPECIFIED Printer.PARAM_DEFAULT
addImage	color	<ul style="list-style-type: none"> Printer.COLOR_1 Printer.PARAM_DEFAULT
	mode	<ul style="list-style-type: none"> Printer.MODE_MONO Printer.MODE_MONO_HIGH_DENSITY Printer.PARAM_DEFAULT

API	Parameter	Specifiable Setting Value
addBarcode	type	<ul style="list-style-type: none"> • Printer.BARCODE_UPC_A • Printer.BARCODE_UPC_E • Printer.BARCODE_EAN13 • Printer.BARCODE_JAN13 • Printer.BARCODE_EAN8 • Printer.BARCODE_JAN8 • Printer.BARCODE_CODE39 • Printer.BARCODE_ITF • Printer.BARCODE_CODABAR • Printer.BARCODE_CODE93 • Printer.BARCODE_CODE128
	font	<ul style="list-style-type: none"> • Printer.FONT_A (default) • Printer.FONT_B • Printer.PARAM_DEFAULT • Printer.PARAM_UNSPECIFIED
addSymbol	type	<ul style="list-style-type: none"> • Printer.SYMBOL_PDF417_STANDARD • Printer.SYMBOL_PDF417_TRUNCATED • Printer.SYMBOL_QRCODE_MODEL_1 • Printer.SYMBOL_QRCODE_MODEL_2
	level	<ul style="list-style-type: none"> • Printer.LEVEL_0 • Printer.LEVEL_1 • Printer.LEVEL_2 • Printer.LEVEL_3 • Printer.LEVEL_4 • Printer.LEVEL_5 • Printer.LEVEL_6 • Printer.LEVEL_7 • Printer.LEVEL_8 • Printer.LEVEL_L • Printer.LEVEL_M • Printer.LEVEL_Q • Printer.LEVEL_H • Printer.PARAM_DEFAULT • Printer.PARAM_UNSPECIFIED
addCut	type	<ul style="list-style-type: none"> • Printer.CUT_FEED • Printer.CUT_NO_FEED • Printer.PARAM_DEFAULT

TM-T81III**Printer Specifications**

Item	80mm Specification
Amount of initial feed	30 dots
Initial page mode area	576 x 831 dots
Maximum page mode area	576 x 1662 dots
Baseline of Font A	21 dots from the top of the character
Baseline of Font B	16 dots from the top of the character

Parameter Restrictions

API	Parameter	Specifiable Setting Value
Printer	printerSeries	<ul style="list-style-type: none"> • Printer.TM_T81
	lang	<ul style="list-style-type: none"> • Printer.MODEL_ANK • Printer.MODEL_CHINESE • Printer.MODEL_SOUTHASIA
addTextLang	lang	<ul style="list-style-type: none"> • Printer.LANG_EN (default) • Printer.LANG_JA • Printer.LANG_ZH_CN • Printer.LANG_ZH_TW • Printer.LANG_KO • Printer.LANG_TH • Printer.LANG_VI • Printer.PARAM_DEFAULT
addTextFont	font	<ul style="list-style-type: none"> • Printer.FONT_A (default) • Printer.FONT_B • Printer.PARAM_DEFAULT
addTextStyle	color	<ul style="list-style-type: none"> • Printer.COLOR_1 (default) • Printer.PARAM_UNSPECIFIED • Printer.PARAM_DEFAULT
addImage	color	<ul style="list-style-type: none"> • Printer.COLOR_1 • Printer.PARAM_DEFAULT
	mode	<ul style="list-style-type: none"> • Printer.MODE_MONO • Printer.MODE_MONO_HIGH_DENSITY • Printer.PARAM_DEFAULT
addBarcode	font	<ul style="list-style-type: none"> • Printer.FONT_A (default) • Printer.FONT_B • Printer.PARAM_DEFAULT • Printer.PARAM_UNSPECIFIED

API	Parameter	Specificable Setting Value
addSymbol	type	<ul style="list-style-type: none"> • Printer.SYMBOL_PDF417_STANDARD • Printer.SYMBOL_PDF417_TRUNCATED • Printer.SYMBOL_QRCODE_MODEL_1 • Printer.SYMBOL_QRCODE_MODEL_2 • Printer.SYMBOL_MAXICODE_MODE_2 • Printer.SYMBOL_MAXICODE_MODE_3 • Printer.SYMBOL_MAXICODE_MODE_4 • Printer.SYMBOL_MAXICODE_MODE_5 • Printer.SYMBOL_MAXICODE_MODE_6 • Printer.SYMBOL_GS1_DATABAR_STACKED • Printer.SYMBOL_GS1_DATABAR_STACKED_OMNIDIRECTIONAL • Printer.SYMBOL_GS1_DATABAR_EXPANDED_STACKED
	level	<ul style="list-style-type: none"> • Printer.LEVEL_0 • Printer.LEVEL_1 • Printer.LEVEL_2 • Printer.LEVEL_3 • Printer.LEVEL_4 • Printer.LEVEL_5 • Printer.LEVEL_6 • Printer.LEVEL_7 • Printer.LEVEL_8 • Printer.LEVEL_L • Printer.LEVEL_M • Printer.LEVEL_Q • Printer.LEVEL_H • Printer.PARAM_DEFAULT • Printer.PARAM_UNSPECIFIED
addCut	type	<ul style="list-style-type: none"> • Printer.CUT_FEED • Printer.CUT_NO_FEED • Printer.PARAM_DEFAULT
addSound	pattern	<ul style="list-style-type: none"> • Printer.PATTERN_NONE • Printer.PATTERN_A • Printer.PATTERN_B • Printer.PATTERN_C • Printer.PATTERN_D • Printer.PATTERN_E • Printer.PATTERN_ERROR • Printer.PATTERN_PAPER_EMPTY • Printer.PARAM_DEFAULT
	repeat	<ul style="list-style-type: none"> • 1 to 255 • Printer.PARAM_DEFAULT

TM-T82**Printer Specifications**

Item	58mm Specification	80mm Specification
Amount of initial feed	30 dots	
Initial page mode area	420 x 831 dots	576 x 831 dots
Maximum page mode area	420 x 1662 dots	576 x 1662 dots
Baseline of Font A	21 dots from the top of the character	
Baseline of Font B	16 dots from the top of the character	

Parameter Restrictions

API	Parameter	Specifiable Setting Value
Printer	printerSeries	<ul style="list-style-type: none"> Printer.TM_T82
	lang	<ul style="list-style-type: none"> Printer.MODEL_CHINESE Printer.MODEL_SOUTHASIA
addTextLang	lang	<ul style="list-style-type: none"> Printer.LANG_EN (default) Printer.LANG_JA Printer.LANG_ZH_CN Printer.LANG_ZH_TW Printer.LANG_KO Printer.LANG_TH Printer.LANG_VI Printer.PARAM_DEFAULT
addTextFont	font	<ul style="list-style-type: none"> Printer.FONT_A (default) Printer.FONT_B Printer.PARAM_DEFAULT
addTextStyle	color	<ul style="list-style-type: none"> Printer.COLOR_1 (default) Printer.PARAM_UNSPECIFIED Printer.PARAM_DEFAULT
addImage	color	<ul style="list-style-type: none"> Printer.COLOR_1 Printer.PARAM_DEFAULT
	mode	<ul style="list-style-type: none"> Printer.MODE_MONO Printer.MODE_MONO_HIGH_DENSITY Printer.PARAM_DEFAULT
addBarcode	font	<ul style="list-style-type: none"> Printer.FONT_A (default) Printer.FONT_B Printer.PARAM_DEFAULT Printer.PARAM_UNSPECIFIED

API	Parameter	Specificable Setting Value
addSymbol	type	<ul style="list-style-type: none"> • Printer.SYMBOL_PDF417_STANDARD • Printer.SYMBOL_PDF417_TRUNCATED • Printer.SYMBOL_QRCODE_MODEL_1 • Printer.SYMBOL_QRCODE_MODEL_2 • Printer.SYMBOL_MAXICODE_MODE_2 • Printer.SYMBOL_MAXICODE_MODE_3 • Printer.SYMBOL_MAXICODE_MODE_4 • Printer.SYMBOL_MAXICODE_MODE_5 • Printer.SYMBOL_MAXICODE_MODE_6 • Printer.SYMBOL_GS1_DATABAR_STACKED • Printer.SYMBOL_GS1_DATABAR_STACKED_OMNIDIRECTIONAL • Printer.SYMBOL_GS1_DATABAR_EXPANDED_STACKED
	level	<ul style="list-style-type: none"> • Printer.LEVEL_0 • Printer.LEVEL_1 • Printer.LEVEL_2 • Printer.LEVEL_3 • Printer.LEVEL_4 • Printer.LEVEL_5 • Printer.LEVEL_6 • Printer.LEVEL_7 • Printer.LEVEL_8 • Printer.LEVEL_L • Printer.LEVEL_M • Printer.LEVEL_Q • Printer.LEVEL_H • Printer.PARAM_DEFAULT • Printer.PARAM_UNSPECIFIED
addCut	type	<ul style="list-style-type: none"> • Printer.CUT_FEED • Printer.CUT_NO_FEED • Printer.PARAM_DEFAULT
addSound	pattern	<ul style="list-style-type: none"> • Printer.PATTERN_NONE • Printer.PATTERN_A • Printer.PATTERN_B • Printer.PATTERN_C • Printer.PATTERN_D • Printer.PATTERN_E • Printer.PATTERN_ERROR • Printer.PATTERN_PAPER_EMPTY • Printer.PARAM_DEFAULT
	repeat	<ul style="list-style-type: none"> • 1 to 255 • Printer.PARAM_DEFAULT

TM-T82II

Printer Specifications

Item	Specification
Amount of initial feed	30 dots
Initial page mode area	576 x 831 dots
Maximum page mode area	576 x 1662 dots
Baseline of Font A	21 dots from the top of the character
Baseline of Font B	16 dots from the top of the character

Parameter Restrictions

API	Parameter	Specificable Setting Value
Printer	printerSeries	<ul style="list-style-type: none"> Printer.TM_T82
	lang	<ul style="list-style-type: none"> Printer.MODEL_ANK Printer.MODEL_CHINESE Printer.MODEL_TAIWAN Printer.MODEL_SOUTHASIA
addTextLang	lang	<ul style="list-style-type: none"> Printer.LANG_EN (default) Printer.LANG_JA Printer.LANG_ZH_CN Printer.LANG_ZH_TW Printer.LANG_KO Printer.LANG_TH Printer.LANG_VI Printer.PARAM_DEFAULT
addTextFont	font	<ul style="list-style-type: none"> Printer.FONT_A (default) Printer.FONT_B Printer.PARAM_DEFAULT
addTextStyle	color	<ul style="list-style-type: none"> Printer.COLOR_1 (default) Printer.PARAM_UNSPECIFIED Printer.PARAM_DEFAULT
addImage	color	<ul style="list-style-type: none"> Printer.COLOR_1 Printer.PARAM_DEFAULT
	mode	<ul style="list-style-type: none"> Printer.MODE_MONO Printer.MODE_MONO_HIGH_DENSITY Printer.PARAM_DEFAULT
addBarcode	font	<ul style="list-style-type: none"> Printer.FONT_A (default) Printer.FONT_B Printer.PARAM_DEFAULT Printer.PARAM_UNSPECIFIED

API	Parameter	Specificable Setting Value
addSymbol	type	<ul style="list-style-type: none"> • Printer.SYMBOL_PDF417_STANDARD • Printer.SYMBOL_PDF417_TRUNCATED • Printer.SYMBOL_QRCODE_MODEL_1 • Printer.SYMBOL_QRCODE_MODEL_2 • Printer.SYMBOL_MAXICODE_MODE_2 • Printer.SYMBOL_MAXICODE_MODE_3 • Printer.SYMBOL_MAXICODE_MODE_4 • Printer.SYMBOL_MAXICODE_MODE_5 • Printer.SYMBOL_MAXICODE_MODE_6 • Printer.SYMBOL_GS1_DATABAR_STACKED • Printer.SYMBOL_GS1_DATABAR_STACKED_OMNIDIRECTIONAL • Printer.SYMBOL_GS1_DATABAR_EXPANDED_STACKED
	level	<ul style="list-style-type: none"> • Printer.LEVEL_0 • Printer.LEVEL_1 • Printer.LEVEL_2 • Printer.LEVEL_3 • Printer.LEVEL_4 • Printer.LEVEL_5 • Printer.LEVEL_6 • Printer.LEVEL_7 • Printer.LEVEL_8 • Printer.LEVEL_L • Printer.LEVEL_M • Printer.LEVEL_Q • Printer.LEVEL_H • Printer.PARAM_DEFAULT • Printer.PARAM_UNSPECIFIED
addCut	type	<ul style="list-style-type: none"> • Printer.CUT_FEED • Printer.CUT_NO_FEED • Printer.PARAM_DEFAULT
addSound	pattern	<ul style="list-style-type: none"> • Printer.PATTERN_NONE • Printer.PATTERN_A • Printer.PATTERN_B • Printer.PATTERN_C • Printer.PATTERN_D • Printer.PATTERN_E • Printer.PATTERN_ERROR • Printer.PATTERN_PAPER_EMPTY • Printer.PARAM_DEFAULT
	repeat	<ul style="list-style-type: none"> • 1 to 255 • Printer.PARAM_DEFAULT

TM-T82III**Printer Specifications**

Item		58mm Specification	80mm Specification
Amount of initial feed		30 dots	
Initial page mode area	Standerd mode	420 x 1662 dots	576 x 1662 dots
	42 column mode	378 x 1662 dots	546 x 1662 dots
Maximum page mode area	Standerd mode	464 x 3324 dots	639 x 3324 dots
	42 column mode	639 x 3324 dots	
Baseline of Font A		21 dots from the top of the character	
Baseline of Font B		16 dots from the top of the character	

Parameter Restrictions

API	Parameter	Specificable Setting Value
Printer	printerSeries	<ul style="list-style-type: none"> Printer.TM_T82
	lang	<ul style="list-style-type: none"> Printer.MODEL_ANK Printer.MODEL_CHINESE Printer.MODEL_TAIWAN
addTextLang	lang	<ul style="list-style-type: none"> Printer.LANG_EN (default) Printer.LANG_JA Printer.LANG_ZH_CN Printer.LANG_ZH_TW Printer.LANG_KO Printer.LANG_TH Printer.LANG_VI Printer.PARAM_DEFAULT
addTextFont	font	<ul style="list-style-type: none"> Printer.FONT_A (default) Printer.FONT_B Printer.PARAM_DEFAULT
addTextStyle	color	<ul style="list-style-type: none"> Printer.COLOR_1 (default) Printer.PARAM_UNSPECIFIED Printer.PARAM_DEFAULT
addImage	color	<ul style="list-style-type: none"> Printer.COLOR_1 Printer.PARAM_DEFAULT
	mode	<ul style="list-style-type: none"> Printer.MODE_MONO Printer.MODE_MONO_HIGH_DENSITY Printer.PARAM_DEFAULT

API	Parameter	Specifiable Setting Value
addBarcode	font	<ul style="list-style-type: none"> • Printer.FONT_A (default) • Printer.FONT_B • Printer.PARAM_DEFAULT • Printer.PARAM_UNSPECIFIED
addSymbol	type	<ul style="list-style-type: none"> • Printer.SYMBOL_PDF417_STANDARD • Printer.SYMBOL_PDF417_TRUNCATED • Printer.SYMBOL_QRCODE_MODEL_1 • Printer.SYMBOL_QRCODE_MODEL_2 • Printer.SYMBOL_MAXICODE_MODE_2 • Printer.SYMBOL_MAXICODE_MODE_3 • Printer.SYMBOL_MAXICODE_MODE_4 • Printer.SYMBOL_MAXICODE_MODE_5 • Printer.SYMBOL_MAXICODE_MODE_6 • Printer.SYMBOL_GS1_DATABAR_STACKED • Printer.SYMBOL_GS1_DATABAR_STACKED_OMNIDIRECTIONAL • Printer.SYMBOL_GS1_DATABAR_EXPANDED_STACKED • Printer.SYMBOL_AZTECCODE_FULLRANGE • Printer.SYMBOL_AZTECCODE_COMPACT • Printer.SYMBOL_DATAMATRIX_SQUARE • Printer.SYMBOL_DATAMATRIX_RECTANGLE_8 • Printer.SYMBOL_DATAMATRIX_RECTANGLE_12 • Printer.SYMBOL_DATAMATRIX_RECTANGLE_16
addCut	type	<ul style="list-style-type: none"> • Printer.CUT_FEED • Printer.CUT_NO_FEED • Printer.PARAM_DEFAULT
addSound	pattern	<ul style="list-style-type: none"> • Printer.PATTERN_NONE • Printer.PATTERN_A • Printer.PATTERN_B • Printer.PATTERN_C • Printer.PATTERN_D • Printer.PATTERN_E • Printer.PATTERN_ERROR • Printer.PATTERN_PAPER_EMPTY • Printer.PARAM_DEFAULT
	repeat	<ul style="list-style-type: none"> • 1 to 255 • Printer.PARAM_DEFAULT

TM-T82IIIL**Printer Specifications**

Item	80mm Specification
Amount of initial feed	30 dots
Initial page mode area	576 x 831 dots
Maximum page mode area	576 x 1662 dots
Baseline of Font A	21 dots from the top of the character
Baseline of Font B	16 dots from the top of the character

Parameter Restrictions

API	Parameter	Specifiable Setting Value
Printer	printerSeries	<ul style="list-style-type: none"> Printer.TM_T82
	lang	<ul style="list-style-type: none"> Printer.MODEL_ANK
addTextLang	lang	<ul style="list-style-type: none"> Printer.LANG_EN (default) Printer.LANG_JA Printer.LANG_ZH_CN Printer.LANG_ZH_TW Printer.LANG_KO Printer.LANG_TH Printer.LANG_VI Printer.PARAM_DEFAULT
addTextFont	font	<ul style="list-style-type: none"> Printer.FONT_A (default) Printer.FONT_B Printer.PARAM_DEFAULT
addTextStyle	color	<ul style="list-style-type: none"> Printer.COLOR_1 (default) Printer.PARAM_UNSPECIFIED Printer.PARAM_DEFAULT
addImage	color	<ul style="list-style-type: none"> Printer.COLOR_1 Printer.PARAM_DEFAULT
	mode	<ul style="list-style-type: none"> Printer.MODE_MONO Printer.MODE_MONO_HIGH_DENSITY Printer.PARAM_DEFAULT
addBarcode	font	<ul style="list-style-type: none"> Printer.FONT_A (default) Printer.FONT_B Printer.PARAM_DEFAULT Printer.PARAM_UNSPECIFIED

API	Parameter	Specifiable Setting Value
addSymbol	type	<ul style="list-style-type: none"> • Printer.SYMBOL_PDF417_STANDARD • Printer.SYMBOL_PDF417_TRUNCATED • Printer.SYMBOL_QRCODE_MODEL_1 • Printer.SYMBOL_QRCODE_MODEL_2 • Printer.SYMBOL_MAXICODE_MODE_2 • Printer.SYMBOL_MAXICODE_MODE_3 • Printer.SYMBOL_MAXICODE_MODE_4 • Printer.SYMBOL_MAXICODE_MODE_5 • Printer.SYMBOL_MAXICODE_MODE_6 • Printer.SYMBOL_GS1_DATABAR_STACKED • Printer.SYMBOL_GS1_DATABAR_STACKED_OMNIDIRECTIONAL • Printer.SYMBOL_GS1_DATABAR_EXPANDED_STACKED
	level	<ul style="list-style-type: none"> • Printer.LEVEL_0 • Printer.LEVEL_1 • Printer.LEVEL_2 • Printer.LEVEL_3 • Printer.LEVEL_4 • Printer.LEVEL_5 • Printer.LEVEL_6 • Printer.LEVEL_7 • Printer.LEVEL_8 • Printer.LEVEL_L • Printer.LEVEL_M • Printer.LEVEL_Q • Printer.LEVEL_H • Printer.PARAM_DEFAULT • Printer.PARAM_UNSPECIFIED
addCut	type	<ul style="list-style-type: none"> • Printer.CUT_FEED • Printer.CUT_NO_FEED • Printer.PARAM_DEFAULT
addSound	pattern	<ul style="list-style-type: none"> • Printer.PATTERN_NONE • Printer.PATTERN_A • Printer.PATTERN_B • Printer.PATTERN_C • Printer.PATTERN_D • Printer.PATTERN_E • Printer.PATTERN_ERROR • Printer.PATTERN_PAPER_EMPTY • Printer.PARAM_DEFAULT
	repeat	<ul style="list-style-type: none"> • 1 to 255 • Printer.PARAM_DEFAULT

TM-T82X**Printer Specifications**

Item	80mm Specification
Amount of initial feed	30 dots
Initial page mode area	576 x 831 dots
Maximum page mode area	576 x 1662 dots
Baseline of Font A	21 dots from the top of the character
Baseline of Font B	16 dots from the top of the character

Parameter Restrictions

API	Parameter	Specifiable Setting Value
Printer	printerSeries	<ul style="list-style-type: none"> Printer.TM_T82
	lang	<ul style="list-style-type: none"> Printer.MODEL_ANK Printer.MODEL_CHINESE Printer.MODEL_TAIWAN Printer.MODEL_SOUTHASIA
addTextLang	lang	<ul style="list-style-type: none"> Printer.LANG_EN (default) Printer.LANG_JA Printer.LANG_ZH_CN Printer.LANG_ZH_TW Printer.LANG_KO Printer.LANG_TH Printer.LANG_VI Printer.PARAM_DEFAULT
addTextFont	font	<ul style="list-style-type: none"> Printer.FONT_A (default) Printer.FONT_B Printer.PARAM_DEFAULT
addTextStyle	color	<ul style="list-style-type: none"> Printer.COLOR_1 (default) Printer.PARAM_UNSPECIFIED Printer.PARAM_DEFAULT
addImage	color	<ul style="list-style-type: none"> Printer.COLOR_1 Printer.PARAM_DEFAULT
	mode	<ul style="list-style-type: none"> Printer.MODE_MONO Printer.MODE_MONO_HIGH_DENSITY Printer.PARAM_DEFAULT
addBarcode	font	<ul style="list-style-type: none"> Printer.FONT_A (default) Printer.FONT_B Printer.PARAM_DEFAULT Printer.PARAM_UNSPECIFIED

API	Parameter	Specificable Setting Value
addSymbol	type	<ul style="list-style-type: none"> • Printer.SYMBOL_PDF417_STANDARD • Printer.SYMBOL_PDF417_TRUNCATED • Printer.SYMBOL_QRCODE_MODEL_1 • Printer.SYMBOL_QRCODE_MODEL_2 • Printer.SYMBOL_MAXICODE_MODE_2 • Printer.SYMBOL_MAXICODE_MODE_3 • Printer.SYMBOL_MAXICODE_MODE_4 • Printer.SYMBOL_MAXICODE_MODE_5 • Printer.SYMBOL_MAXICODE_MODE_6 • Printer.SYMBOL_GS1_DATABAR_STACKED • Printer.SYMBOL_GS1_DATABAR_STACKED_OMNIDIRECTIONAL • Printer.SYMBOL_GS1_DATABAR_EXPANDED_STACKED
	level	<ul style="list-style-type: none"> • Printer.LEVEL_0 • Printer.LEVEL_1 • Printer.LEVEL_2 • Printer.LEVEL_3 • Printer.LEVEL_4 • Printer.LEVEL_5 • Printer.LEVEL_6 • Printer.LEVEL_7 • Printer.LEVEL_8 • Printer.LEVEL_L • Printer.LEVEL_M • Printer.LEVEL_Q • Printer.LEVEL_H • Printer.PARAM_DEFAULT • Printer.PARAM_UNSPECIFIED
addCut	type	<ul style="list-style-type: none"> • Printer.CUT_FEED • Printer.CUT_NO_FEED • Printer.PARAM_DEFAULT
addSound	pattern	<ul style="list-style-type: none"> • Printer.PATTERN_NONE • Printer.PATTERN_A • Printer.PATTERN_B • Printer.PATTERN_C • Printer.PATTERN_D • Printer.PATTERN_E • Printer.PATTERN_ERROR • Printer.PATTERN_PAPER_EMPTY • Printer.PARAM_DEFAULT
	repeat	<ul style="list-style-type: none"> • 1 to 255 • Printer.PARAM_DEFAULT

TM-T83II**Printer Specifications**

Item		Specification
Amount of initial feed		30 dots
Initial page mode area		512 x 1662 dots
Maximum page mode area		512 x 1662 dots
Baseline of Font A		21 dots from the top of the character
Baseline of Font B	ANK	16 dots from the top of the character
	Chinese characters	15 dots from the top of the character

Parameter Restrictions

API	Parameter	Specificable Setting Value
Printer	printerSeries	<ul style="list-style-type: none"> Printer.TM_T83
	lang	<ul style="list-style-type: none"> Printer.MODEL_KOREAN
addTextLang	lang	<ul style="list-style-type: none"> Printer.LANG_EN (default) Printer.LANG_JA Printer.LANG_ZH_CN Printer.LANG_ZH_TW Printer.LANG_KO Printer.LANG_TH Printer.LANG_VI Printer.PARAM_DEFAULT
addTextFont	font	<ul style="list-style-type: none"> Printer.FONT_A (default) Printer.FONT_B Printer.PARAM_DEFAULT
addTextStyle	color	<ul style="list-style-type: none"> Printer.COLOR_1 (default) Printer.PARAM_UNSPECIFIED Printer.PARAM_DEFAULT
addImage	color	<ul style="list-style-type: none"> Printer.COLOR_1 Printer.PARAM_DEFAULT
	mode	<ul style="list-style-type: none"> Printer.MODE_MONO Printer.MODE_MONO_HIGH_DENSITY Printer.PARAM_DEFAULT
addBarcode	font	<ul style="list-style-type: none"> Printer.FONT_A (default) Printer.FONT_B Printer.PARAM_DEFAULT Printer.PARAM_UNSPECIFIED

API	Parameter	Specificable Setting Value
addSymbol	type	<ul style="list-style-type: none"> • Printer.SYMBOL_PDF417_STANDARD • Printer.SYMBOL_PDF417_TRUNCATED • Printer.SYMBOL_QRCODE_MODEL_1 • Printer.SYMBOL_QRCODE_MODEL_2 • Printer.SYMBOL_MAXICODE_MODE_2 • Printer.SYMBOL_MAXICODE_MODE_3 • Printer.SYMBOL_MAXICODE_MODE_4 • Printer.SYMBOL_MAXICODE_MODE_5 • Printer.SYMBOL_MAXICODE_MODE_6 • Printer.SYMBOL_GS1_DATABAR_STACKED • Printer.SYMBOL_GS1_DATABAR_STACKED_OMNIDIRECTIONAL • Printer.SYMBOL_GS1_DATABAR_EXPANDED_STACKED
	level	<ul style="list-style-type: none"> • Printer.LEVEL_0 • Printer.LEVEL_1 • Printer.LEVEL_2 • Printer.LEVEL_3 • Printer.LEVEL_4 • Printer.LEVEL_5 • Printer.LEVEL_6 • Printer.LEVEL_7 • Printer.LEVEL_8 • Printer.LEVEL_L • Printer.LEVEL_M • Printer.LEVEL_Q • Printer.LEVEL_H • Printer.PARAM_DEFAULT • Printer.PARAM_UNSPECIFIED
addCut	type	<ul style="list-style-type: none"> • Printer.CUT_FEED • Printer.CUT_NO_FEED • Printer.PARAM_DEFAULT
addSound	pattern	<ul style="list-style-type: none"> • Printer.PATTERN_NONE • Printer.PATTERN_A • Printer.PATTERN_B • Printer.PATTERN_C • Printer.PATTERN_D • Printer.PATTERN_E • Printer.PATTERN_ERROR • Printer.PATTERN_PAPER_EMPTY • Printer.PARAM_DEFAULT
	repeat	<ul style="list-style-type: none"> • 1 to 255 • Printer.PARAM_DEFAULT

TM-T83III**Printer Specifications**

Item		80mm Specification
Amount of initial feed		30 dots
Initial page mode area	for Korea	546 x 831 dots
	Other	576 x 831 dots
Maximum page mode area	for Korea	546 x 1662 dots
	Other	576 x 1662 dots
Baseline of Font A		21 dots from the top of the character
Baseline of Font B		16 dots from the top of the character

Parameter Restrictions

API	Parameter	Specificable Setting Value
Printer	printerSeries	<ul style="list-style-type: none"> Printer.TM_T83III
	lang	<ul style="list-style-type: none"> Printer.MODEL_ANK Printer.MODEL_CHINESE Printer.MODEL_KOREAN Printer.MODEL_SOUTHASIA
addTextLang	lang	<ul style="list-style-type: none"> Printer.LANG_EN (default) Printer.LANG_JA Printer.LANG_ZH_CN Printer.LANG_ZH_TW Printer.LANG_KO Printer.LANG_TH Printer.LANG_VI Printer.PARAM_DEFAULT
addTextFont	font	<ul style="list-style-type: none"> Printer.FONT_A (default) Printer.FONT_B Printer.PARAM_DEFAULT
addTextStyle	color	<ul style="list-style-type: none"> Printer.COLOR_1 (default) Printer.PARAM_UNSPECIFIED Printer.PARAM_DEFAULT
addImage	color	<ul style="list-style-type: none"> Printer.COLOR_1 Printer.PARAM_DEFAULT
	mode	<ul style="list-style-type: none"> Printer.MODE_MONO Printer.MODE_MONO_HIGH_DENSITY Printer.PARAM_DEFAULT

API	Parameter	Specifiable Setting Value
addBarcode	font	<ul style="list-style-type: none"> • Printer.FONT_A (default) • Printer.FONT_B • Printer.PARAM_DEFAULT • Printer.PARAM_UNSPECIFIED
addSymbol	type	<ul style="list-style-type: none"> • Printer.SYMBOL_PDF417_STANDARD • Printer.SYMBOL_PDF417_TRUNCATED • Printer.SYMBOL_QRCODE_MODEL_1 • Printer.SYMBOL_QRCODE_MODEL_2 • Printer.SYMBOL_MAXICODE_MODE_2 • Printer.SYMBOL_MAXICODE_MODE_3 • Printer.SYMBOL_MAXICODE_MODE_4 • Printer.SYMBOL_MAXICODE_MODE_5 • Printer.SYMBOL_MAXICODE_MODE_6 • Printer.SYMBOL_GS1_DATABAR_STACKED • Printer.SYMBOL_GS1_DATABAR_STACKED_OMNIDIRECTIONAL • Printer.SYMBOL_GS1_DATABAR_EXPANDED_STACKED
	level	<ul style="list-style-type: none"> • Printer.LEVEL_0 • Printer.LEVEL_1 • Printer.LEVEL_2 • Printer.LEVEL_3 • Printer.LEVEL_4 • Printer.LEVEL_5 • Printer.LEVEL_6 • Printer.LEVEL_7 • Printer.LEVEL_8 • Printer.LEVEL_L • Printer.LEVEL_M • Printer.LEVEL_Q • Printer.LEVEL_H • Printer.PARAM_DEFAULT • Printer.PARAM_UNSPECIFIED
addCut	type	<ul style="list-style-type: none"> • Printer.CUT_FEED • Printer.CUT_NO_FEED • Printer.PARAM_DEFAULT

API	Parameter	Specifiable Setting Value
addSound	pattern	<ul style="list-style-type: none"> • Printer.PATTERN_NONE • Printer.PATTERN_A • Printer.PATTERN_B • Printer.PATTERN_C • Printer.PATTERN_D • Printer.PATTERN_E • Printer.PATTERN_ERROR • Printer.PATTERN_PAPER_EMPTY • Printer.PARAM_DEFAULT
	repeat	<ul style="list-style-type: none"> • 1 to 255 • Printer.PARAM_DEFAULT

TM-T88V**Printer Specifications**

Item		58mm Specification	80mm Specification
Amount of initial feed		30 dots	
Initial page mode area		360 x 831 dots	512 x 831 dots
Maximum page mode area		360 x 1662 dots	512 x 1662 dots
Baseline of Font A		21 dots from the top of the character	
Baseline of Font B	ANK	16 dots from the top of the character	
	Chinese characters	15 dots from the top of the character	

Parameter Restrictions

API	Parameter	Specificable Setting Value
Printer	printerSeries	<ul style="list-style-type: none"> Printer.TM_T88
	lang	<ul style="list-style-type: none"> Printer.MODEL_ANK Printer.MODEL_CHINESE Printer.MODEL_TAIWAN Printer.MODEL_KOREAN Printer.MODEL_SOUTHASIA
addTextLang	lang	<ul style="list-style-type: none"> Printer.LANG_EN (default) Printer.LANG_JA Printer.LANG_ZH_CN Printer.LANG_ZH_TW Printer.LANG_KO Printer.LANG_TH Printer.LANG_VI Printer.PARAM_DEFAULT
addTextFont	font	<ul style="list-style-type: none"> Printer.FONT_A (default) Printer.FONT_B Printer.PARAM_DEFAULT
addTextStyle	color	<ul style="list-style-type: none"> Printer.COLOR_1 (default) Printer.PARAM_UNSPECIFIED Printer.PARAM_DEFAULT
addImage	color	<ul style="list-style-type: none"> Printer.COLOR_1 Printer.PARAM_DEFAULT
addBarcode	font	<ul style="list-style-type: none"> Printer.FONT_A (default) Printer.FONT_B Printer.PARAM_DEFAULT Printer.PARAM_UNSPECIFIED

API	Parameter	Specificable Setting Value
addSymbol	type	<ul style="list-style-type: none"> • Printer.SYMBOL_PDF417_STANDARD • Printer.SYMBOL_PDF417_TRUNCATED • Printer.SYMBOL_QRCODE_MODEL_1 • Printer.SYMBOL_QRCODE_MODEL_2 • Printer.SYMBOL_MAXICODE_MODE_2 • Printer.SYMBOL_MAXICODE_MODE_3 • Printer.SYMBOL_MAXICODE_MODE_4 • Printer.SYMBOL_MAXICODE_MODE_5 • Printer.SYMBOL_MAXICODE_MODE_6 • Printer.SYMBOL_GS1_DATABAR_STACKED • Printer.SYMBOL_GS1_DATABAR_STACKED_OMNIDIRECTIONAL • Printer.SYMBOL_GS1_DATABAR_EXPANDED_STACKED
	level	<ul style="list-style-type: none"> • Printer.LEVEL_0 • Printer.LEVEL_1 • Printer.LEVEL_2 • Printer.LEVEL_3 • Printer.LEVEL_4 • Printer.LEVEL_5 • Printer.LEVEL_6 • Printer.LEVEL_7 • Printer.LEVEL_8 • Printer.LEVEL_L • Printer.LEVEL_M • Printer.LEVEL_Q • Printer.LEVEL_H • Printer.PARAM_DEFAULT • Printer.PARAM_UNSPECIFIED
addCut	type	<ul style="list-style-type: none"> • Printer.CUT_FEED • Printer.CUT_NO_FEED • Printer.PARAM_DEFAULT
addSound	pattern	<ul style="list-style-type: none"> • Printer.PATTERN_NONE • Printer.PATTERN_A • Printer.PATTERN_B • Printer.PATTERN_C • Printer.PATTERN_D • Printer.PATTERN_E • Printer.PATTERN_ERROR • Printer.PATTERN_PAPER_EMPTY • Printer.PARAM_DEFAULT
	repeat	<ul style="list-style-type: none"> • 1 to 255 • Printer.PARAM_DEFAULT

TM-T88VI**Printer Specifications**

Item		58mm Specification	80mm Specification
Amount of initial feed		30 dots	
Initial page mode area		360 x 831 dots	512 x 831 dots
Maximum page mode area		360 x 1662 dots	512 x 1662 dots
Baseline of Font A		21 dots from the top of the character	
Baseline of Font B	ANK	16 dots from the top of the character	
	Chinese characters	15 dots from the top of the character	

Parameter Restrictions

API	Parameter	Specificable Setting Value
Printer	printerSeries	<ul style="list-style-type: none"> Printer.TM_T88
	lang	<ul style="list-style-type: none"> Printer.MODEL_ANK Printer.MODEL_CHINESE Printer.MODEL_TAIWAN Printer.MODEL_KOREAN Printer.MODEL_SOUTHASIA
addTextLang	lang	<ul style="list-style-type: none"> Printer.LANG_EN (default) Printer.LANG_JA Printer.LANG_ZH_CN Printer.LANG_ZH_TW Printer.LANG_KO Printer.LANG_TH Printer.LANG_VI Printer.PARAM_DEFAULT
addTextFont	font	<ul style="list-style-type: none"> Printer.FONT_A (default) Printer.FONT_B Printer.PARAM_DEFAULT
addTextStyle	color	<ul style="list-style-type: none"> Printer.COLOR_1 (default) Printer.PARAM_UNSPECIFIED Printer.PARAM_DEFAULT
addImage	color	<ul style="list-style-type: none"> Printer.COLOR_1 Printer.PARAM_DEFAULT
addBarcode	font	<ul style="list-style-type: none"> Printer.FONT_A (default) Printer.FONT_B Printer.PARAM_DEFAULT Printer.PARAM_UNSPECIFIED

API	Parameter	Specificable Setting Value
addSymbol	type	<ul style="list-style-type: none"> • Printer.SYMBOL_PDF417_STANDARD • Printer.SYMBOL_PDF417_TRUNCATED • Printer.SYMBOL_QRCODE_MODEL_1 • Printer.SYMBOL_QRCODE_MODEL_2 • Printer.SYMBOL_MAXICODE_MODE_2 • Printer.SYMBOL_MAXICODE_MODE_3 • Printer.SYMBOL_MAXICODE_MODE_4 • Printer.SYMBOL_MAXICODE_MODE_5 • Printer.SYMBOL_MAXICODE_MODE_6 • Printer.SYMBOL_GS1_DATABAR_STACKED • Printer.SYMBOL_GS1_DATABAR_STACKED_OMNIDIRECTIONAL • Printer.SYMBOL_GS1_DATABAR_EXPANDED_STACKED • Printer.SYMBOL_AZTECCODE_FULLRANGE • Printer.SYMBOL_AZTECCODE_COMPACT • Printer.SYMBOL_DATAMATRIX_SQUARE • Printer.SYMBOL_DATAMATRIX_RECTANGLE_8 • Printer.SYMBOL_DATAMATRIX_RECTANGLE_12 • Printer.SYMBOL_DATAMATRIX_RECTANGLE_16
addPageLine	lineStyle	<ul style="list-style-type: none"> • Printer.LINE_THIN • Printer.LINE_MEDIUM • Printer.LINE_THICK • Printer.PARAM_DEFAULT
addPageRectangle	lineStyle	<ul style="list-style-type: none"> • Printer.LINE_THIN • Printer.LINE_MEDIUM • Printer.LINE_THICK • Printer.PARAM_DEFAULT
addCut	type	<ul style="list-style-type: none"> • Printer.CUT_FEED • Printer.CUT_NO_FEED • Printer.PARAM_DEFAULT
addSound	pattern	<ul style="list-style-type: none"> • Printer.PATTERN_NONE • Printer.PATTERN_A • Printer.PATTERN_B • Printer.PATTERN_C • Printer.PATTERN_D • Printer.PATTERN_E • Printer.PATTERN_ERROR • Printer.PATTERN_PAPER_EMPTY • Printer.PARAM_DEFAULT
	repeat	<ul style="list-style-type: none"> • 1 to 255 • Printer.PARAM_DEFAULT

API	Parameter	Specifiable Setting Value
setPrinterSetting	value	<ul style="list-style-type: none"> • Printer.Setting.PaperWidth58_0 • Printer.Setting.PaperWidth80_0 • Printer.Setting.PrintDensityDIP • Printer.Setting.PrintDensity70 • Printer.Setting.PrintDensity75 • Printer.Setting.PrintDensity80 • Printer.Setting.PrintDensity85 • Printer.Setting.PrintDensity90 • Printer.Setting.PrintDensity95 • Printer.Setting.PrintDensity100 • Printer.Setting.PrintDensity105 • Printer.Setting.PrintDensity110 • Printer.Setting.PrintDensity115 • Printer.Setting.PrintDensity120 • Printer.Setting.PrintDensity125 • Printer.Setting.PrintDensity130 • Printer.Setting.PrintSpeed1 • Printer.Setting.PrintSpeed2 • Printer.Setting.PrintSpeed3 • Printer.Setting.PrintSpeed4 • Printer.Setting.PrintSpeed5 • Printer.Setting.PrintSpeed6 • Printer.Setting.PrintSpeed7 • Printer.Setting.PrintSpeed8 • Printer.Setting.PrintSpeed9 • Printer.Setting.PrintSpeed10 • Printer.Setting.PrintSpeed11 • Printer.Setting.PrintSpeed12 • Printer.Setting.PrintSpeed13 • Printer.Setting.PrintSpeed14
downloadFirmwareList	printerModel	<ul style="list-style-type: none"> • TM-T88VI
LineDisplay	displaySeries	<ul style="list-style-type: none"> • LineDisplay.DM_D110 • LineDisplay.DM_D30

TM-T100**Printer Specifications**

Item	80mm Specification
Amount of initial feed	30 dots
Initial page mode area	576 x 831 dots
Maximum page mode area	576 x 1662 dots
Baseline of Font A	21 dots from the top of the character
Baseline of Font B	16 dots from the top of the character

Parameter Restrictions

API	Parameter	Specifiable Setting Value
Printer	printerSeries	<ul style="list-style-type: none"> Printer.TM_T100
	lang	<ul style="list-style-type: none"> Printer.MODEL_ANK Printer.MODEL_CHINESE
addTextLang	lang	<ul style="list-style-type: none"> Printer.LANG_EN (default) Printer.LANG_JA Printer.LANG_ZH_CN Printer.LANG_ZH_TW Printer.LANG_KO Printer.LANG_TH Printer.LANG_VI Printer.PARAM_DEFAULT
addTextFont	font	<ul style="list-style-type: none"> Printer.FONT_A (default) Printer.FONT_B Printer.PARAM_DEFAULT
addTextStyle	color	<ul style="list-style-type: none"> Printer.COLOR_1 (default) Printer.PARAM_UNSPECIFIED Printer.PARAM_DEFAULT
addImage	color	<ul style="list-style-type: none"> Printer.COLOR_1 Printer.PARAM_DEFAULT
	mode	<ul style="list-style-type: none"> Printer.MODE_MONO Printer.MODE_MONO_HIGH_DENSITY Printer.PARAM_DEFAULT
addBarcode	font	<ul style="list-style-type: none"> Printer.FONT_A (default) Printer.FONT_B Printer.PARAM_DEFAULT Printer.PARAM_UNSPECIFIED

API	Parameter	Specifiable Setting Value
addSymbol	type	<ul style="list-style-type: none"> • Printer.SYMBOL_PDF417_STANDARD • Printer.SYMBOL_PDF417_TRUNCATED • Printer.SYMBOL_QRCODE_MODEL_1 • Printer.SYMBOL_QRCODE_MODEL_2 • Printer.SYMBOL_MAXICODE_MODE_2 • Printer.SYMBOL_MAXICODE_MODE_3 • Printer.SYMBOL_MAXICODE_MODE_4 • Printer.SYMBOL_MAXICODE_MODE_5 • Printer.SYMBOL_MAXICODE_MODE_6 • Printer.SYMBOL_GS1_DATABAR_STACKED • Printer.SYMBOL_GS1_DATABAR_STACKED_OMNIDIRECTIONAL • Printer.SYMBOL_GS1_DATABAR_EXPANDED_STACKED
	level	<ul style="list-style-type: none"> • Printer.LEVEL_0 • Printer.LEVEL_1 • Printer.LEVEL_2 • Printer.LEVEL_3 • Printer.LEVEL_4 • Printer.LEVEL_5 • Printer.LEVEL_6 • Printer.LEVEL_7 • Printer.LEVEL_8 • Printer.LEVEL_L • Printer.LEVEL_M • Printer.LEVEL_Q • Printer.LEVEL_H • Printer.PARAM_DEFAULT • Printer.PARAM_UNSPECIFIED
addCut	type	<ul style="list-style-type: none"> • Printer.CUT_FEED • Printer.CUT_NO_FEED • Printer.PARAM_DEFAULT
addSound	pattern	<ul style="list-style-type: none"> • Printer.PATTERN_NONE • Printer.PATTERN_A • Printer.PATTERN_B • Printer.PATTERN_C • Printer.PATTERN_D • Printer.PATTERN_E • Printer.PATTERN_ERROR • Printer.PATTERN_PAPER_EMPTY • Printer.PARAM_DEFAULT
	repeat	<ul style="list-style-type: none"> • 1 to 255 • Printer.PARAM_DEFAULT

TM-U220**Printer Specifications**

Item	76mm Specification	69.5mm Specification	57.5mm Specification
Amount of initial feed	12 dots		

Parameter Restrictions

API	Parameter	Specificable Setting Value
Printer	printerSeries	<ul style="list-style-type: none"> Printer.TM_U220
	lang	<ul style="list-style-type: none"> Printer.MODEL_ANK Printer.MODEL_CHINESE Printer.MODEL_TAIWAN Printer.MODEL_KOREAN Printer.MODEL_THAI
addTextLang	lang	<ul style="list-style-type: none"> Printer.LANG_EN (default) Printer.LANG_JA Printer.LANG_ZH_CN Printer.LANG_ZH_TW Printer.LANG_KO Printer.LANG_TH Printer.LANG_VI Printer.PARAM_DEFAULT
addTextFont	font	<ul style="list-style-type: none"> Printer.FONT_A (default) Printer.FONT_B Printer.PARAM_DEFAULT
addTextStyle	color	<ul style="list-style-type: none"> Printer.COLOR_1 (default) Printer.COLOR_2 Printer.PARAM_UNSPECIFIED Printer.PARAM_DEFAULT
addImage	color	<ul style="list-style-type: none"> Printer.COLOR_1 Printer.COLOR_2 Printer.PARAM_DEFAULT
	mode	<ul style="list-style-type: none"> Printer.MODE_MONO Printer.MODE_MONO_HIGH_DENSITY Printer.PARAM_DEFAULT
addLogo	key2	<ul style="list-style-type: none"> Printer.PARAM_DEFAULT
addCut	type	<ul style="list-style-type: none"> Printer.CUT_FEED Printer.CUT_NO_FEED Printer.PARAM_DEFAULT

TM-U330**Printer Specifications**

Item	76mm Specification	69.5mm Specification	57.5mm Specification
Amount of initial feed	12 dots		

Parameter Restrictions

API	Parameter	Specificable Setting Value
Printer	printerSeries	<ul style="list-style-type: none"> Printer.TM_U330
	lang	<ul style="list-style-type: none"> Printer.MODEL_CHINESE
addTextLang	lang	<ul style="list-style-type: none"> Printer.LANG_EN (default) Printer.LANG_JA Printer.LANG_ZH_CN Printer.LANG_ZH_TW Printer.LANG_KO Printer.LANG_TH Printer.LANG_VI Printer.PARAM_DEFAULT
addTextFont	font	<ul style="list-style-type: none"> Printer.FONT_A (default) Printer.FONT_B Printer.PARAM_DEFAULT
addTextStyle	color	<ul style="list-style-type: none"> Printer.COLOR_1 (default) Printer.COLOR_2 Printer.PARAM_UNSPECIFIED Printer.PARAM_DEFAULT
addImage	color	<ul style="list-style-type: none"> Printer.COLOR_1 Printer.COLOR_2 Printer.PARAM_DEFAULT
	mode	<ul style="list-style-type: none"> Printer.MODE_MONO Printer.MODE_MONO_HIGH_DENSITY Printer.PARAM_DEFAULT
addLogo	key2	<ul style="list-style-type: none"> Printer.PARAM_DEFAULT
addBarcode	type	<ul style="list-style-type: none"> Printer.BARCODE_CODE39 Printer.BARCODE_CODE128
	font	<ul style="list-style-type: none"> Printer.FONT_A (default) Printer.FONT_B Printer.PARAM_DEFAULT Printer.PARAM_UNSPECIFIED

API	Parameter	Specificable Setting Value
addSymbol	type	<ul style="list-style-type: none"> • Printer.SYMBOL_QRCODE_MODEL_1 • Printer.SYMBOL_QRCODE_MODEL_2
	level	<ul style="list-style-type: none"> • Printer.LEVEL_L • Printer.LEVEL_M • Printer.LEVEL_Q • Printer.LEVEL_H • Printer.PARAM_DEFAULT • Printer.PARAM_UNSPECIFIED
addCut	type	<ul style="list-style-type: none"> • Printer.CUT_FEED • Printer.CUT_NO_FEED • Printer.PARAM_DEFAULT
addFeedPosition	position	<ul style="list-style-type: none"> • Printer.FEED_CUTTING

TM-P20**Printer Specifications**

Item	Specification
Amount of initial feed	30 dots
Initial page mode area	384 x 2400 dots
Maximum page mode area	384 x 2400 dots
Baseline of Font A	21 dots from the top of the character
Baseline of Font B	21 dots from the top of the character
Baseline of Font C	16 dots from the top of the character
Baseline of Font D	21 dots from the top of the character
Baseline of Font E	15 dots from the top of the character

Parameter Restrictions

API	Parameter	Specificable Setting Value
Printer	printerSeries	<ul style="list-style-type: none"> Printer.TM_P20
	lang	<ul style="list-style-type: none"> Printer.MODEL_ANK Printer.MODEL_CHINESE Printer.MODEL_TAIWAN Printer.MODEL_SOUTHASIA
addTextLang	lang	<ul style="list-style-type: none"> Printer.LANG_EN (default) Printer.LANG_JA Printer.LANG_ZH_CN Printer.LANG_ZH_TW Printer.LANG_KO Printer.LANG_TH Printer.LANG_VI Printer.PARAM_DEFAULT
addTextStyle	color	<ul style="list-style-type: none"> Printer.COLOR_1 (default) Printer.PARAM_UNSPECIFIED Printer.PARAM_DEFAULT
addImage	color	<ul style="list-style-type: none"> Printer.COLOR_1 Printer.PARAM_DEFAULT
	mode	<ul style="list-style-type: none"> Printer.MODE_MONO Printer.MODE_MONO_HIGH_DENSITY Printer.PARAM_DEFAULT

API	Parameter	Specifiable Setting Value
addSymbol	type	<ul style="list-style-type: none"> • Printer.SYMBOL_PDF417_STANDARD • Printer.SYMBOL_PDF417_TRUNCATED • Printer.SYMBOL_QRCODE_MODEL_1 • Printer.SYMBOL_QRCODE_MODEL_2 • Printer.SYMBOL_MAXICODE_MODE_2 • Printer.SYMBOL_MAXICODE_MODE_3 • Printer.SYMBOL_MAXICODE_MODE_4 • Printer.SYMBOL_MAXICODE_MODE_5 • Printer.SYMBOL_MAXICODE_MODE_6 • Printer.SYMBOL_GS1_DATABAR_STACKED • Printer.SYMBOL_GS1_DATABAR_STACKED_OMNIDIRECTIONAL • Printer.SYMBOL_GS1_DATABAR_EXPANDED_STACKED • Printer.SYMBOL_AZTECCODE_FULLRANGE • Printer.SYMBOL_AZTECCODE_COMPACT • Printer.SYMBOL_DATAMATRIX_SQUARE • Printer.SYMBOL_DATAMATRIX_RECTANGLE_8 • Printer.SYMBOL_DATAMATRIX_RECTANGLE_12 • Printer.SYMBOL_DATAMATRIX_RECTANGLE_16
addPageLine	lineStyle	<ul style="list-style-type: none"> • Printer.LINE_THIN • Printer.LINE_MEDIUM • Printer.LINE_THICK • Printer.PARAM_DEFAULT
addPageRectangle	lineStyle	<ul style="list-style-type: none"> • Printer.LINE_THIN • Printer.LINE_MEDIUM • Printer.LINE_THICK • Printer.PARAM_DEFAULT
addCut	type	<ul style="list-style-type: none"> • Printer.CUT_FEED • Printer.CUT_NO_FEED • Printer.PARAM_DEFAULT

API	Parameter	Specifiable Setting Value
addSound	pattern	<ul style="list-style-type: none"> • Printer.PATTERN_NONE • Printer.PATTERN_1 • Printer.PATTERN_2 • Printer.PATTERN_3 • Printer.PATTERN_4 • Printer.PATTERN_5 • Printer.PATTERN_6 • Printer.PATTERN_7 • Printer.PATTERN_8 • Printer.PATTERN_9 • Printer.PATTERN_10 • Printer.PARAM_DEFAULT
	repeat	<ul style="list-style-type: none"> • 1 to 255 • Printer.PARAM_DEFAULT
addFeedPosition	position	<ul style="list-style-type: none"> • Printer.FEED_CUTTING • Printer.FEED_CURRENT_TOF • Printer.FEED_NEXT_TOF
addLayout	type	<ul style="list-style-type: none"> • Printer.LAYOUT_RECEIPT • Printer.LAYOUT_RECEIPT_BM
	height	<ul style="list-style-type: none"> • Receipt (without black mark) • Receipt (with black mark)
	marginTop	<ul style="list-style-type: none"> • Receipt (without black mark) • Receipt (with black mark)
	marginBottom	<ul style="list-style-type: none"> • Receipt (without black mark) • Receipt (with black mark)
	offsetCut	<ul style="list-style-type: none"> • Receipt (without black mark) • Receipt (with black mark)
	offsetLabel	<ul style="list-style-type: none"> • Receipt (without black mark) • Receipt (with black mark)
getMaintenanceCounter	type	<ul style="list-style-type: none"> • Printer.MaintenanceCounter.PaperFeed
resetMaintenanceCounter	type	<ul style="list-style-type: none"> • Printer.MaintenanceCounter.PaperFeed
getPrinterSetting	type	<ul style="list-style-type: none"> • Printer.Setting.PrintDensity • Printer.Setting.PrintSpeed

API	Parameter	Specifiable Setting Value
setPrinterSetting	type	<ul style="list-style-type: none"> • Printer.Setting.PrintDensity • Printer.Setting.PrintSpeed
	value	<ul style="list-style-type: none"> • Printer.Setting.PrintDensity70 • Printer.Setting.PrintDensity75 • Printer.Setting.PrintDensity80 • Printer.Setting.PrintDensity85 • Printer.Setting.PrintDensity90 • Printer.Setting.PrintDensity95 • Printer.Setting.PrintDensity100 • Printer.Setting.PrintDensity105 • Printer.Setting.PrintDensity110 • Printer.Setting.PrintDensity115 • Printer.Setting.PrintDensity120 • Printer.Setting.PrintDensity125 • Printer.Setting.PrintDensity130 • Printer.Setting.PrintSpeed1 • Printer.Setting.PrintSpeed2 • Printer.Setting.PrintSpeed3 • Printer.Setting.PrintSpeed4 • Printer.Setting.PrintSpeed5 • Printer.Setting.PrintSpeed6 • Printer.Setting.PrintSpeed7 • Printer.Setting.PrintSpeed8 • Printer.Setting.PrintSpeed9 • Printer.Setting.PrintSpeed10

TM-P60 (Receipt)

Printer Specifications

Item	58mm Specification	60mm Specification
Amount of initial feed	30 dots	
Initial page mode area	420 x 1200 dots	432 x 1200 dots
Maximum page mode area	420 x 1200 dots	432 x 1200 dots
Baseline of Font A	21 dots from the top of the character	
Baseline of Font B	21 dots from the top of the character	
Baseline of Font C	15 dots from the top of the character	

Parameter Restrictions

API	Parameter	Specificable Setting Value
Printer	printerSeries	<ul style="list-style-type: none"> Printer.TM_P60
	lang	<ul style="list-style-type: none"> Printer.MODEL_ANK Printer.MODEL_TAIWAN
addTextLang	lang	<ul style="list-style-type: none"> Printer.LANG_EN (default) Printer.LANG_JA Printer.LANG_ZH_CN Printer.LANG_ZH_TW Printer.LANG_KO Printer.LANG_TH Printer.LANG_VI Printer.PARAM_DEFAULT
addTextFont	font	<ul style="list-style-type: none"> Printer.FONT_A (default) Printer.FONT_B Printer.FONT_C Printer.PARAM_DEFAULT
addTextStyle	color	<ul style="list-style-type: none"> Printer.COLOR_1 (default) Printer.PARAM_UNSPECIFIED Printer.PARAM_DEFAULT
addImage	color	<ul style="list-style-type: none"> Printer.COLOR_1 Printer.PARAM_DEFAULT
	mode	<ul style="list-style-type: none"> Printer.MODE_MONO Printer.MODE_MONO_HIGH_DENSITY Printer.PARAM_DEFAULT

API	Parameter	Specifiable Setting Value
addBarcode	type	<ul style="list-style-type: none"> • Printer.BARCODE_UPC_A • Printer.BARCODE_UPC_E • Printer.BARCODE_EAN13 • Printer.BARCODE_JAN13 • Printer.BARCODE_EAN8 • Printer.BARCODE_JAN8 • Printer.BARCODE_CODE39 • Printer.BARCODE_ITF • Printer.BARCODE_CODABAR • Printer.BARCODE_CODE93 • Printer.BARCODE_CODE128
	font	<ul style="list-style-type: none"> • Printer.FONT_A (default) • Printer.FONT_B • Printer.FONT_C • Printer.PARAM_DEFAULT • Printer.PARAM_UNSPECIFIED
addPageLine	lineStyle	<ul style="list-style-type: none"> • Printer.LINE_THIN • Printer.LINE_MEDIUM • Printer.LINE_THICK • Printer.PARAM_DEFAULT
addPageRectangle	lineStyle	<ul style="list-style-type: none"> • Printer.LINE_THIN • Printer.LINE_MEDIUM • Printer.LINE_THICK • Printer.PARAM_DEFAULT
addCut	type	<ul style="list-style-type: none"> • Printer.CUT_FEED • Printer.CUT_NO_FEED • Printer.PARAM_DEFAULT

TM-P60 (Peeler)

Printer Specifications

Item	58mm Specification	60mm Specification
Amount of initial feed	30 dots	
Initial page mode area	420 x 1200 dots	432 x 1200 dots
Maximum page mode area	420 x 1200 dots	432 x 1200 dots
Baseline of Font A	21 dots from the top of the character	
Baseline of Font B	21 dots from the top of the character	
Baseline of Font C	15 dots from the top of the character	

Parameter Restrictions

API	Parameter	Specificable Setting Value
Printer	printerSeries	<ul style="list-style-type: none"> Printer.TM_P60
	lang	<ul style="list-style-type: none"> Printer.MODEL_ANK
addTextLang	lang	<ul style="list-style-type: none"> Printer.LANG_EN (default) Printer.LANG_JA Printer.LANG_ZH_CN Printer.LANG_ZH_TW Printer.LANG_KO Printer.LANG_TH Printer.LANG_VI Printer.PARAM_DEFAULT
addTextFont	font	<ul style="list-style-type: none"> Printer.FONT_A (default) Printer.FONT_B Printer.FONT_C Printer.PARAM_DEFAULT
addTextStyle	color	<ul style="list-style-type: none"> Printer.COLOR_1 (default) Printer.PARAM_UNSPECIFIED Printer.PARAM_DEFAULT
addImage	color	<ul style="list-style-type: none"> Printer.COLOR_1 Printer.PARAM_DEFAULT
	mode	<ul style="list-style-type: none"> Printer.MODE_MONO Printer.MODE_MONO_HIGH_DENSITY Printer.PARAM_DEFAULT

API	Parameter	Specifiable Setting Value
addBarcode	type	<ul style="list-style-type: none"> • Printer.BARCODE_UPC_A • Printer.BARCODE_UPC_E • Printer.BARCODE_EAN13 • Printer.BARCODE_JAN13 • Printer.BARCODE_EAN8 • Printer.BARCODE_JAN8 • Printer.BARCODE_CODE39 • Printer.BARCODE_ITF • Printer.BARCODE_CODABAR • Printer.BARCODE_CODE93 • Printer.BARCODE_CODE128
	font	<ul style="list-style-type: none"> • Printer.FONT_A (default) • Printer.FONT_B • Printer.FONT_C • Printer.PARAM_DEFAULT • Printer.PARAM_UNSPECIFIED
addSymbol	type	<ul style="list-style-type: none"> • Printer.SYMBOL_PDF417_STANDARD • Printer.SYMBOL_PDF417_TRUNCATED • Printer.SYMBOL_QRCODE_MODEL_1 • Printer.SYMBOL_QRCODE_MODEL_2 • Printer.SYMBOL_MAXICODE_MODE_2 • Printer.SYMBOL_MAXICODE_MODE_3 • Printer.SYMBOL_MAXICODE_MODE_4 • Printer.SYMBOL_MAXICODE_MODE_5 • Printer.SYMBOL_MAXICODE_MODE_6 • Printer.SYMBOL_GS1_DATABAR_STACKED • Printer.SYMBOL_GS1_DATABAR_STACKED_OMNIDIRECTIONAL • Printer.SYMBOL_GS1_DATABAR_EXPANDED_STACKED • Printer.SYMBOL_AZTECCODE_FULLRANGE • Printer.SYMBOL_AZTECCODE_COMPACT • Printer.SYMBOL_DATAMATRIX_SQUARE • Printer.SYMBOL_DATAMATRIX_RECTANGLE_8 • Printer.SYMBOL_DATAMATRIX_RECTANGLE_12 • Printer.SYMBOL_DATAMATRIX_RECTANGLE_16
addPageLine	lineStyle	<ul style="list-style-type: none"> • Printer.LINE_THIN • Printer.LINE_MEDIUM • Printer.LINE_THICK • Printer.PARAM_DEFAULT
addPageRectangle	lineStyle	<ul style="list-style-type: none"> • Printer.LINE_THIN • Printer.LINE_MEDIUM • Printer.LINE_THICK • Printer.PARAM_DEFAULT

API	Parameter	Specifiable Setting Value
addCut	type	<ul style="list-style-type: none">• Printer.CUT_FEED• Printer.CUT_NO_FEED• Printer.PARAM_DEFAULT

TM-P60II (Receipt)

Printer Specifications

Item	Receipt Specification	Die-cut Label Specification
Amount of initial feed	30 dots	
Initial page mode area	432 x 1624 dots	400 x 1624 dots
Maximum page mode area	432 x 1624 dots	400 x 1624 dots
Baseline of Font A	21 dots from the top of the character	
Baseline of Font B	16 dots from the top of the character	
Baseline of Font C	15 dots from the top of the character	

Parameter Restrictions

API	Parameter	Specificable Setting Value
Printer	printerSeries	<ul style="list-style-type: none"> Printer.TM_P60II
	lang	<ul style="list-style-type: none"> Printer.MODEL_ANK Printer.MODEL_TAIWAN
addTextLang	lang	<ul style="list-style-type: none"> Printer.LANG_EN (default) Printer.LANG_JA Printer.LANG_ZH_CN Printer.LANG_ZH_TW Printer.LANG_KO Printer.LANG_TH Printer.LANG_VI Printer.PARAM_DEFAULT
addTextFont	font	<ul style="list-style-type: none"> Printer.FONT_A (default) Printer.FONT_B Printer.FONT_C Printer.PARAM_DEFAULT
addTextStyle	color	<ul style="list-style-type: none"> Printer.COLOR_1 (default) Printer.PARAM_UNSPECIFIED Printer.PARAM_DEFAULT
addImage	color	<ul style="list-style-type: none"> Printer.COLOR_1 Printer.PARAM_DEFAULT
	mode	<ul style="list-style-type: none"> Printer.MODE_MONO Printer.MODE_MONO_HIGH_DENSITY Printer.PARAM_DEFAULT

API	Parameter	Specificable Setting Value
addBarcode	font	<ul style="list-style-type: none"> • Printer.FONT_A (default) • Printer.FONT_B • Printer.FONT_C • Printer.PARAM_DEFAULT • Printer.PARAM_UNSPECIFIED
addSymbol	type	<ul style="list-style-type: none"> • Printer.SYMBOL_PDF417_STANDARD • Printer.SYMBOL_PDF417_TRUNCATED • Printer.SYMBOL_QRCODE_MODEL_1 • Printer.SYMBOL_QRCODE_MODEL_2 • Printer.SYMBOL_MAXICODE_MODE_2 • Printer.SYMBOL_MAXICODE_MODE_3 • Printer.SYMBOL_MAXICODE_MODE_4 • Printer.SYMBOL_MAXICODE_MODE_5 • Printer.SYMBOL_MAXICODE_MODE_6 • Printer.SYMBOL_GS1_DATABAR_STACKED • Printer.SYMBOL_GS1_DATABAR_STACKED_OMNIDIRECTIONAL • Printer.SYMBOL_GS1_DATABAR_EXPANDED_STACKED • Printer.SYMBOL_AZTECCODE_FULLRANGE • Printer.SYMBOL_AZTECCODE_COMPACT • Printer.SYMBOL_DATAMATRIX_SQUARE • Printer.SYMBOL_DATAMATRIX_RECTANGLE_8 • Printer.SYMBOL_DATAMATRIX_RECTANGLE_12 • Printer.SYMBOL_DATAMATRIX_RECTANGLE_16
addPageLine	lineStyle	<ul style="list-style-type: none"> • Printer.LINE_THIN • Printer.LINE_MEDIUM • Printer.LINE_THICK • Printer.PARAM_DEFAULT
addPageRectangle	lineStyle	<ul style="list-style-type: none"> • Printer.LINE_THIN • Printer.LINE_MEDIUM • Printer.LINE_THICK • Printer.PARAM_DEFAULT
addCut	type	<ul style="list-style-type: none"> • Printer.CUT_FEED • Printer.CUT_NO_FEED • Printer.PARAM_DEFAULT

API	Parameter	Specifiable Setting Value
addSound	pattern	<ul style="list-style-type: none"> • Printer.PATTERN_NONE • Printer.PATTERN_1 • Printer.PATTERN_2 • Printer.PATTERN_3 • Printer.PATTERN_4 • Printer.PATTERN_5 • Printer.PATTERN_6 • Printer.PATTERN_7 • Printer.PATTERN_8 • Printer.PATTERN_9 • Printer.PATTERN_10 • Printer.PARAM_DEFAULT
	repeat	<ul style="list-style-type: none"> • 1 to 255 • Printer.PARAM_DEFAULT

TM-P60II (Peeler)

Printer Specifications

Item	Receipt Specification	Die-cut Label Specification
Amount of initial feed	30 dots	
Initial page mode area	432 x 1624 dots	400 x 1624 dots
Maximum page mode area	432 x 1624 dots	400 x 1624 dots
Baseline of Font A	21 dots from the top of the character	
Baseline of Font B	16 dots from the top of the character	
Baseline of Font C	15 dots from the top of the character	

Parameter Restrictions

API	Parameter	Specificable Setting Value
Printer	printerSeries	<ul style="list-style-type: none"> Printer.TM_P60II
	lang	<ul style="list-style-type: none"> Printer.MODEL_ANK Printer.MODEL_TAIWAN
addTextLang	lang	<ul style="list-style-type: none"> Printer.LANG_EN (default) Printer.LANG_JA Printer.LANG_ZH_CN Printer.LANG_ZH_TW Printer.LANG_KO Printer.LANG_TH Printer.LANG_VI Printer.PARAM_DEFAULT
addTextFont	font	<ul style="list-style-type: none"> Printer.FONT_A (default) Printer.FONT_B Printer.FONT_C Printer.PARAM_DEFAULT
addTextStyle	color	<ul style="list-style-type: none"> Printer.COLOR_1 (default) Printer.PARAM_UNSPECIFIED Printer.PARAM_DEFAULT
addImage	color	<ul style="list-style-type: none"> Printer.COLOR_1 Printer.PARAM_DEFAULT
	mode	<ul style="list-style-type: none"> Printer.MODE_MONO Printer.MODE_MONO_HIGH_DENSITY Printer.PARAM_DEFAULT

API	Parameter	Specifiable Setting Value
addBarcode	font	<ul style="list-style-type: none"> • Printer.FONT_A (default) • Printer.FONT_B • Printer.FONT_C • Printer.PARAM_DEFAULT • Printer.PARAM_UNSPECIFIED
addSymbol	type	<ul style="list-style-type: none"> • Printer.SYMBOL_PDF417_STANDARD • Printer.SYMBOL_PDF417_TRUNCATED • Printer.SYMBOL_QRCODE_MODEL_1 • Printer.SYMBOL_QRCODE_MODEL_2 • Printer.SYMBOL_MAXICODE_MODE_2 • Printer.SYMBOL_MAXICODE_MODE_3 • Printer.SYMBOL_MAXICODE_MODE_4 • Printer.SYMBOL_MAXICODE_MODE_5 • Printer.SYMBOL_MAXICODE_MODE_6 • Printer.SYMBOL_GS1_DATABAR_STACKED • Printer.SYMBOL_GS1_DATABAR_STACKED_OMNIDIRECTIONAL • Printer.SYMBOL_GS1_DATABAR_EXPANDED_STACKED • Printer.SYMBOL_AZTECCODE_FULLRANGE • Printer.SYMBOL_AZTECCODE_COMPACT • Printer.SYMBOL_DATAMATRIX_SQUARE • Printer.SYMBOL_DATAMATRIX_RECTANGLE_8 • Printer.SYMBOL_DATAMATRIX_RECTANGLE_12 • Printer.SYMBOL_DATAMATRIX_RECTANGLE_16
addPageLine	lineStyle	<ul style="list-style-type: none"> • Printer.LINE_THIN • Printer.LINE_MEDIUM • Printer.LINE_THICK • Printer.PARAM_DEFAULT
addPageRectangle	lineStyle	<ul style="list-style-type: none"> • Printer.LINE_THIN • Printer.LINE_MEDIUM • Printer.LINE_THICK • Printer.PARAM_DEFAULT
addCut	type	<ul style="list-style-type: none"> • Printer.CUT_FEED • Printer.CUT_NO_FEED • Printer.PARAM_DEFAULT

API	Parameter	Specifiable Setting Value
addSound	pattern	<ul style="list-style-type: none"> • Printer.PATTERN_NONE • Printer.PATTERN_1 • Printer.PATTERN_2 • Printer.PATTERN_3 • Printer.PATTERN_4 • Printer.PATTERN_5 • Printer.PATTERN_6 • Printer.PATTERN_7 • Printer.PATTERN_8 • Printer.PATTERN_9 • Printer.PATTERN_10 • Printer.PARAM_DEFAULT
	repeat	<ul style="list-style-type: none"> • 1 to 255 • Printer.PARAM_DEFAULT

TM-P80**Printer Specifications**

Item	Specification
Amount of initial feed	30 dots
Initial page mode area	576 x 1662 dots
Maximum page mode area	576 x 1662 dots
Baseline of Font A	21 dots from the top of the character
Baseline of Font B	21 dots from the top of the character
Baseline of Font C	15 dots from the top of the character

Parameter Restrictions

API	Parameter	Specificable Setting Value
Printer	printerSeries	<ul style="list-style-type: none"> Printer.TM_P80
	lang	<ul style="list-style-type: none"> Printer.MODEL_ANK Printer.MODEL_TAIWAN
addTextLang	lang	<ul style="list-style-type: none"> Printer.LANG_EN (default) Printer.LANG_JA Printer.LANG_ZH_CN Printer.LANG_ZH_TW Printer.LANG_KO Printer.LANG_TH Printer.LANG_VI Printer.PARAM_DEFAULT
addTextFont	font	<ul style="list-style-type: none"> Printer.FONT_A (default) Printer.FONT_B Printer.PARAM_DEFAULT
addTextStyle	color	<ul style="list-style-type: none"> Printer.COLOR_1 (default) Printer.PARAM_UNSPECIFIED Printer.PARAM_DEFAULT
addImage	color	<ul style="list-style-type: none"> Printer.COLOR_1 Printer.PARAM_DEFAULT
	mode	<ul style="list-style-type: none"> Printer.MODE_MONO Printer.MODE_MONO_HIGH_DENSITY Printer.PARAM_DEFAULT
addBarcode	font	<ul style="list-style-type: none"> Printer.FONT_A (default) Printer.FONT_B Printer.PARAM_DEFAULT Printer.PARAM_UNSPECIFIED

API	Parameter	Specifiable Setting Value
addSymbol	type	<ul style="list-style-type: none"> • Printer.SYMBOL_PDF417_STANDARD • Printer.SYMBOL_PDF417_TRUNCATED • Printer.SYMBOL_QRCODE_MODEL_1 • Printer.SYMBOL_QRCODE_MODEL_2 • Printer.SYMBOL_MAXICODE_MODE_2 • Printer.SYMBOL_MAXICODE_MODE_3 • Printer.SYMBOL_MAXICODE_MODE_4 • Printer.SYMBOL_MAXICODE_MODE_5 • Printer.SYMBOL_MAXICODE_MODE_6 • Printer.SYMBOL_GS1_DATABAR_STACKED • Printer.SYMBOL_GS1_DATABAR_STACKED_OMNIDIRECTIONAL • Printer.SYMBOL_GS1_DATABAR_EXPANDED_STACKED • Printer.SYMBOL_AZTECCODE_FULLRANGE • Printer.SYMBOL_AZTECCODE_COMPACT • Printer.SYMBOL_DATAMATRIX_SQUARE • Printer.SYMBOL_DATAMATRIX_RECTANGLE_8 • Printer.SYMBOL_DATAMATRIX_RECTANGLE_12 • Printer.SYMBOL_DATAMATRIX_RECTANGLE_16
addPageLine	lineStyle	<ul style="list-style-type: none"> • Printer.LINE_THIN • Printer.LINE_MEDIUM • Printer.LINE_THICK • Printer.PARAM_DEFAULT
addPageRectangle	lineStyle	<ul style="list-style-type: none"> • Printer.LINE_THIN • Printer.LINE_MEDIUM • Printer.LINE_THICK • Printer.PARAM_DEFAULT
addCut	type	<ul style="list-style-type: none"> • Printer.CUT_FEED • Printer.CUT_NO_FEED • Printer.PARAM_DEFAULT

API	Parameter	Specifiable Setting Value
addSound	pattern	<ul style="list-style-type: none"> • Printer.PATTERN_NONE • Printer.PATTERN_1 • Printer.PATTERN_2 • Printer.PATTERN_3 • Printer.PATTERN_4 • Printer.PATTERN_5 • Printer.PATTERN_6 • Printer.PATTERN_7 • Printer.PATTERN_8 • Printer.PATTERN_9 • Printer.PATTERN_10 • Printer.PARAM_DEFAULT
	repeat	<ul style="list-style-type: none"> • 1 to 255 • Printer.PARAM_DEFAULT
addFeedPosition	position	<ul style="list-style-type: none"> • Printer.FEED_CUTTING • Printer.FEED_CURRENT_TOF • Printer.FEED_NEXT_TOF
addLayout	type	<ul style="list-style-type: none"> • Printer.LAYOUT_RECEIPT • Printer.LAYOUT_RECEIPT_BM
	height	<ul style="list-style-type: none"> • Receipt (without black mark) • Receipt (with black mark)
	marginTop	<ul style="list-style-type: none"> • Receipt (without black mark) • Receipt (with black mark)
	marginBottom	<ul style="list-style-type: none"> • Receipt (without black mark) • Receipt (with black mark)
	offsetCut	<ul style="list-style-type: none"> • Receipt (without black mark) • Receipt (with black mark)
	offsetLabel	<ul style="list-style-type: none"> • Receipt (without black mark) • Receipt (with black mark)

TM-H6000V**Printer Specifications**

Item	Receipt	Slip	Validation	Endorsement	Endorsement (40cpl)
Amount of initial feed	30 dots	24 dots			18 dots
Initial page mode area	512 x 1662 dots	540 x 1408 dots		-	
Maximum page mode area	512 x 2400 dots	540 x 1408 dots		-	
Baseline of Font A	21 dots from the top of the character	9 dots from the top of the character			7 dots from the top of the character
Baseline of Font B	21 dots from the top of the character	9 dots from the top of the character			-
Baseline of Font C	18 dots from the top of the character	-			

Parameter Restrictions

API	Parameter	Specificable Setting Value
Printer	printerSeries	<ul style="list-style-type: none"> Printer.TM_H6000
	lang	<ul style="list-style-type: none"> Printer.MODEL_ANK Printer.MODEL_TAIWAN
addTextLang	lang	<ul style="list-style-type: none"> Printer.LANG_EN (default) Printer.LANG_JA Printer.LANG_ZH_CN Printer.LANG_ZH_TW Printer.LANG_KO Printer.LANG_TH Printer.LANG_VI Printer.PARAM_DEFAULT
addTextFont	font	<ul style="list-style-type: none"> Printer.FONT_A (default) Printer.FONT_B Printer.FONT_C Printer.PARAM_DEFAULT

API	Parameter	Specifiable Setting Value
addTextStyle	color	<ul style="list-style-type: none"> • Printer.COLOR_1 (default) • Printer.PARAM_UNSPECIFIED • Printer.PARAM_DEFAULT
addImage	color	<ul style="list-style-type: none"> • Printer.COLOR_1 • Printer.PARAM_DEFAULT
addBarcode	font	<ul style="list-style-type: none"> • Printer.FONT_A (default) • Printer.FONT_B • Printer.FONT_C • Printer.PARAM_DEFAULT • Printer.PARAM_UNSPECIFIED
addSymbol	type	<ul style="list-style-type: none"> • Printer.SYMBOL_PDF417_STANDARD • Printer.SYMBOL_PDF417_TRUNCATED • Printer.SYMBOL_QRCODE_MODEL_1 • Printer.SYMBOL_QRCODE_MODEL_2 • Printer.SYMBOL_MAXICODE_MODE_2 • Printer.SYMBOL_MAXICODE_MODE_3 • Printer.SYMBOL_MAXICODE_MODE_4 • Printer.SYMBOL_MAXICODE_MODE_5 • Printer.SYMBOL_MAXICODE_MODE_6 • Printer.SYMBOL_GS1_DATABAR_STACKED • Printer.SYMBOL_GS1_DATABAR_STACKED_OMNIDIRECTIONAL • Printer.SYMBOL_GS1_DATABAR_EXPANDED_STACKED • Printer.SYMBOL_AZTECCODE_FULLRANGE • Printer.SYMBOL_AZTECCODE_COMPACT • Printer.SYMBOL_DATAMATRIX_SQUARE • Printer.SYMBOL_DATAMATRIX_RECTANGLE_8 • Printer.SYMBOL_DATAMATRIX_RECTANGLE_12 • Printer.SYMBOL_DATAMATRIX_RECTANGLE_16
addPageLine	lineStyle	<ul style="list-style-type: none"> • Printer.LINE_THIN • Printer.LINE_MEDIUM • Printer.LINE_THICK
addPageRectangle	lineStyle	<ul style="list-style-type: none"> • Printer.LINE_THIN • Printer.LINE_MEDIUM • Printer.LINE_THICK • Printer.PARAM_DEFAULT
addCut	type	<ul style="list-style-type: none"> • Printer.CUT_FEED • Printer.CUT_NO_FEED • Printer.PARAM_DEFAULT
LineDisplay	displaySeries	<ul style="list-style-type: none"> • LineDisplay.DM_D110 • LineDisplay.DM_D210

TM-T20II-i

Printer Specifications

Item	58mm Specification	80mm Specification
Amount of initial feed	30 dots	
Initial page mode area	420 x 831 dots	576 x 831 dots
Maximum page mode area	420 x 1662 dots	576 x 1662 dots
Baseline of Font A	21 dots from the top of the character	
Baseline of Font B	16 dots from the top of the character	

Parameter Restrictions

API	Parameter	Specificable Setting Value
Printer	printerSeries	<ul style="list-style-type: none"> Printer.TM_T20
	lang	<ul style="list-style-type: none"> Printer.MODEL_ANK
addTextLang	lang	<ul style="list-style-type: none"> Printer.LANG_EN (default) Printer.LANG_JA Printer.LANG_ZH_CN Printer.LANG_ZH_TW Printer.LANG_KO Printer.LANG_TH Printer.LANG_VI Printer.PARAM_DEFAULT
addTextFont	font	<ul style="list-style-type: none"> Printer.FONT_A (default) Printer.FONT_B Printer.PARAM_DEFAULT
addTextStyle	color	<ul style="list-style-type: none"> Printer.COLOR_1 (default) Printer.PARAM_UNSPECIFIED Printer.PARAM_DEFAULT
addImage	color	<ul style="list-style-type: none"> Printer.COLOR_1 Printer.PARAM_DEFAULT
	mode	<ul style="list-style-type: none"> Printer.MODE_MONO Printer.MODE_MONO_HIGH_DENSITY Printer.PARAM_DEFAULT
addBarcode	font	<ul style="list-style-type: none"> Printer.FONT_A (default) Printer.FONT_B Printer.PARAM_DEFAULT Printer.PARAM_UNSPECIFIED

API	Parameter	Specificable Setting Value
addSymbol	type	<ul style="list-style-type: none"> • Printer.SYMBOL_PDF417_STANDARD • Printer.SYMBOL_PDF417_TRUNCATED • Printer.SYMBOL_QRCODE_MODEL_1 • Printer.SYMBOL_QRCODE_MODEL_2 • Printer.SYMBOL_MAXICODE_MODE_2 • Printer.SYMBOL_MAXICODE_MODE_3 • Printer.SYMBOL_MAXICODE_MODE_4 • Printer.SYMBOL_MAXICODE_MODE_5 • Printer.SYMBOL_MAXICODE_MODE_6 • Printer.SYMBOL_GS1_DATABAR_STACKED • Printer.SYMBOL_GS1_DATABAR_STACKED_OMNIDIRECTIONAL • Printer.SYMBOL_GS1_DATABAR_EXPANDED_STACKED
	level	<ul style="list-style-type: none"> • Printer.LEVEL_0 • Printer.LEVEL_1 • Printer.LEVEL_2 • Printer.LEVEL_3 • Printer.LEVEL_4 • Printer.LEVEL_5 • Printer.LEVEL_6 • Printer.LEVEL_7 • Printer.LEVEL_8 • Printer.LEVEL_L • Printer.LEVEL_M • Printer.LEVEL_Q • Printer.LEVEL_H • Printer.PARAM_DEFAULT • Printer.PARAM_UNSPECIFIED
addCut	type	<ul style="list-style-type: none"> • Printer.CUT_FEED • Printer.CUT_NO_FEED • Printer.PARAM_DEFAULT
addSound	pattern	<ul style="list-style-type: none"> • Printer.PATTERN_NONE • Printer.PATTERN_A • Printer.PATTERN_B • Printer.PATTERN_C • Printer.PATTERN_D • Printer.PATTERN_E • Printer.PATTERN_ERROR • Printer.PATTERN_PAPER_EMPTY • Printer.PARAM_DEFAULT
LineDisplay	displaySeries	<ul style="list-style-type: none"> • LineDisplay.DM_D110

TM-T70-i**Printer Specifications**

Item		58mm Specification	80mm Specification
Amount of initial feed		30 dots	
Initial page mode area	ANK model	416 x 1662 dots	512 x 831 dots
	Multiple languages model	416 x 1662 dots	576 x 1662 dots
Maximum page mode area	ANK model	416 x 1662 dots	512 x 1662 dots
	Multiple languages model	416 x 1662 dots	576 x 1662 dots
Baseline of Font A		21 dots from the top of the character	
Baseline of Font B		16 dots from the top of the character	

Parameter Restrictions

API	Parameter	Specificable Setting Value
Printer	printerSeries	<ul style="list-style-type: none"> Printer.TM_T70
	lang	<ul style="list-style-type: none"> Printer.MODEL_ANK Printer.MODEL_CHINESE Printer.MODEL_TAIWAN
addTextLang	lang	<ul style="list-style-type: none"> Printer.LANG_EN (default) Printer.LANG_JA Printer.LANG_ZH_CN Printer.LANG_ZH_TW Printer.LANG_KO Printer.LANG_TH Printer.LANG_VI Printer.PARAM_DEFAULT
addTextFont	font	<ul style="list-style-type: none"> Printer.FONT_A (default) Printer.FONT_B Printer.PARAM_DEFAULT
addTextStyle	color	<ul style="list-style-type: none"> Printer.COLOR_1 (default) Printer.PARAM_UNSPECIFIED Printer.PARAM_DEFAULT
addImage	color	<ul style="list-style-type: none"> Printer.COLOR_1 Printer.PARAM_DEFAULT
	mode	<ul style="list-style-type: none"> Printer.MODE_MONO Printer.MODE_MONO_HIGH_DENSITY Printer.PARAM_DEFAULT

API	Parameter	Specifiable Setting Value
addBarcode	type	<ul style="list-style-type: none"> • Printer.BARCODE_UPC_A • Printer.BARCODE_UPC_E • Printer.BARCODE_EAN13 • Printer.BARCODE_JAN13 • Printer.BARCODE_EAN8 • Printer.BARCODE_JAN8 • Printer.BARCODE_CODE39 • Printer.BARCODE_ITF • Printer.BARCODE_CODABAR • Printer.BARCODE_CODE93 • Printer.BARCODE_CODE128
	font	<ul style="list-style-type: none"> • Printer.FONT_A (default) • Printer.FONT_B • Printer.PARAM_DEFAULT • Printer.PARAM_UNSPECIFIED
addSymbol	type	<ul style="list-style-type: none"> • Printer.SYMBOL_PDF417_STANDARD • Printer.SYMBOL_PDF417_TRUNCATED • Printer.SYMBOL_QRCODE_MODEL_1 • Printer.SYMBOL_QRCODE_MODEL_2
	level	<ul style="list-style-type: none"> • Printer.LEVEL_0 • Printer.LEVEL_1 • Printer.LEVEL_2 • Printer.LEVEL_3 • Printer.LEVEL_4 • Printer.LEVEL_5 • Printer.LEVEL_6 • Printer.LEVEL_7 • Printer.LEVEL_8 • Printer.LEVEL_L • Printer.LEVEL_M • Printer.LEVEL_Q • Printer.LEVEL_H • Printer.PARAM_DEFAULT • Printer.PARAM_UNSPECIFIED
addCut	type	<ul style="list-style-type: none"> • Printer.CUT_FEED • Printer.CUT_NO_FEED • Printer.PARAM_DEFAULT
LineDisplay	displaySeries	<ul style="list-style-type: none"> • LineDisplay.DM_D110

TM-T82II-i

Printer Specifications

Item	Specification
Amount of initial feed	30 dots
Initial page mode area	576 x 831 dots
Maximum page mode area	576 x 1662 dots
Baseline of Font A	21 dots from the top of the character
Baseline of Font B	16 dots from the top of the character

Parameter Restrictions

API	Parameter	Specificable Setting Value
Printer	printerSeries	<ul style="list-style-type: none"> Printer.TM_T82
	lang	<ul style="list-style-type: none"> Printer.MODEL_ANK Printer.MODEL_CHINESE Printer.MODEL_TAIWAN Printer.MODEL_SOUTHASIA
addTextLang	lang	<ul style="list-style-type: none"> Printer.LANG_EN (default) Printer.LANG_JA Printer.LANG_ZH_CN Printer.LANG_ZH_TW Printer.LANG_KO Printer.LANG_TH Printer.LANG_VI Printer.PARAM_DEFAULT
addTextFont	font	<ul style="list-style-type: none"> Printer.FONT_A (default) Printer.FONT_B Printer.PARAM_DEFAULT
addTextStyle	color	<ul style="list-style-type: none"> Printer.COLOR_1 (default) Printer.PARAM_UNSPECIFIED Printer.PARAM_DEFAULT
addImage	color	<ul style="list-style-type: none"> Printer.COLOR_1 Printer.PARAM_DEFAULT
	mode	<ul style="list-style-type: none"> Printer.MODE_MONO Printer.MODE_MONO_HIGH_DENSITY Printer.PARAM_DEFAULT
addBarcode	font	<ul style="list-style-type: none"> Printer.FONT_A (default) Printer.FONT_B Printer.PARAM_DEFAULT Printer.PARAM_UNSPECIFIED

API	Parameter	Specifiable Setting Value
addSymbol	type	<ul style="list-style-type: none"> • Printer.SYMBOL_PDF417_STANDARD • Printer.SYMBOL_PDF417_TRUNCATED • Printer.SYMBOL_QRCODE_MODEL_1 • Printer.SYMBOL_QRCODE_MODEL_2 • Printer.SYMBOL_MAXICODE_MODE_2 • Printer.SYMBOL_MAXICODE_MODE_3 • Printer.SYMBOL_MAXICODE_MODE_4 • Printer.SYMBOL_MAXICODE_MODE_5 • Printer.SYMBOL_MAXICODE_MODE_6 • Printer.SYMBOL_GS1_DATABAR_STACKED • Printer.SYMBOL_GS1_DATABAR_STACKED_OMNIDIRECTIONAL • Printer.SYMBOL_GS1_DATABAR_EXPANDED_STACKED
	level	<ul style="list-style-type: none"> • Printer.LEVEL_0 • Printer.LEVEL_1 • Printer.LEVEL_2 • Printer.LEVEL_3 • Printer.LEVEL_4 • Printer.LEVEL_5 • Printer.LEVEL_6 • Printer.LEVEL_7 • Printer.LEVEL_8 • Printer.LEVEL_L • Printer.LEVEL_M • Printer.LEVEL_Q • Printer.LEVEL_H • Printer.PARAM_DEFAULT • Printer.PARAM_UNSPECIFIED
addCut	type	<ul style="list-style-type: none"> • Printer.CUT_FEED • Printer.CUT_NO_FEED • Printer.PARAM_DEFAULT
addSound	pattern	<ul style="list-style-type: none"> • Printer.PATTERN_NONE • Printer.PATTERN_A • Printer.PATTERN_B • Printer.PATTERN_C • Printer.PATTERN_D • Printer.PATTERN_E • Printer.PATTERN_ERROR • Printer.PATTERN_PAPER_EMPTY • Printer.PARAM_DEFAULT
LineDisplay	displaySeries	<ul style="list-style-type: none"> • LineDisplay.DM_D110

TM-T83II-i**Printer Specifications**

Item		Specification
Amount of initial feed		30 dots
Initial page mode area		512 x 1662 dots
Maximum page mode area		512 x 1662 dots
Baseline of Font A		21 dots from the top of the character
Baseline of Font B	ANK	16 dots from the top of the character
	Chinese characters	15 dots from the top of the character

Parameter Restrictions

API	Parameter	Specificable Setting Value
Printer	printerSeries	<ul style="list-style-type: none"> Printer.TM_T83
	lang	<ul style="list-style-type: none"> Printer.MODEL_KOREAN
addTextLang	lang	<ul style="list-style-type: none"> Printer.LANG_EN (default) Printer.LANG_JA Printer.LANG_ZH_CN Printer.LANG_ZH_TW Printer.LANG_KO Printer.LANG_TH Printer.LANG_VI Printer.PARAM_DEFAULT
addTextFont	font	<ul style="list-style-type: none"> Printer.FONT_A (default) Printer.FONT_B Printer.PARAM_DEFAULT
addTextStyle	color	<ul style="list-style-type: none"> Printer.COLOR_1 (default) Printer.PARAM_UNSPECIFIED Printer.PARAM_DEFAULT
addImage	color	<ul style="list-style-type: none"> Printer.COLOR_1 Printer.PARAM_DEFAULT
	mode	<ul style="list-style-type: none"> Printer.MODE_MONO Printer.MODE_MONO_HIGH_DENSITY Printer.PARAM_DEFAULT
addBarcode	font	<ul style="list-style-type: none"> Printer.FONT_A (default) Printer.FONT_B Printer.PARAM_DEFAULT Printer.PARAM_UNSPECIFIED

API	Parameter	Specificable Setting Value
addSymbol	type	<ul style="list-style-type: none"> • Printer.SYMBOL_PDF417_STANDARD • Printer.SYMBOL_PDF417_TRUNCATED • Printer.SYMBOL_QRCODE_MODEL_1 • Printer.SYMBOL_QRCODE_MODEL_2 • Printer.SYMBOL_MAXICODE_MODE_2 • Printer.SYMBOL_MAXICODE_MODE_3 • Printer.SYMBOL_MAXICODE_MODE_4 • Printer.SYMBOL_MAXICODE_MODE_5 • Printer.SYMBOL_MAXICODE_MODE_6 • Printer.SYMBOL_GS1_DATABAR_STACKED • Printer.SYMBOL_GS1_DATABAR_STACKED_OMNIDIRECTIONAL • Printer.SYMBOL_GS1_DATABAR_EXPANDED_STACKED
	level	<ul style="list-style-type: none"> • Printer.LEVEL_0 • Printer.LEVEL_1 • Printer.LEVEL_2 • Printer.LEVEL_3 • Printer.LEVEL_4 • Printer.LEVEL_5 • Printer.LEVEL_6 • Printer.LEVEL_7 • Printer.LEVEL_8 • Printer.LEVEL_L • Printer.LEVEL_M • Printer.LEVEL_Q • Printer.LEVEL_H • Printer.PARAM_DEFAULT • Printer.PARAM_UNSPECIFIED
addCut	type	<ul style="list-style-type: none"> • Printer.CUT_FEED • Printer.CUT_NO_FEED • Printer.PARAM_DEFAULT
addSound	pattern	<ul style="list-style-type: none"> • Printer.PATTERN_NONE • Printer.PATTERN_A • Printer.PATTERN_B • Printer.PATTERN_C • Printer.PATTERN_D • Printer.PATTERN_E • Printer.PATTERN_ERROR • Printer.PATTERN_PAPER_EMPTY • Printer.PARAM_DEFAULT
LineDisplay	displaySeries	<ul style="list-style-type: none"> • LineDisplay.DM_D110

TM-T88V-i**Printer Specifications**

Item		58mm Specification	80mm Specification
Amount of initial feed		30 dots	
Initial page mode area		360 x 831 dots	512 x 831 dots
Maximum page mode area		360 x 1662 dots	512 x 1662 dots
Baseline of Font A		21 dots from the top of the character	
Baseline of Font B	ANK	16 dots from the top of the character	
	Chinese characters	15 dots from the top of the character	

Parameter Restrictions

API	Parameter	Specificable Setting Value
Printer	printerSeries	<ul style="list-style-type: none"> Printer.TM_T88
	lang	<ul style="list-style-type: none"> Printer.MODEL_ANK Printer.MODEL_CHINESE Printer.MODEL_TAIWAN Printer.MODEL_KOREAN Printer.MODEL_SOUTHASIA
addTextLang	lang	<ul style="list-style-type: none"> Printer.LANG_EN (default) Printer.LANG_JA Printer.LANG_ZH_CN Printer.LANG_ZH_TW Printer.LANG_KO Printer.LANG_TH Printer.LANG_VI Printer.PARAM_DEFAULT
addTextFont	font	<ul style="list-style-type: none"> Printer.FONT_A (default) Printer.FONT_B Printer.PARAM_DEFAULT
addTextStyle	color	<ul style="list-style-type: none"> Printer.COLOR_1 (default) Printer.PARAM_UNSPECIFIED Printer.PARAM_DEFAULT
addImage	color	<ul style="list-style-type: none"> Printer.COLOR_1 Printer.PARAM_DEFAULT
addBarcode	font	<ul style="list-style-type: none"> Printer.FONT_A (default) Printer.FONT_B Printer.PARAM_DEFAULT Printer.PARAM_UNSPECIFIED

API	Parameter	Specificable Setting Value
addSymbol	type	<ul style="list-style-type: none"> • Printer.SYMBOL_PDF417_STANDARD • Printer.SYMBOL_PDF417_TRUNCATED • Printer.SYMBOL_QRCODE_MODEL_1 • Printer.SYMBOL_QRCODE_MODEL_2 • Printer.SYMBOL_MAXICODE_MODE_2 • Printer.SYMBOL_MAXICODE_MODE_3 • Printer.SYMBOL_MAXICODE_MODE_4 • Printer.SYMBOL_MAXICODE_MODE_5 • Printer.SYMBOL_MAXICODE_MODE_6 • Printer.SYMBOL_GS1_DATABAR_STACKED • Printer.SYMBOL_GS1_DATABAR_STACKED_OMNIDIRECTIONAL • Printer.SYMBOL_GS1_DATABAR_EXPANDED_STACKED
	level	<ul style="list-style-type: none"> • Printer.LEVEL_0 • Printer.LEVEL_1 • Printer.LEVEL_2 • Printer.LEVEL_3 • Printer.LEVEL_4 • Printer.LEVEL_5 • Printer.LEVEL_6 • Printer.LEVEL_7 • Printer.LEVEL_8 • Printer.LEVEL_L • Printer.LEVEL_M • Printer.LEVEL_Q • Printer.LEVEL_H • Printer.PARAM_DEFAULT • Printer.PARAM_UNSPECIFIED
addCut	type	<ul style="list-style-type: none"> • Printer.CUT_FEED • Printer.CUT_NO_FEED • Printer.PARAM_DEFAULT
addSound	pattern	<ul style="list-style-type: none"> • Printer.PATTERN_NONE • Printer.PATTERN_A • Printer.PATTERN_B • Printer.PATTERN_C • Printer.PATTERN_D • Printer.PATTERN_E • Printer.PATTERN_ERROR • Printer.PATTERN_PAPER_EMPTY • Printer.PARAM_DEFAULT
LineDisplay	displaySeries	<ul style="list-style-type: none"> • LineDisplay.DM_D110

TM-T88VI-iHUB

Printer Specifications

Item		58mm Specification	80mm Specification
Amount of initial feed		30 dots	
Initial page mode area		360 x 831 dots	512 x 831 dots
Maximum page mode area		360 x 1662 dots	512 x 1662 dots
Baseline of Font A		21 dots from the top of the character	
Baseline of Font B	ANK	16 dots from the top of the character	
	Chinese characters	15 dots from the top of the character	

Parameter Restrictions

API	Parameter	Specificable Setting Value
Printer	printerSeries	<ul style="list-style-type: none"> Printer.TM_T88
	lang	<ul style="list-style-type: none"> Printer.MODEL_ANK Printer.MODEL_CHINESE Printer.MODEL_TAIWAN Printer.MODEL_KOREAN Printer.MODEL_SOUTHASIA
addTextLang	lang	<ul style="list-style-type: none"> Printer.LANG_EN (default) Printer.LANG_JA Printer.LANG_ZH_CN Printer.LANG_ZH_TW Printer.LANG_KO Printer.LANG_TH Printer.LANG_VI Printer.PARAM_DEFAULT
addTextFont	font	<ul style="list-style-type: none"> Printer.FONT_A (default) Printer.FONT_B Printer.PARAM_DEFAULT
addTextStyle	color	<ul style="list-style-type: none"> Printer.COLOR_1 (default) Printer.PARAM_UNSPECIFIED Printer.PARAM_DEFAULT
addImage	color	<ul style="list-style-type: none"> Printer.COLOR_1 Printer.PARAM_DEFAULT
addBarcode	font	<ul style="list-style-type: none"> Printer.FONT_A (default) Printer.FONT_B Printer.PARAM_DEFAULT Printer.PARAM_UNSPECIFIED

API	Parameter	Specificable Setting Value
addSymbol	type	<ul style="list-style-type: none"> • Printer.SYMBOL_PDF417_STANDARD • Printer.SYMBOL_PDF417_TRUNCATED • Printer.SYMBOL_QRCODE_MODEL_1 • Printer.SYMBOL_QRCODE_MODEL_2 • Printer.SYMBOL_MAXICODE_MODE_2 • Printer.SYMBOL_MAXICODE_MODE_3 • Printer.SYMBOL_MAXICODE_MODE_4 • Printer.SYMBOL_MAXICODE_MODE_5 • Printer.SYMBOL_MAXICODE_MODE_6 • Printer.SYMBOL_GS1_DATABAR_STACKED • Printer.SYMBOL_GS1_DATABAR_STACKED_OMNIDIRECTIONAL • Printer.SYMBOL_GS1_DATABAR_EXPANDED_STACKED • Printer.SYMBOL_AZTECCODE_FULLRANGE • Printer.SYMBOL_AZTECCODE_COMPACT • Printer.SYMBOL_DATAMATRIX_SQUARE • Printer.SYMBOL_DATAMATRIX_RECTANGLE_8 • Printer.SYMBOL_DATAMATRIX_RECTANGLE_12 • Printer.SYMBOL_DATAMATRIX_RECTANGLE_16
addPageLine	lineStyle	<ul style="list-style-type: none"> • Printer.LINE_THIN • Printer.LINE_MEDIUM • Printer.LINE_THICK • Printer.PARAM_DEFAULT
addPageRectangle	lineStyle	<ul style="list-style-type: none"> • Printer.LINE_THIN • Printer.LINE_MEDIUM • Printer.LINE_THICK • Printer.PARAM_DEFAULT
addCut	type	<ul style="list-style-type: none"> • Printer.CUT_FEED • Printer.CUT_NO_FEED • Printer.PARAM_DEFAULT
addSound	pattern	<ul style="list-style-type: none"> • Printer.PATTERN_NONE • Printer.PATTERN_A • Printer.PATTERN_B • Printer.PATTERN_C • Printer.PATTERN_D • Printer.PATTERN_E • Printer.PATTERN_ERROR • Printer.PATTERN_PAPER_EMPTY • Printer.PARAM_DEFAULT
	repeat	<ul style="list-style-type: none"> • 1 to 255 • Printer.PARAM_DEFAULT

API	Parameter	Specifiable Setting Value
setPrinterSetting	value	<ul style="list-style-type: none"> • Printer.Setting.PaperWidth58_0 • Printer.Setting.PaperWidth80_0 • Printer.Setting.PrintDensityDIP • Printer.Setting.PrintDensity70 • Printer.Setting.PrintDensity75 • Printer.Setting.PrintDensity80 • Printer.Setting.PrintDensity85 • Printer.Setting.PrintDensity90 • Printer.Setting.PrintDensity95 • Printer.Setting.PrintDensity100 • Printer.Setting.PrintDensity105 • Printer.Setting.PrintDensity110 • Printer.Setting.PrintDensity115 • Printer.Setting.PrintDensity120 • Printer.Setting.PrintDensity125 • Printer.Setting.PrintDensity130 • Printer.Setting.PrintSpeed1 • Printer.Setting.PrintSpeed2 • Printer.Setting.PrintSpeed3 • Printer.Setting.PrintSpeed4 • Printer.Setting.PrintSpeed5 • Printer.Setting.PrintSpeed6 • Printer.Setting.PrintSpeed7 • Printer.Setting.PrintSpeed8 • Printer.Setting.PrintSpeed9 • Printer.Setting.PrintSpeed10 • Printer.Setting.PrintSpeed11 • Printer.Setting.PrintSpeed12 • Printer.Setting.PrintSpeed13 • Printer.Setting.PrintSpeed14
downloadFirmwareList	printerModel	<ul style="list-style-type: none"> • TM-T88VI-iHUB
LineDisplay	displaySeries	<ul style="list-style-type: none"> • LineDisplay.DM_D110 • LineDisplay.DM_D30

TM-U220-i

Printer Specifications

Item	76mm Specifi- cation	69.5mm Specifi- cation	57.5mm Specifi- cation
Amount of initial feed	12 dots		

Parameter Restrictions

API	Parameter	Specificable Setting Value
Printer	printerSeries	<ul style="list-style-type: none"> Printer.TM_U220
	lang	<ul style="list-style-type: none"> Printer.MODEL_ANK Printer.MODEL_CHINESE Printer.MODEL_TAIWAN Printer.MODEL_KOREAN Printer.MODEL_THAI
addTextLang	lang	<ul style="list-style-type: none"> Printer.LANG_EN (default) Printer.LANG_JA Printer.LANG_ZH_CN Printer.LANG_ZH_TW Printer.LANG_KO Printer.LANG_TH Printer.LANG_VI Printer.PARAM_DEFAULT
addTextFont	font	<ul style="list-style-type: none"> Printer.FONT_A (default) Printer.FONT_B Printer.PARAM_DEFAULT
addTextStyle	color	<ul style="list-style-type: none"> Printer.COLOR_1 (default) Printer.COLOR_2 Printer.PARAM_UNSPECIFIED Printer.PARAM_DEFAULT
addImage	color	<ul style="list-style-type: none"> Printer.COLOR_1 Printer.COLOR_2 Printer.PARAM_DEFAULT
	mode	<ul style="list-style-type: none"> Printer.MODE_MONO Printer.MODE_MONO_HIGH_DENSITY Printer.PARAM_DEFAULT
addCut	type	<ul style="list-style-type: none"> Printer.CUT_FEED Printer.CUT_NO_FEED Printer.PARAM_DEFAULT
LineDisplay	displaySeries	<ul style="list-style-type: none"> LineDisplay.DM_D110

TM-T70II-DT**Printer Specifications**

Item		58mm Specification	80mm Specification
Amount of initial feed		30 dots	
Initial page mode area	ANK model	416 x 1662 dots	512 x 1662 dots
	Multiple languages model	416 x 1662 dots	576 x 1662 dots
Maximum page mode area	ANK model	416 x 1662 dots	512 x 1662 dots
	Multiple languages model	416 x 1662 dots	576 x 1662 dots
Baseline of Font A		21 dots from the top of the character	
Baseline of Font B		16 dots from the top of the character	

Parameter Restrictions

API	Parameter	Specificable Setting Value
Printer	printerSeries	<ul style="list-style-type: none"> Printer.TM_T70
	lang	<ul style="list-style-type: none"> Printer.MODEL_ANK Printer.MODEL_CHINESE Printer.MODEL_TAIWAN Printer.MODEL_SOUTHASIA
addTextLang	lang	<ul style="list-style-type: none"> Printer.LANG_EN (default) Printer.LANG_JA Printer.LANG_ZH_CN Printer.LANG_ZH_TW Printer.LANG_KO Printer.LANG_TH Printer.LANG_VI Printer.PARAM_DEFAULT
addTextFont	font	<ul style="list-style-type: none"> Printer.FONT_A (default) Printer.FONT_B Printer.PARAM_DEFAULT
addTextStyle	color	<ul style="list-style-type: none"> Printer.COLOR_1 (default) Printer.PARAM_UNSPECIFIED Printer.PARAM_DEFAULT
addImage	color	<ul style="list-style-type: none"> Printer.COLOR_1 Printer.PARAM_DEFAULT

API	Parameter	Specifiable Setting Value
addBarcode	font	<ul style="list-style-type: none"> • Printer.FONT_A (default) • Printer.FONT_B • Printer.PARAM_DEFAULT • Printer.PARAM_UNSPECIFIED
addSymbol	type	<ul style="list-style-type: none"> • Printer.SYMBOL_PDF417_STANDARD • Printer.SYMBOL_PDF417_TRUNCATED • Printer.SYMBOL_QRCODE_MODEL_1 • Printer.SYMBOL_QRCODE_MODEL_2 • Printer.SYMBOL_MAXICODE_MODE_2 • Printer.SYMBOL_MAXICODE_MODE_3 • Printer.SYMBOL_MAXICODE_MODE_4 • Printer.SYMBOL_MAXICODE_MODE_5 • Printer.SYMBOL_MAXICODE_MODE_6 • Printer.SYMBOL_GS1_DATABAR_STACKED • Printer.SYMBOL_GS1_DATABAR_STACKED_OMNIDIRECTIONAL • Printer.SYMBOL_GS1_DATABAR_EXPANDED_STACKED
	level	<ul style="list-style-type: none"> • Printer.LEVEL_0 • Printer.LEVEL_1 • Printer.LEVEL_2 • Printer.LEVEL_3 • Printer.LEVEL_4 • Printer.LEVEL_5 • Printer.LEVEL_6 • Printer.LEVEL_7 • Printer.LEVEL_8 • Printer.LEVEL_L • Printer.LEVEL_M • Printer.LEVEL_Q • Printer.LEVEL_H • Printer.PARAM_DEFAULT • Printer.PARAM_UNSPECIFIED
addCut	type	<ul style="list-style-type: none"> • Printer.CUT_FEED • Printer.CUT_NO_FEED • Printer.PARAM_DEFAULT

API	Parameter	Specificable Setting Value
addSound	pattern	<ul style="list-style-type: none">• Printer.PATTERN_NONE• Printer.PATTERN_A• Printer.PATTERN_B• Printer.PATTERN_C• Printer.PATTERN_D• Printer.PATTERN_E• Printer.PATTERN_ERROR• Printer.PATTERN_PAPER_EMPTY• Printer.PARAM_DEFAULT
LineDisplay	displaySeries	<ul style="list-style-type: none">• LineDisplay.DM_D110• LineDisplay.DM_D30

TM-T70II-DT2**Printer Specifications**

Item		58mm Specification	80mm Specification
Amount of initial feed		30 dots	
Initial page mode area	ANK model	416 x 1662 dots	512 x 1662 dots
	Multiple languages model	416 x 1662 dots	576 x 1662 dots
Maximum page mode area	ANK model	416 x 1662 dots	512 x 1662 dots
	Multiple languages model	416 x 1662 dots	576 x 1662 dots
Baseline of Font A		21 dots from the top of the character	
Baseline of Font B		16 dots from the top of the character	

Parameter Restrictions

API	Parameter	Specificable Setting Value
Printer	printerSeries	<ul style="list-style-type: none"> Printer.TM_T70
	lang	<ul style="list-style-type: none"> Printer.MODEL_ANK Printer.MODEL_CHINESE Printer.MODEL_TAIWAN Printer.MODEL_SOUTHASIA
addTextLang	lang	<ul style="list-style-type: none"> Printer.LANG_EN (default) Printer.LANG_JA Printer.LANG_ZH_CN Printer.LANG_ZH_TW Printer.LANG_KO Printer.LANG_TH Printer.LANG_VI Printer.PARAM_DEFAULT
addTextFont	font	<ul style="list-style-type: none"> Printer.FONT_A (default) Printer.FONT_B Printer.PARAM_DEFAULT
addTextStyle	color	<ul style="list-style-type: none"> Printer.COLOR_1 (default) Printer.PARAM_UNSPECIFIED Printer.PARAM_DEFAULT
addImage	color	<ul style="list-style-type: none"> Printer.COLOR_1 Printer.PARAM_DEFAULT

API	Parameter	Specifiable Setting Value
addBarcode	font	<ul style="list-style-type: none"> • Printer.FONT_A (default) • Printer.FONT_B • Printer.PARAM_DEFAULT • Printer.PARAM_UNSPECIFIED
addSymbol	type	<ul style="list-style-type: none"> • Printer.SYMBOL_PDF417_STANDARD • Printer.SYMBOL_PDF417_TRUNCATED • Printer.SYMBOL_QRCODE_MODEL_1 • Printer.SYMBOL_QRCODE_MODEL_2 • Printer.SYMBOL_MAXICODE_MODE_2 • Printer.SYMBOL_MAXICODE_MODE_3 • Printer.SYMBOL_MAXICODE_MODE_4 • Printer.SYMBOL_MAXICODE_MODE_5 • Printer.SYMBOL_MAXICODE_MODE_6 • Printer.SYMBOL_GS1_DATABAR_STACKED • Printer.SYMBOL_GS1_DATABAR_STACKED_OMNIDIRECTIONAL • Printer.SYMBOL_GS1_DATABAR_EXPANDED_STACKED
	level	<ul style="list-style-type: none"> • Printer.LEVEL_0 • Printer.LEVEL_1 • Printer.LEVEL_2 • Printer.LEVEL_3 • Printer.LEVEL_4 • Printer.LEVEL_5 • Printer.LEVEL_6 • Printer.LEVEL_7 • Printer.LEVEL_8 • Printer.LEVEL_L • Printer.LEVEL_M • Printer.LEVEL_Q • Printer.LEVEL_H • Printer.PARAM_DEFAULT • Printer.PARAM_UNSPECIFIED
addCut	type	<ul style="list-style-type: none"> • Printer.CUT_FEED • Printer.CUT_NO_FEED • Printer.PARAM_DEFAULT

API	Parameter	Specificable Setting Value
addSound	pattern	<ul style="list-style-type: none"> • Printer.PATTERN_NONE • Printer.PATTERN_A • Printer.PATTERN_B • Printer.PATTERN_C • Printer.PATTERN_D • Printer.PATTERN_E • Printer.PATTERN_ERROR • Printer.PATTERN_PAPER_EMPTY • Printer.PARAM_DEFAULT
LineDisplay	displaySeries	<ul style="list-style-type: none"> • LineDisplay.DM_D110 • LineDisplay.DM_D30

TM-T88V-DT

Printer Specifications

Item		58mm Specification	80mm Specification
Amount of initial feed		30 dots	
Initial page mode area		360 x 831 dots	512 x 831 dots
Maximum page mode area		360 x 1662 dots	512 x 1662 dots
Baseline of Font A		21 dots from the top of the character	
Baseline of Font B	ANK	16 dots from the top of the character	
	Chinese characters	15 dots from the top of the character	

Parameter Restrictions

API	Parameter	Specificable Setting Value
Printer	printerSeries	<ul style="list-style-type: none"> Printer.TM_T88
	lang	<ul style="list-style-type: none"> Printer.MODEL_ANK Printer.MODEL_CHINESE Printer.MODEL_TAIWAN Printer.MODEL_KOREAN Printer.MODEL_SOUTHASIA
addTextLang	lang	<ul style="list-style-type: none"> Printer.LANG_EN (default) Printer.LANG_JA Printer.LANG_ZH_CN Printer.LANG_ZH_TW Printer.LANG_KO Printer.LANG_TH Printer.LANG_VI Printer.PARAM_DEFAULT
addTextFont	font	<ul style="list-style-type: none"> Printer.FONT_A (default) Printer.FONT_B Printer.PARAM_DEFAULT
addTextStyle	color	<ul style="list-style-type: none"> Printer.COLOR_1 (default) Printer.PARAM_UNSPECIFIED Printer.PARAM_DEFAULT
addImage	color	<ul style="list-style-type: none"> Printer.COLOR_1 Printer.PARAM_DEFAULT
addBarcode	font	<ul style="list-style-type: none"> Printer.FONT_A (default) Printer.FONT_B Printer.PARAM_DEFAULT Printer.PARAM_UNSPECIFIED

API	Parameter	Specificable Setting Value
addSymbol	type	<ul style="list-style-type: none"> • Printer.SYMBOL_PDF417_STANDARD • Printer.SYMBOL_PDF417_TRUNCATED • Printer.SYMBOL_QRCODE_MODEL_1 • Printer.SYMBOL_QRCODE_MODEL_2 • Printer.SYMBOL_MAXICODE_MODE_2 • Printer.SYMBOL_MAXICODE_MODE_3 • Printer.SYMBOL_MAXICODE_MODE_4 • Printer.SYMBOL_MAXICODE_MODE_5 • Printer.SYMBOL_MAXICODE_MODE_6 • Printer.SYMBOL_GS1_DATABAR_STACKED • Printer.SYMBOL_GS1_DATABAR_STACKED_OMNIDIRECTIONAL • Printer.SYMBOL_GS1_DATABAR_EXPANDED_STACKED
	level	<ul style="list-style-type: none"> • Printer.LEVEL_0 • Printer.LEVEL_1 • Printer.LEVEL_2 • Printer.LEVEL_3 • Printer.LEVEL_4 • Printer.LEVEL_5 • Printer.LEVEL_6 • Printer.LEVEL_7 • Printer.LEVEL_8 • Printer.LEVEL_L • Printer.LEVEL_M • Printer.LEVEL_Q • Printer.LEVEL_H • Printer.PARAM_DEFAULT • Printer.PARAM_UNSPECIFIED
addCut	type	<ul style="list-style-type: none"> • Printer.CUT_FEED • Printer.CUT_NO_FEED • Printer.PARAM_DEFAULT
addSound	pattern	<ul style="list-style-type: none"> • Printer.PATTERN_NONE • Printer.PATTERN_A • Printer.PATTERN_B • Printer.PATTERN_C • Printer.PATTERN_D • Printer.PATTERN_E • Printer.PATTERN_ERROR • Printer.PATTERN_PAPER_EMPTY • Printer.PARAM_DEFAULT
LineDisplay	displaySeries	<ul style="list-style-type: none"> • LineDisplay.DM_D110 • LineDisplay.DM_D30

TM-T88VI-DT2

Printer Specifications

Item		58mm Specification	80mm Specification
Amount of initial feed		30 dots	
Initial page mode area		360 x 831 dots	512 x 831 dots
Maximum page mode area		360 x 1662 dots	512 x 1662 dots
Baseline of Font A		21 dots from the top of the character	
Baseline of Font B	ANK	16 dots from the top of the character	
	Chinese characters	15 dots from the top of the character	

Parameter Restrictions

API	Parameter	Specificable Setting Value
Printer	printerSeries	<ul style="list-style-type: none"> Printer.TM_T88
	lang	<ul style="list-style-type: none"> Printer.MODEL_ANK Printer.MODEL_CHINESE Printer.MODEL_TAIWAN Printer.MODEL_KOREAN Printer.MODEL_SOUTHASIA
addTextLang	lang	<ul style="list-style-type: none"> Printer.LANG_EN (default) Printer.LANG_JA Printer.LANG_ZH_CN Printer.LANG_ZH_TW Printer.LANG_KO Printer.LANG_TH Printer.LANG_VI Printer.PARAM_DEFAULT
addTextFont	font	<ul style="list-style-type: none"> Printer.FONT_A (default) Printer.FONT_B Printer.PARAM_DEFAULT
addTextStyle	color	<ul style="list-style-type: none"> Printer.COLOR_1 (default) Printer.PARAM_UNSPECIFIED Printer.PARAM_DEFAULT
addImage	color	<ul style="list-style-type: none"> Printer.COLOR_1 Printer.PARAM_DEFAULT
addBarcode	font	<ul style="list-style-type: none"> Printer.FONT_A (default) Printer.FONT_B Printer.PARAM_DEFAULT Printer.PARAM_UNSPECIFIED

API	Parameter	Specifiable Setting Value
addSymbol	type	<ul style="list-style-type: none"> • Printer.SYMBOL_PDF417_STANDARD • Printer.SYMBOL_PDF417_TRUNCATED • Printer.SYMBOL_QRCODE_MODEL_1 • Printer.SYMBOL_QRCODE_MODEL_2 • Printer.SYMBOL_MAXICODE_MODE_2 • Printer.SYMBOL_MAXICODE_MODE_3 • Printer.SYMBOL_MAXICODE_MODE_4 • Printer.SYMBOL_MAXICODE_MODE_5 • Printer.SYMBOL_MAXICODE_MODE_6 • Printer.SYMBOL_GS1_DATABAR_STACKED • Printer.SYMBOL_GS1_DATABAR_STACKED_OMNIDIRECTIONAL • Printer.SYMBOL_GS1_DATABAR_EXPANDED_STACKED • Printer.SYMBOL_AZTECCODE_FULLRANGE • Printer.SYMBOL_AZTECCODE_COMPACT • Printer.SYMBOL_DATAMATRIX_SQUARE • Printer.SYMBOL_DATAMATRIX_RECTANGLE_8 • Printer.SYMBOL_DATAMATRIX_RECTANGLE_12 • Printer.SYMBOL_DATAMATRIX_RECTANGLE_16
addCut	type	<ul style="list-style-type: none"> • Printer.CUT_FEED • Printer.CUT_NO_FEED • Printer.PARAM_DEFAULT
addSound	pattern	<ul style="list-style-type: none"> • Printer.PATTERN_NONE • Printer.PATTERN_A • Printer.PATTERN_B • Printer.PATTERN_C • Printer.PATTERN_D • Printer.PATTERN_E • Printer.PATTERN_ERROR • Printer.PATTERN_PAPER_EMPTY • Printer.PARAM_DEFAULT
LineDisplay	displaySeries	<ul style="list-style-type: none"> • LineDisplay.DM_D110 • LineDisplay.DM_D30

TM-H6000IV-DT

Printer Specifications

Item	58mm Specification	80mm Specification
Amount of initial feed	30 dots	
Initial page mode area	360 x 831 dots	512 x 831 dots
Maximum page mode area	360 x 1662 dots	512 x 1662 dots
Baseline of Font A	21 dots from the top of the character	
Baseline of Font B	16 dots from the top of the character	

Parameter Restrictions

API	Parameter	Specifiable Setting Value
Printer	printerSeries	<ul style="list-style-type: none"> Printer.TM_H6000
	lang	<ul style="list-style-type: none"> Printer.MODEL_CHINESE Printer.MODEL_TAIWAN
addTextLang	lang	<ul style="list-style-type: none"> Printer.LANG_EN (default) Printer.LANG_JA Printer.LANG_ZH_CN Printer.LANG_ZH_TW Printer.LANG_KO Printer.LANG_TH Printer.LANG_VI Printer.PARAM_DEFAULT
addTextFont	font	<ul style="list-style-type: none"> Printer.FONT_A (default) Printer.FONT_B Printer.PARAM_DEFAULT
addTextStyle	color	<ul style="list-style-type: none"> Printer.COLOR_1 (default) Printer.PARAM_UNSPECIFIED Printer.PARAM_DEFAULT
addImage	color	<ul style="list-style-type: none"> Printer.COLOR_1 Printer.PARAM_DEFAULT
addBarcode	font	<ul style="list-style-type: none"> Printer.FONT_A (default) Printer.FONT_B Printer.PARAM_DEFAULT Printer.PARAM_UNSPECIFIED

API	Parameter	Specifiable Setting Value
addSymbol	type	<ul style="list-style-type: none"> • Printer.SYMBOL_PDF417_STANDARD • Printer.SYMBOL_PDF417_TRUNCATED • Printer.SYMBOL_QRCODE_MODEL_1 • Printer.SYMBOL_QRCODE_MODEL_2 • Printer.SYMBOL_MAXICODE_MODE_2 • Printer.SYMBOL_MAXICODE_MODE_3 • Printer.SYMBOL_MAXICODE_MODE_4 • Printer.SYMBOL_MAXICODE_MODE_5 • Printer.SYMBOL_MAXICODE_MODE_6 • Printer.SYMBOL_GS1_DATABAR_STACKED • Printer.SYMBOL_GS1_DATABAR_STACKED_OMNIDIRECTIONAL • Printer.SYMBOL_GS1_DATABAR_EXPANDED_STACKED
	level	<ul style="list-style-type: none"> • Printer.LEVEL_0 • Printer.LEVEL_1 • Printer.LEVEL_2 • Printer.LEVEL_3 • Printer.LEVEL_4 • Printer.LEVEL_5 • Printer.LEVEL_6 • Printer.LEVEL_7 • Printer.LEVEL_8 • Printer.LEVEL_L • Printer.LEVEL_M • Printer.LEVEL_Q • Printer.LEVEL_H • Printer.PARAM_DEFAULT • Printer.PARAM_UNSPECIFIED
addCut	type	<ul style="list-style-type: none"> • Printer.CUT_FEED • Printer.CUT_NO_FEED • Printer.PARAM_DEFAULT
LineDisplay	displaySeries	<ul style="list-style-type: none"> • LineDisplay.DM_D110 • LineDisplay.DM_D30

TM-T88IV**Printer Specifications**

Item		58mm Specification	80mm Specification
Amount of initial feed		30 dots	
Initial page mode area	Monochrome printing	360 x 831 dots	512 x 831 dots
	Two-color printing	360 x 415 dots	512 x 415 dots
Maximum page mode area	Monochrome printing	360 x 1662 dots	512 x 1662 dots
	Two-color printing	360 x 831 dots	512 x 831 dots
Baseline of Font A		21 dots from the top of the character	
Baseline of Font B		16 dots from the top of the character	

Parameter Restrictions

API	Parameter	Specificable Setting Value
Printer	printerSeries	<ul style="list-style-type: none"> Printer.TM_T88
	lang	<ul style="list-style-type: none"> Printer.MODEL_ANK Printer.MODEL_CHINESE Printer.MODEL_TAIWAN
addTextLang	lang	<ul style="list-style-type: none"> Printer.LANG_EN (default) Printer.LANG_JA Printer.LANG_ZH_CN Printer.LANG_ZH_TW Printer.LANG_KO Printer.LANG_TH Printer.LANG_VI Printer.PARAM_DEFAULT
addTextFont	font	<ul style="list-style-type: none"> Printer.FONT_A (default) Printer.FONT_B Printer.PARAM_DEFAULT
addTextStyle	color	<ul style="list-style-type: none"> Printer.COLOR_1 (default) Printer.COLOR_2 Printer.PARAM_UNSPECIFIED Printer.PARAM_DEFAULT
addImage	color	<ul style="list-style-type: none"> Printer.COLOR_1 Printer.COLOR_2 Printer.PARAM_DEFAULT

API	Parameter	Specifiable Setting Value
addBarcode	type	<ul style="list-style-type: none"> • Printer.BARCODE_UPC_A • Printer.BARCODE_UPC_E • Printer.BARCODE_EAN13 • Printer.BARCODE_JAN13 • Printer.BARCODE_EAN8 • Printer.BARCODE_JAN8 • Printer.BARCODE_CODE39 • Printer.BARCODE_ITF • Printer.BARCODE_CODABAR • Printer.BARCODE_CODE93 • Printer.BARCODE_CODE128
	font	<ul style="list-style-type: none"> • Printer.FONT_A (default) • Printer.FONT_B • Printer.PARAM_DEFAULT • Printer.PARAM_UNSPECIFIED
addSymbol	type	<ul style="list-style-type: none"> • Printer.SYMBOL_PDF417_STANDARD • Printer.SYMBOL_PDF417_TRUNCATED • Printer.SYMBOL_QRCODE_MODEL_1 • Printer.SYMBOL_QRCODE_MODEL_2
	level	<ul style="list-style-type: none"> • Printer.LEVEL_0 • Printer.LEVEL_1 • Printer.LEVEL_2 • Printer.LEVEL_3 • Printer.LEVEL_4 • Printer.LEVEL_5 • Printer.LEVEL_6 • Printer.LEVEL_7 • Printer.LEVEL_8 • Printer.LEVEL_L • Printer.LEVEL_M • Printer.LEVEL_Q • Printer.LEVEL_H • Printer.PARAM_DEFAULT • Printer.PARAM_UNSPECIFIED
addCut	type	<ul style="list-style-type: none"> • Printer.CUT_FEED • Printer.CUT_NO_FEED • Printer.PARAM_DEFAULT

TM-T90

Printer Specifications

Item		58mm Specification	60mm Specification	80mm Specification
Amount of initial feed		30 dots		
Initial page mode area	Monochrome printing	420 x 738 dots	384 x 831 dots	576 x 738 dots
	Two-color printing	420 x 369 dots	384 x 415 dots	576 x 369 dots
Maximum page mode area	Monochrome printing	420 x 1476 dots	384 x 1662 dots	576 x 1476 dots
	Two-color printing	420 x 738 dots	384 x 831 dots	576 x 738 dots
Baseline of Font A		21 dots from the top of the character		
Baseline of Font B		16 dots from the top of the character		

Parameter Restrictions

API	Parameter	Specificable Setting Value
Printer	printerSeries	<ul style="list-style-type: none"> Printer.TM_T90
	lang	<ul style="list-style-type: none"> Printer.MODEL_ANK Printer.MODEL_CHINESE Printer.MODEL_TAIWAN Printer.MODEL_KOREAN Printer.MODEL_THAI
addTextLang	lang	<ul style="list-style-type: none"> Printer.LANG_EN (default) Printer.LANG_JA Printer.LANG_ZH_CN Printer.LANG_ZH_TW Printer.LANG_KO Printer.LANG_TH Printer.LANG_VI Printer.PARAM_DEFAULT
addTextFont	font	<ul style="list-style-type: none"> Printer.FONT_A (default) Printer.FONT_B Printer.FONT_C Printer.PARAM_DEFAULT
addTextStyle	color	<ul style="list-style-type: none"> Printer.COLOR_1 (default) Printer.COLOR_2 Printer.PARAM_UNSPECIFIED Printer.PARAM_DEFAULT

API	Parameter	Specifiable Setting Value
addImage	color	<ul style="list-style-type: none"> • Printer.COLOR_1 • Printer.COLOR_2 • Printer.PARAM_DEFAULT
addBarcode	type	<ul style="list-style-type: none"> • Printer.BARCODE_UPC_A • Printer.BARCODE_UPC_E • Printer.BARCODE_EAN13 • Printer.BARCODE_JAN13 • Printer.BARCODE_EAN8 • Printer.BARCODE_JAN8 • Printer.BARCODE_CODE39 • Printer.BARCODE_ITF • Printer.BARCODE_CODABAR • Printer.BARCODE_CODE93 • Printer.BARCODE_CODE128
	font	<ul style="list-style-type: none"> • Printer.FONT_A (default) • Printer.FONT_B • Printer.FONT_C • Printer.PARAM_DEFAULT • Printer.PARAM_UNSPECIFIED
addSymbol	type	<ul style="list-style-type: none"> • Printer.SYMBOL_PDF417_STANDARD • Printer.SYMBOL_PDF417_TRUNCATED
	level	<ul style="list-style-type: none"> • Printer.LEVEL_0 • Printer.LEVEL_1 • Printer.LEVEL_2 • Printer.LEVEL_3 • Printer.LEVEL_4 • Printer.LEVEL_5 • Printer.LEVEL_6 • Printer.LEVEL_7 • Printer.LEVEL_8 • Printer.PARAM_DEFAULT • Printer.PARAM_UNSPECIFIED
addCut	type	<ul style="list-style-type: none"> • Printer.CUT_FEED • Printer.CUT_NO_FEED • Printer.PARAM_DEFAULT

TM-L90**Printer Specifications**

Item		Receipt Specification	Die-cut Label Specification
Amount of initial feed		30 dots	
Initial page mode area	Monochrome printing	576 x 738 dots	560 x 738 dots
	Two-color printing	576 x 369 dots	560 x 369 dots
Maximum page mode area	Monochrome printing	576 x 1476 dots	560 x 1476 dots
	Two-color printing	576x 738 dots	560 x 738 dots
Baseline of Font A		21 dots from the top of the character	
Baseline of Font B		ANK: 16 Chinese characters: 15 dots from the top of the character	

Parameter Restrictions

API	Parameter	Specificable Setting Value
Printer	printerSeries	<ul style="list-style-type: none"> Printer.TM_L90
	lang	<ul style="list-style-type: none"> Printer.MODEL_ANK Printer.MODEL_CHINESE Printer.MODEL_TAIWAN Printer.MODEL_KOREAN Printer.MODEL_THAI
addTextLang	lang	<ul style="list-style-type: none"> Printer.LANG_EN (default) Printer.LANG_JA Printer.LANG_ZH_CN Printer.LANG_ZH_TW Printer.LANG_KO Printer.LANG_TH Printer.LANG_VI Printer.PARAM_DEFAULT
addTextFont	font	<ul style="list-style-type: none"> Printer.FONT_A (default) Printer.FONT_B Printer.PARAM_DEFAULT
addTextStyle	color	<ul style="list-style-type: none"> Printer.COLOR_1 (default) Printer.COLOR_2 Printer.PARAM_UNSPECIFIED Printer.PARAM_DEFAULT

API	Parameter	Specifiable Setting Value
addImage	color	<ul style="list-style-type: none"> • Printer.COLOR_1 • Printer.COLOR_2 • Printer.PARAM_DEFAULT
addBarcode	type	<ul style="list-style-type: none"> • Printer.BARCODE_UPC_A • Printer.BARCODE_UPC_E • Printer.BARCODE_EAN13 • Printer.BARCODE_JAN13 • Printer.BARCODE_EAN8 • Printer.BARCODE_JAN8 • Printer.BARCODE_CODE39 • Printer.BARCODE_ITF • Printer.BARCODE_CODABAR • Printer.BARCODE_CODE93 • Printer.BARCODE_CODE128
	font	<ul style="list-style-type: none"> • Printer.FONT_A (default) • Printer.FONT_B • Printer.PARAM_DEFAULT • Printer.PARAM_UNSPECIFIED
addSymbol	type	<ul style="list-style-type: none"> • Printer.SYMBOL_PDF417_STANDARD • Printer.SYMBOL_PDF417_TRUNCATED • Printer.SYMBOL_QRCODE_MODEL_1 • Printer.SYMBOL_QRCODE_MODEL_2 • Printer.SYMBOL_MAXICODE_MODE_2 • Printer.SYMBOL_MAXICODE_MODE_3 • Printer.SYMBOL_MAXICODE_MODE_4 • Printer.SYMBOL_MAXICODE_MODE_5 • Printer.SYMBOL_MAXICODE_MODE_6
	level	<ul style="list-style-type: none"> • Printer.LEVEL_0 • Printer.LEVEL_1 • Printer.LEVEL_2 • Printer.LEVEL_3 • Printer.LEVEL_4 • Printer.LEVEL_5 • Printer.LEVEL_6 • Printer.LEVEL_7 • Printer.LEVEL_8 • Printer.LEVEL_L • Printer.LEVEL_M • Printer.LEVEL_Q • Printer.LEVEL_H • Printer.PARAM_DEFAULT • Printer.PARAM_UNSPECIFIED

API	Parameter	Specifiable Setting Value
addCut	type	<ul style="list-style-type: none">• Printer.CUT_FEED• Printer.CUT_NO_FEED• Printer.PARAM_DEFAULT

TM-H6000IV**Printer Specifications**

Item	58mm Specification	80mm Specification
Amount of initial feed	30 dots	
Initial page mode area	360 x 831 dots	512 x 831 dots
Maximum page mode area	360 x 1662 dots	512 x 1662 dots
Baseline of Font A	21 dots from the top of the character	
Baseline of Font B	16 dots from the top of the character	

Parameter Restrictions

API	Parameter	Specifiable Setting Value
Printer	printerSeries	<ul style="list-style-type: none"> Printer.TM_H6000
	lang	<ul style="list-style-type: none"> Printer.MODEL_CHINESE Printer.MODEL_TAIWAN
addTextLang	lang	<ul style="list-style-type: none"> Printer.LANG_EN (default) Printer.LANG_JA Printer.LANG_ZH_CN Printer.LANG_ZH_TW Printer.LANG_KO Printer.LANG_TH Printer.LANG_VI Printer.PARAM_DEFAULT
addTextFont	font	<ul style="list-style-type: none"> Printer.FONT_A (default) Printer.FONT_B Printer.PARAM_DEFAULT
addTextStyle	color	<ul style="list-style-type: none"> Printer.COLOR_1 (default) Printer.PARAM_UNSPECIFIED Printer.PARAM_DEFAULT
addImage	color	<ul style="list-style-type: none"> Printer.COLOR_1 Printer.PARAM_DEFAULT
addBarcode	font	<ul style="list-style-type: none"> Printer.FONT_A (default) Printer.FONT_B Printer.PARAM_DEFAULT Printer.PARAM_UNSPECIFIED

API	Parameter	Specifiable Setting Value
addSymbol	type	<ul style="list-style-type: none"> • Printer.SYMBOL_PDF417_STANDARD • Printer.SYMBOL_PDF417_TRUNCATED • Printer.SYMBOL_QRCODE_MODEL_1 • Printer.SYMBOL_QRCODE_MODEL_2 • Printer.SYMBOL_MAXICODE_MODE_2 • Printer.SYMBOL_MAXICODE_MODE_3 • Printer.SYMBOL_MAXICODE_MODE_4 • Printer.SYMBOL_MAXICODE_MODE_5 • Printer.SYMBOL_MAXICODE_MODE_6 • Printer.SYMBOL_GS1_DATABAR_STACKED • Printer.SYMBOL_GS1_DATABAR_STACKED_OMNIDIRECTIONAL • Printer.SYMBOL_GS1_DATABAR_EXPANDED_STACKED
	level	<ul style="list-style-type: none"> • Printer.LEVEL_0 • Printer.LEVEL_1 • Printer.LEVEL_2 • Printer.LEVEL_3 • Printer.LEVEL_4 • Printer.LEVEL_5 • Printer.LEVEL_6 • Printer.LEVEL_7 • Printer.LEVEL_8 • Printer.LEVEL_L • Printer.LEVEL_M • Printer.LEVEL_Q • Printer.LEVEL_H • Printer.PARAM_DEFAULT • Printer.PARAM_UNSPECIFIED
addCut	type	<ul style="list-style-type: none"> • Printer.CUT_FEED • Printer.CUT_NO_FEED • Printer.PARAM_DEFAULT

Usage restriction by firmware version

Availability and restriction on the use of APIs and parameters depends on the versions of the firmware and software installed on the printer. For how to check the versions and/or update the firmware and software, refer to the Technical Reference Guide of the printer.

TM-i Series/TM-DT Series

❑ Supported by TM-DT software Ver. 2.5 and TM-i firmware 4.0 or later.

Class	API	Parameter	Value
CommBox class	-	-	-

❑ Supported by TM-DT software Ver. 2.5 and TM-i firmware 4.1 or later.

Class	API	Parameter	Value
Printer class	requestPrintJobStatus	-	-
	addSymbol	data	QR Code Micro
	addSymbol	type	Printer.SymbolType.QRCodeMicro
	setReceiveEventListener	args	PrintJobId

❑ Supported by TM-DT software Ver. 3.02 and TM-i firmware 4.4 or later.

Class	API	Parameter	Value
Discovery class	-	-	-

❑ Supported by TM-DT software Ver. 4.0 or later.

Class	API	Parameter	Value
POSKeyboard class	-	-	-
MSR class	-	-	-
OtherPeripheral class	-	-	-
Discovery class	start	deviceType	Discovery.TYPE_POS_KEYBOARD
			Discovery.TYPE_MSR
			Discovery.TYPE_OTHER_PERIPHERAL

TM-m30

❑ Supported by TM-m30 firmware Ver. 1.40 ESC/POS or later.

Class	API	Parameter	Value
BarcodeScanner class	-	-	-

❑ Supported with the following versions of firmware.

- TM-m30 firmware Ver. 1.46A ESC/POS or later
- TM-m30 firmware Ver. 1.46B ESC/POS or later

Class	API	Parameter	Value
GermanyFiscalElement class	-	-	-

TM-T88VI

❑ Supported by TM-T88VI firmware Ver. 40.50 ESC/POS or later.

Class	API	Parameter	Value
BarcodeScanner class	-	-	-

TM-T88VI-iHUB

❑ Supported with the following versions of firmware.

- TM-T88VI-iHUB firmware Ver. 50.52A ESC/POS or later
- TM-T88VI-iHUB firmware Ver. 50.52B ESC/POS or later

Class	API	Parameter	Value
GermanyFiscalElement class	-	-	-

Sample Programs

The sample programs provided with Epson ePOS SDK for Android are implementation samples of Android applications.

Android Studio Android application projects that include the Java source files are provided.



The provided sample programs were created with sample API Level 14.

Functionality

The sample programs provide the following functionality.

ePOS2Printer

- Printer search and specification
 - Specifies the connection type.
 - Displays a list of search results.
 - Retrieves target information required for the connection selected from the search results.
- Sample receipt printing
- Sample coupon printing
- Printer status confirmation
 - Confirms the status of printers before printing.
 - When the printer is not capable of printing, the program generates a notification message of the possible causes and corresponding action of the error.
- Display of print results and printer status
 - Sends notification of the print result after printing.
 - The program generates a message corresponding to the printer status at the time that the printer result notification was made.
 - Notifies the users of an API error that occurred while searching for printers, or during printing sample receipts or coupons.
- Log Output Settings
 - Enables log output to terminal storage when displaying the main screen.

ePOS2 Hybrid Printer

- Printer search and specification
 - Displays a list of search results.
 - Retrieves target information required for the connection selected from the search results.
- Controls operations continuously from endorsement printing after MICR reading to slip and receipt printings.
- Validation printing
- Printer status confirmation
 - Confirms the status of printers before printing.
 - When the printer is not capable of printing, the program generates a notification message of the possible causes and corresponding action of the error.
- Display of print results and printer status
 - Sends notification of the print result after printing.
 - The program generates a message corresponding to the printer status at the time that the printer result notification was made.
 - Notifies the users of an API error that occurred while searching for printers or printing samples.
- Sets the log output function.
 - Enables log output to terminal storage when displaying the main screen.

ePOS2Discovery

- Filter Option settings
- Search of printers and peripheral devices
- Search initiation
- Display of search results
- Search completion
- Error notification
 - Notifies the users of an API error that occurred when starting a search, during searching, or in the process of completing a search.

ePOS2LineDisplay

- Display of the specified text on the customer display
- Turns on or off the blinking display
- Error notification
 - When failed to connect to the customer display, notifies the user of the connection error.
 - Notifies the users of an API error that occurred while sending display data to the customer display.

ePOS2Keyboard

- Starts and ends connection with the printer
 - Connects to the specified keyboard.
 - When failed to connect to the keyboard, notifies the user of the connection error.
- Display of text input with the keyboard in text boxes in the application
- Error notification
 - Notifies the users of an API error that occurred while entering text with the keyboard.

ePOS2POSKeyboard

- Starts and ends connection with TM-DT
 - Connects to the specified keyboard.
 - When failed to connect to the keyboard, notifies the user of the connection error.
- Display of keycode input with the keyboard in text boxes in the application
- Error notification
 - Notifies the users of an API error that occurred while entering keycode with the keyboard.

ePOS2BarcodeScanner

- Starts and ends connection with the printer
 - Connects to a barcode scanner specified.
 - When failed to connect to the barcode scanner, notifies the user of the connection error.
- Display of data read by the barcode scanner in text boxes in the application
- Error notification
 - Notifies the users of an API error that occurred while reading data with the barcode scanner.

ePOS2MSR

- Starts and ends connection with TM-DT
 - Starts connection with the MSR specified in the Target text boxes.
 - Ends connection with the connected MSR.
- Display of data read by the MSR in text boxes in the application
- Error notification
 - Notifies the users of an API error that occurred while reading data with the MSR.

ePOS2SimpleSerial

- Starts and ends connection with the printer
 - Connects to the specified serial communication device.
 - When failed to connect to the serial communication device, notifies the user of the connection error.
- Transmission of data specified by the application to the serial communication device.
- Display of response commands from the serial communication device in the application
- Error notification
 - Notifies the users of an API error that occurred while sending data to the serial communication device.

ePOS2GermanyFiscalElement

- Peripheral device settings
 - Searches for the printer, and displays the search results in a list.
 - Specifies the printer to be used.
 - Specifies the German fiscal element (TSE) to be used.
 - Specifies the customer display to be used.
 - Sets up German fiscal element (TSE) to be used.
- Purchase of a product
 - A product is selected by pushing a button.
 - The barcode is read by the barcode scanner, and the product is selected.
 - Displays the price of the selected product on the customer display.
 - Writes the information of the selected product to German fiscal element (TSE).
- Payment for a product
 - Displays the total price of the products on the customer display.
 - Prints the receipt.
 - Writes the information of the product for which payment is finished to German fiscal element (TSE).
- Export from German fiscal element (TSE)
 - Exports the information written to German fiscal element (TSE).
- Information acquisition from German fiscal element (TSE)
 - Acquires the information of German fiscal element (TSE).
- Printer firmware update
 - Acquires the firmware version of the connected printer.
 - Acquires the released version of printer firmware.
 - Updates the printer firmware.

ePOS2OtherPeripheral

- Starts and ends connection with TM-DT
 - Starts connection with the device specified in the Target text boxes.
 - Ends connection with connected device.
- Transmission of JSON data specified by the application to the device
- Display of response commands from the device in the text boxes
- Error notification
 - Notifies the users of an API error that occurred at the timing when the process was run by the device.

ePOS2CommBox

- Starts and ends connection with the printer
 - Connects to the communication box specified.
 - When failed to connect to the communication box, notifies the user of the connection error.
- Transmission of messages to the member ID specified by the application
- Error notification
 - Notifies the users of an API error that occurred when sending a message.

ePOS2EasySelection

- Easy connection with a printer by using its NFC tag or QR code.
 - Acquires printer information from the NFC tag.
 - Acquires printer information from the QR code.
 - Opens the port by using the acquired printer information.
- Printing of a QR code that enables easy printer selection.
 - Creates a QR code that contains the printer information from the printer search result.

Use Environment

Refer to [Epson ePOS SDK for Android Development Environment](#) and [Application Operating Environment](#).

Installation Procedure

- 1 Extract the sample programs from the zip file and store the extracted files at any desired location.
- 2 Start Android Studio and click **Open an existing Android Studio Project**.

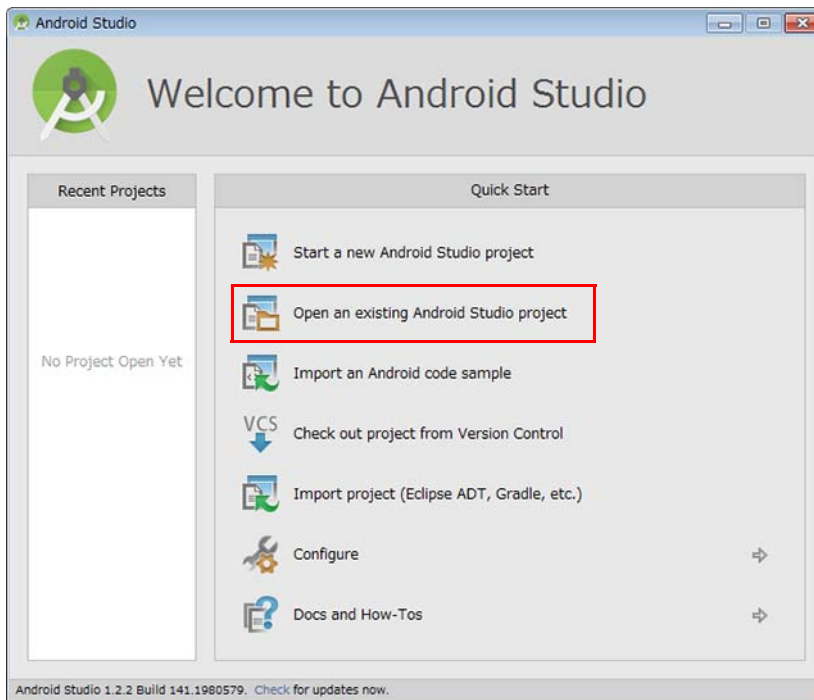

- 3** Select a sample program you want to install from the sample programs you stored at step 1, and then click **OK**.

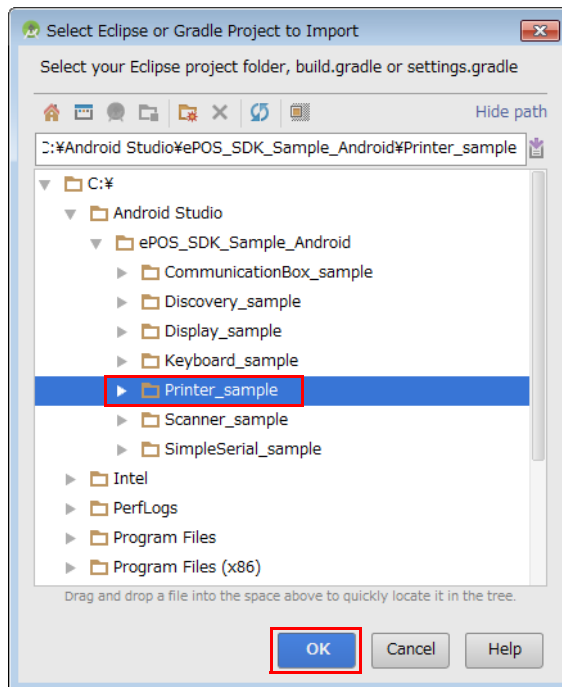

- 4** Click the **Run app** button.

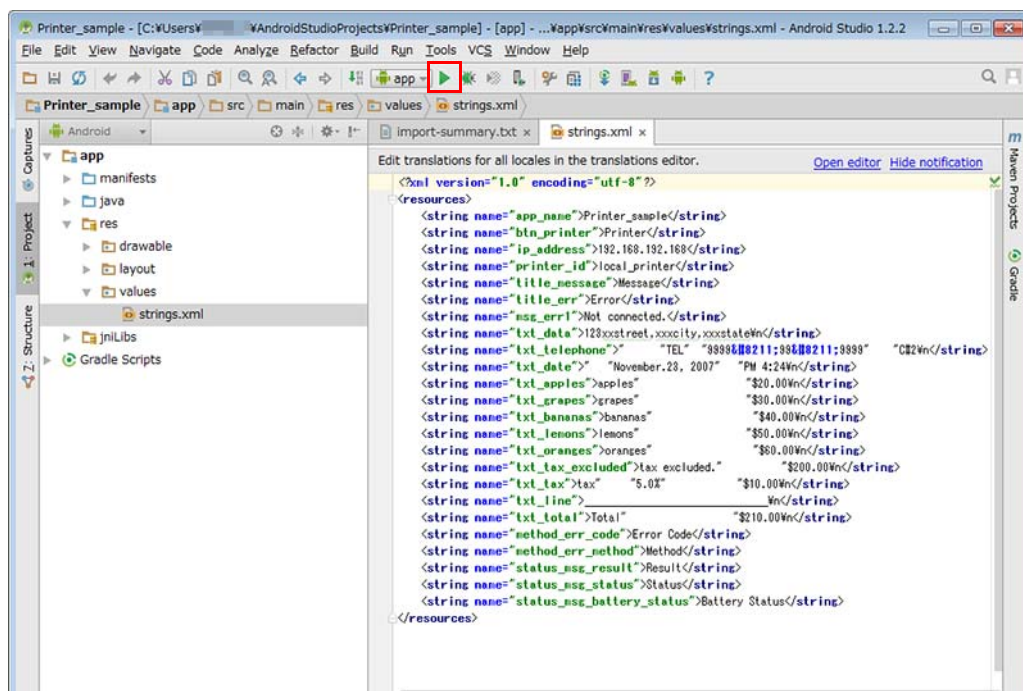

5 Select the device and then click **OK**.

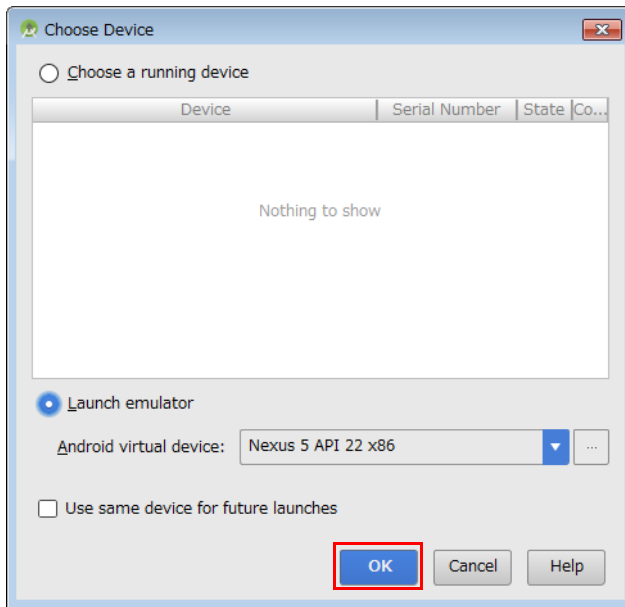

Application Guide

To connect via USB

For a USB interface, we recommend obtaining access permission to USB devices in the application software.



To open a port using the connect without obtaining access permission to USB devices in advance, note the following:

- When [OK] is pressed in the dialog box for access permission acquisition, it takes about 10 seconds to open a port.
- When [Cancel] is pressed in the dialog box for access permission acquisition, the state of waiting for the timeout lasts for 30 seconds.

How to obtain access permission in the application software is as follows:

1 Add the following code to AndroidManifest.xml.

```
<manifest ...>
  <application>
    <activity ...>
      <intent-filter>
        <action android:name="android.hardware.usb.action.USB_DEVICE_ATTACHED" />
      </intent-filter>
      <meta-data android:name="android.hardware.usb.action.USB_DEVICE_ATTACHED"
        android:resource="@xml/device_filter" />
    </activity>
  </application>
</manifest>
```

2 Add res/xml/device_filter.xml to the source file.

3 Write the following code in the device_filter.xml file.

```
<?xml version="1.0" encoding="utf-8"?>
<resources>
  <usb-device vendor-id="1208" />
</resources>
```

4 A dialog box appears when obtaining access permission. Press [OK].

To search printers

```

Starts searching
FilterOption filterOption = null;
filterOption = new FilterOption();

//Specifies the port to search
filterOption.PortType = Discovery.SOCKET_ALL;

//Specifies the Broadcast address.
filterOption.broadcast = "255.255.255.255";

//Specifies the device model to search.
filterOption.deviceModel = Discovery.MODEL_ALL;

//Specifies the device type to search.
filterOption.deviceType = Discovery.TYPE_ALL;

Starts searching
try {
    Discovery.start(mContext, filterOption, mDiscoveryListener);
}
catch (Exception e) {
    //Displays error messages
}

Notifies the detected devices
private DiscoveryListener mDiscoveryListener = new DiscoveryListener() {
    @Override
    public void onDiscovery(final DeviceInfo deviceInfo) {
        runOnUiThread(new Runnable() {
            @Override
            public synchronized void run() {
                //Display the detected device in the application software
            }
        });
    }
};

Stops searching
private void stopDiscovery() {
    try {
        Discovery.stop();
    }
    catch (Epos2Exception e) {
        //Displays error messages
    }
}

```

To monitor continuously

When application starts

```
Printer printer = null;

try {
    printer = new Printer(printer.TM_T88, printer.MODEL_ANK, this);
}
catch (Exception e) {
    //Displays error messages
}

printer.setStatusChangeListener(this);

try {
    printer.connect("TCP:192.168.192.168", printer.PARAM_DEFAULT);
}
catch (Exception e) {
    //Displays error messages
}

try {
    printer.setInterval(3000);
    printer.startMonitor();
}
catch (Exception e) {
    //Displays error messages
}
```

Repeats

```
//Buffers the print data(addText..)
//Sends the print data (sendData)
```

When application closes

```
try {
    printer.stopMonitor();
}
catch (Exception e) {
    //Displays error messages
}
try {
    printer.disconnect();
}
catch (Exception e) {
    //Displays error messages
}
```

```

public void onPtrStatusChange(Printer printerObj, final int eventType) {
    runOnUiThread(new Runnable() {
        @Override
        public synchronized void run() {
            switch (eventType) {
                case Printer.EVENT_ONLINE:
                    break;
                case Printer.EVENT_OFFLINE:
                    //Displays notification messages
                    break;
                case Printer.EVENT_POWER_OFF:
                    //Displays notification messages
                    break;
                case Printer.EVENT_COVER_CLOSE:
                    //Displays notification messages
                    break;
                case Printer.EVENT_COVER_OPEN:
                    //Displays notification messages
                    break;
                case Printer.EVENT_PAPER_OK:
                    //Displays notification messages
                    break;
                case Printer.EVENT_PAPER_NEAR_END:
                    //Displays notification messages
                    break;
                case Printer.EVENT_PAPER_EMPTY:
                    //Displays notification messages
                    break;
                case Printer.EVENT_DRAWER_HIGH:
                    //Displays notification messages
                    break;
                case Printer.EVENT_DRAWER_LOW:
                    //Displays notification messages
                    break;
                case Printer.EVENT_BATTERY_ENOUGH:
                    //Displays notification messages
                    break;
                case Printer.EVENT_BATTERY_EMPTY:
                    //Displays notification messages
                    break;
                default:
                    break;
            }
        }
    });
}

```



Refer to [Error Status and countermeasures](#) for the messages displayed on "Displays notification messages".

To use the same printer from multiple mobile devices

The following shows a processing flow when using a single printer from the mobile terminal A and B.

 The diagram below shows the process flow for controlling a TM printer.

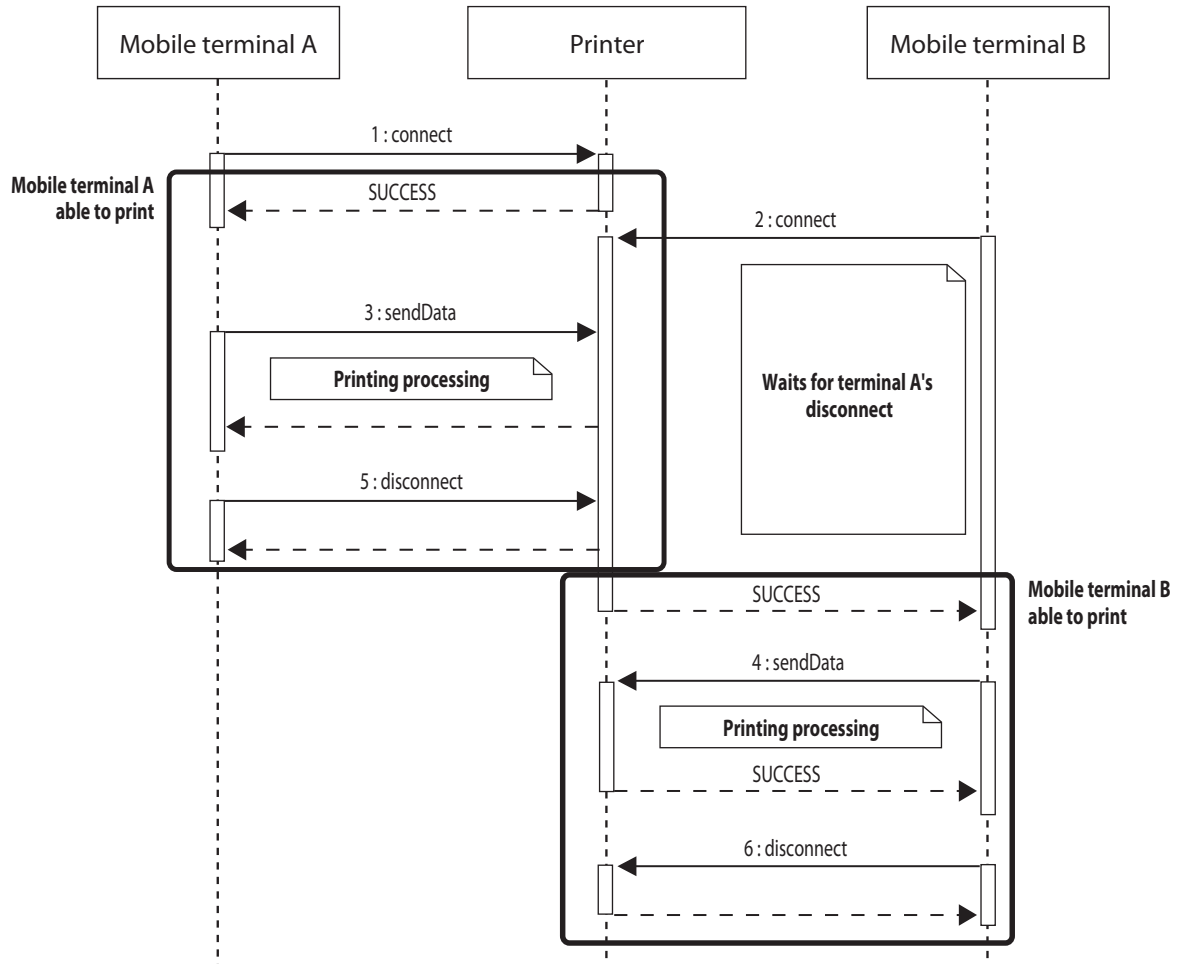

To specify a transaction

Put the set of print processing to be carried out consecutively (such as a single receipt or a single coupon) between `beginTransaction` and `endTransaction`.

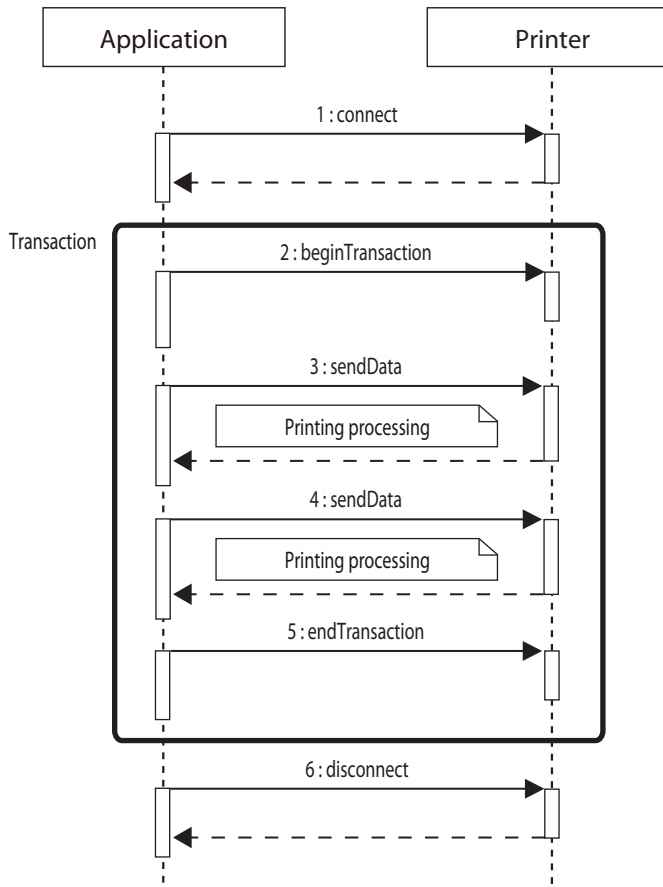

To reconnect to the network automatically

The following is a sequence for automatically reconnecting if network communication is cut off with the printer.

The following uses a case where the barcode scanner is used as an example.

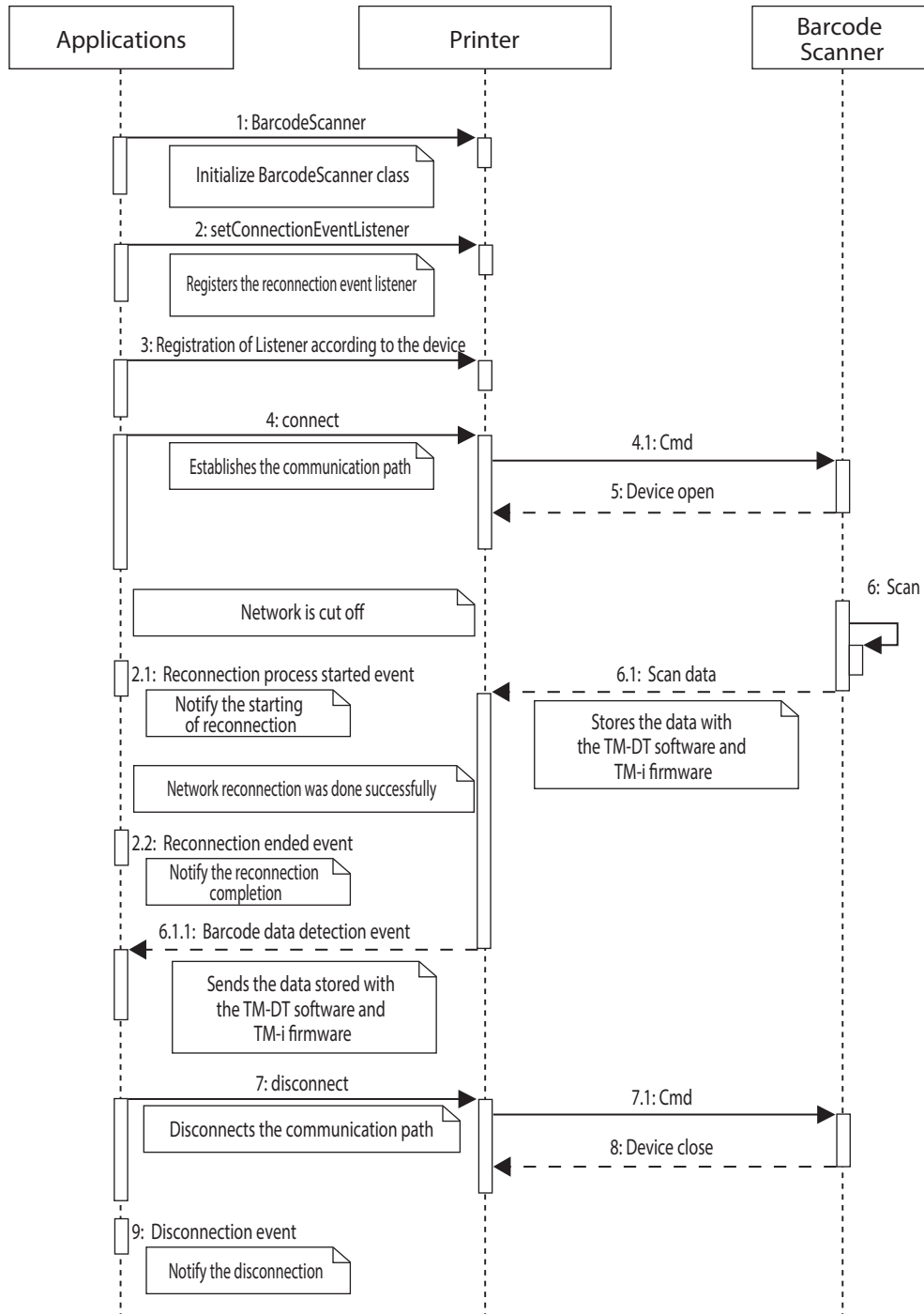

To transmit and receive the data between applications

Use the Communication Box function of the printer.

For details on a printer equipped with the Communication Box function, refer to [Functions provided in each printer](#).

The following indicates the basic programming sequence using the Communication Box. A "Client" in the sequence figure refers to an application.

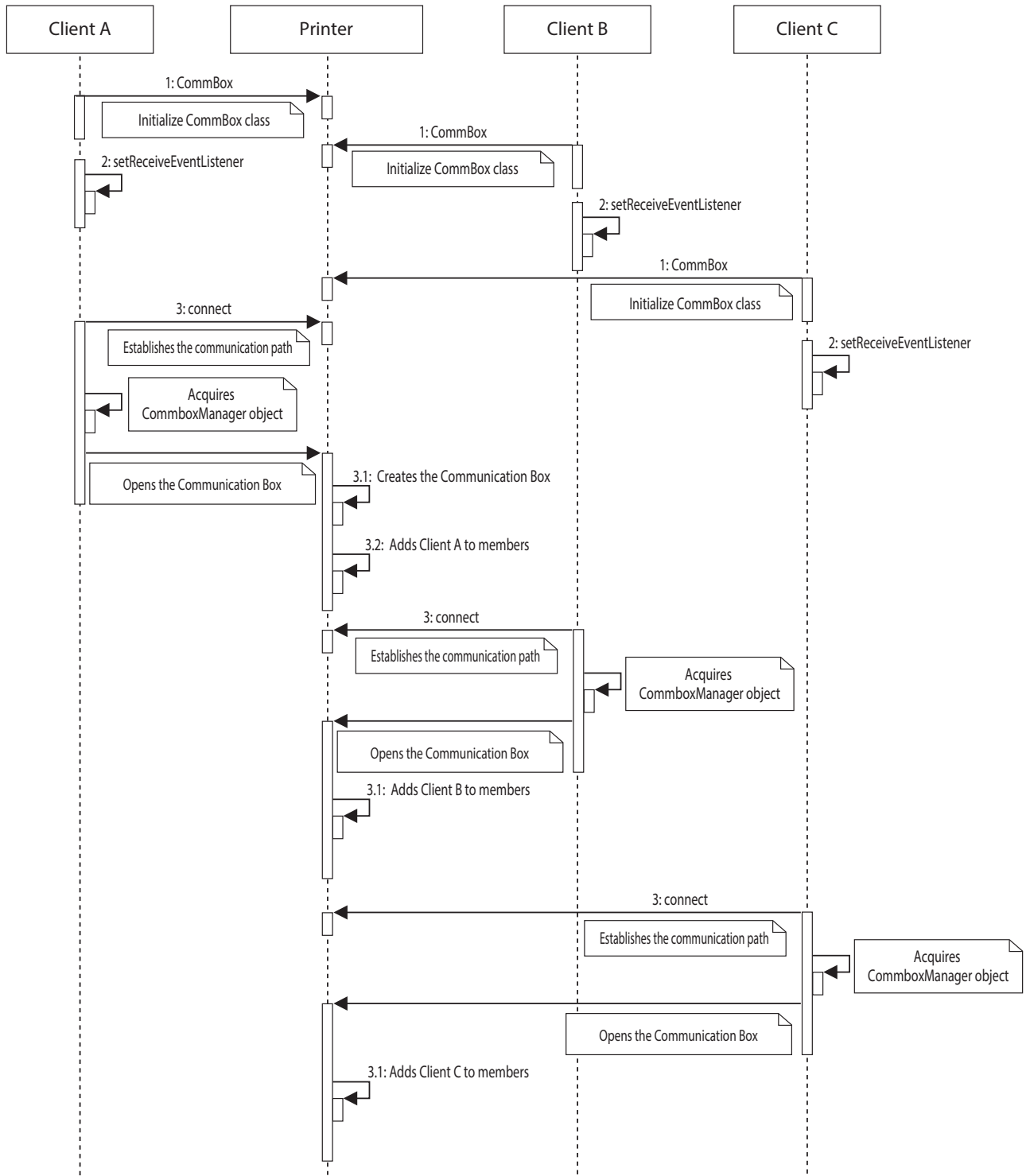

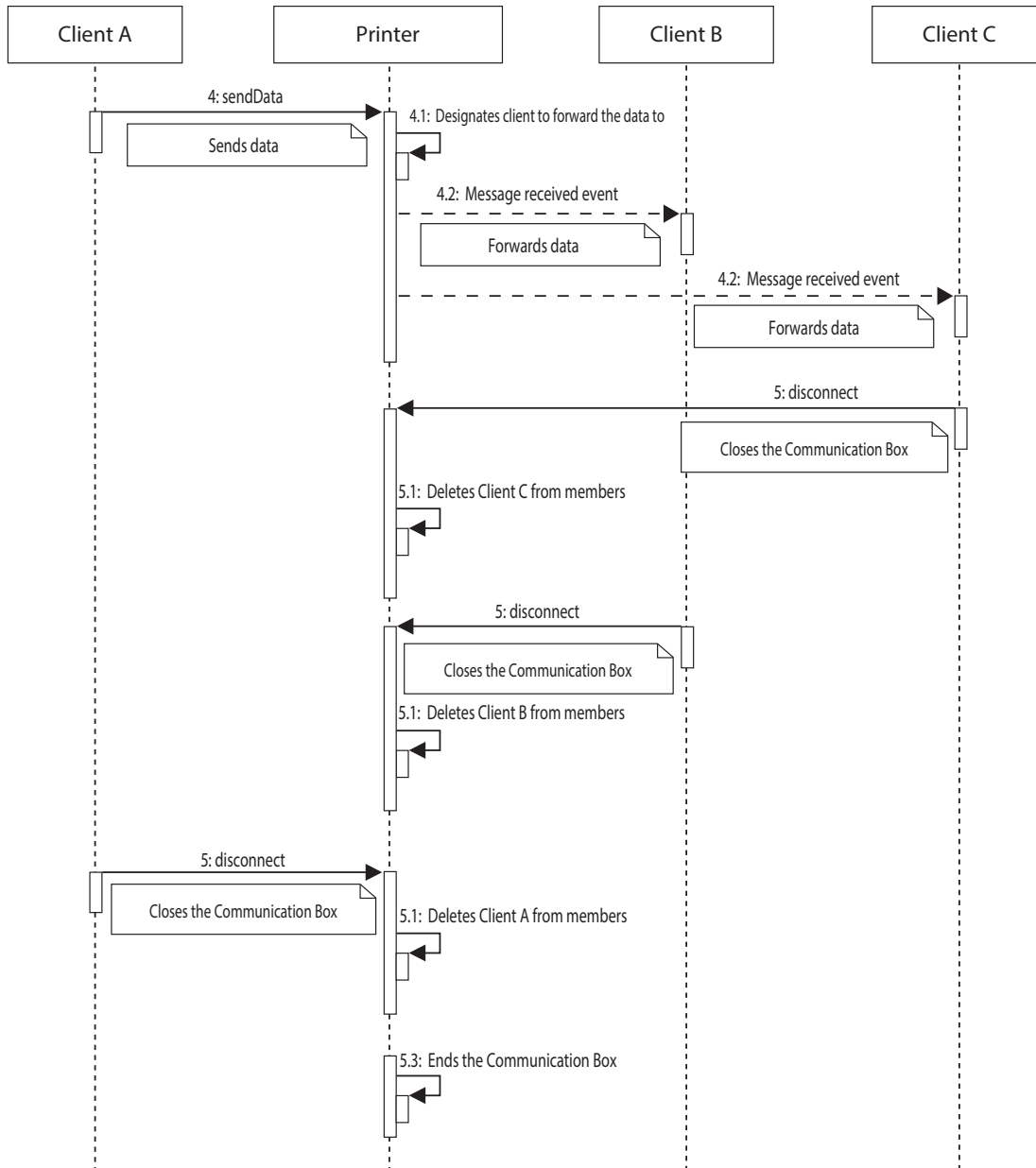

To perform forward printing

Use the spooler function of printers.

For details on a printer equipped with the spooler function, refer to [Functions provided in each printer](#).

If a request is sent to the printer equipped with the spooler function from the application when the spooler function is disabled, printing is immediately executed and a response is returned to the application after printing completes.

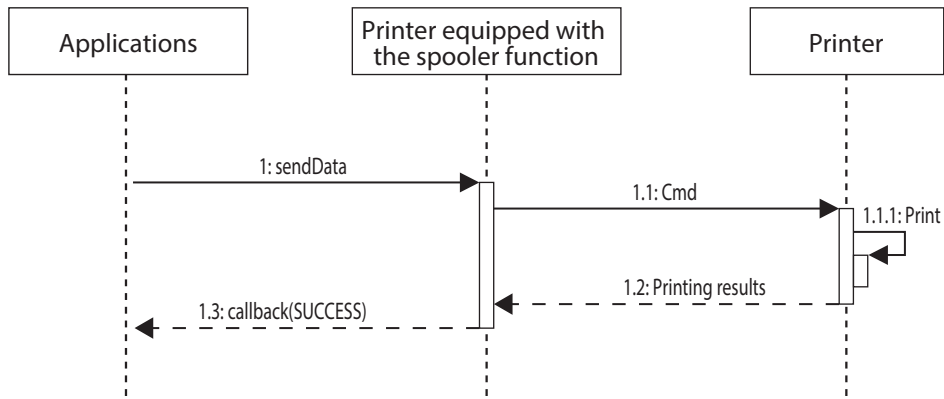

If a request is sent to the printer equipped with the spooler function from the application when the spooler function is enabled, the print job is stored in the print queue and a response is returned to the application before printing completes.

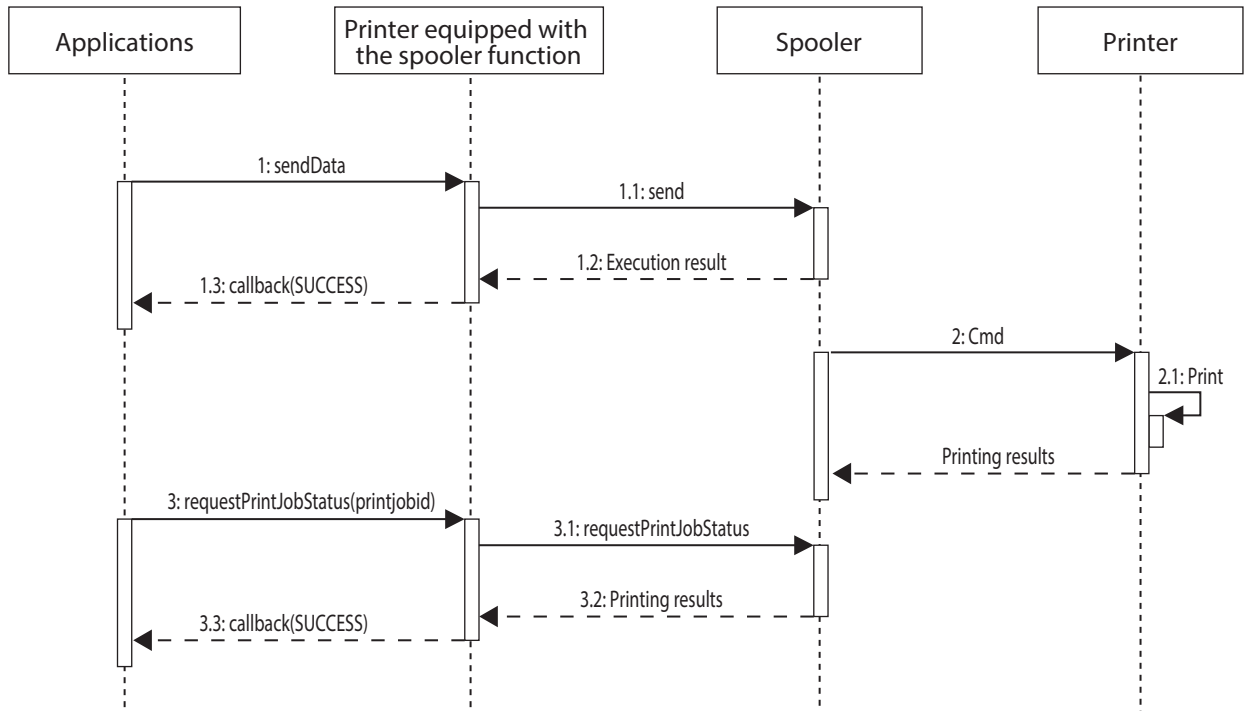

If the destination printer cannot print, the printer equipped with the spooler function does not return the error to the application. Enabling forward printing will allow for the printing task to be completed on a substitute printer, with the application acquiring the printing results afterward. Refer to the sequence diagram below.

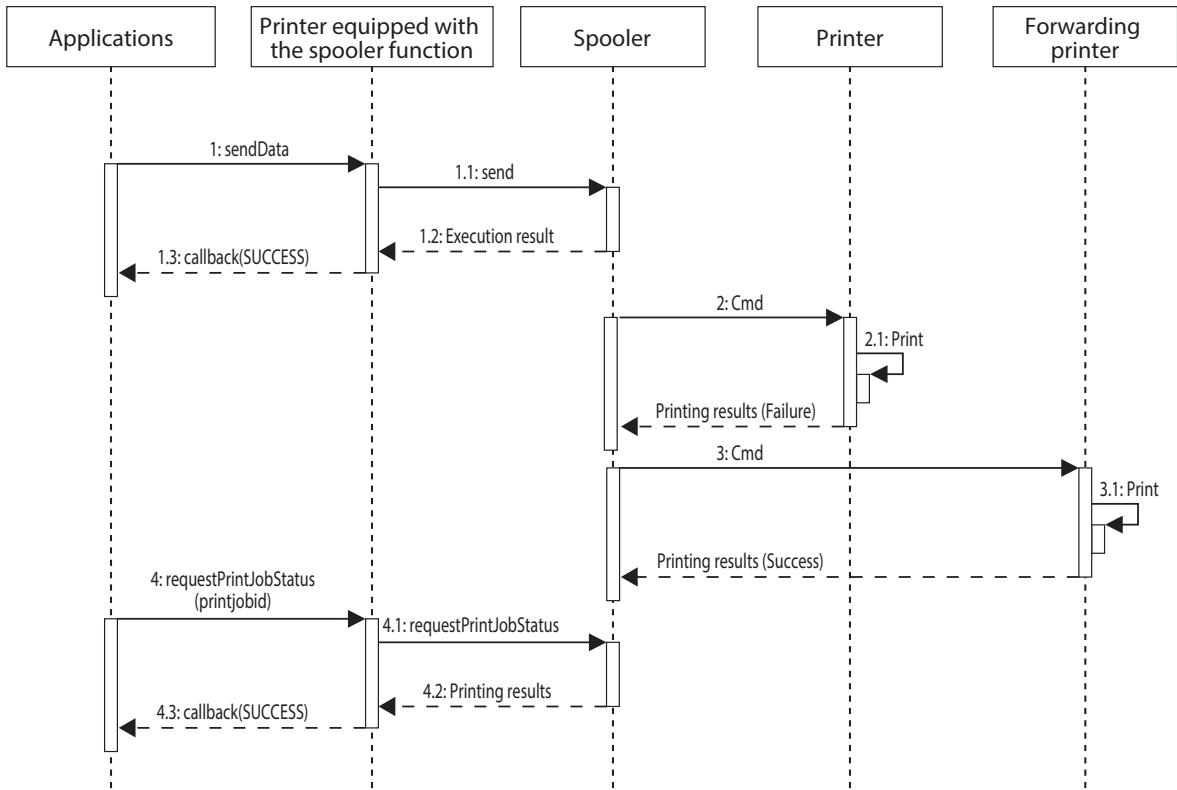

To select a printer using its NFC tag

Analyze the NFC tag by using `parseNFC` in the `EasySelect` class. Then, specify the analyzed information in the connect API to connect to the printer.

```

Printer printer;

@Override
protected void onNewIntent(Intent intent) {

    //Receives NFC tag by onNewIntent

    EasySelect easySelect = new EasySelect();

    Tag tag = (Tag)intent.getParcelableExtra( NfcAdapter.EXTRA_TAG );

    //Analyses the NFC tag
    ArrayList<EasySelectInfo> easySelectInfoArray = null;
    easySelectInfoArray = easySelect.parseNFC( tag, PARSE_NFC_TIMEOUT_DEFAULT );
    if ((null == easySelectInfoArray) || (easySelectInfoArray.size() == 0)){
        // If the NFC tag is not the one for easy printer selection
        return ;
    }

    //Acquires the first data of the NFC
    EasySelectInfo easySelectInfo = easySelectInfoArray.get(0);

    String printerName = easySelectInfo.printerName;
    if(printerName == null || printerName.equals("")){
        printerName = "TM-T88V"; //Name of the target printer
    }

    // Converts the printer name into PrinterSeries
    int printerSeries = convertPrinterNameToPrinterSeries(printerName);

    String macAddress = easySelectInfo.macAddress;
    if(macAddress == null || macAddress.equals("")){
        //When failed to acquire macAddress
    }

    try {
        // Initializes the Printer
        printer = new Printer(printerSeries, Printer.MODEL_ANK, getApplicationContext());

        // Generates connect parameters
        String targetText = convertEasySelectInfoToTargetString(easySelectInfo);

        // Connects to the printer
        printer.connect(targetText, Printer.PARAM_DEFAULT);

        // Exception processing
    } catch (Epos2Exception e) {
        // Write exception processing
    }
}

```



```

private int convertPrinterNameToPrinterSeries(String printerName) {

    int printerSeries = Printer.TM_T88;

    if(printerName.equals("TM-T88V")){
        printerSeries = Printer.TM_T88;
    }else if(printerName.equals("TM-m10")){
        printerSeries = Printer.TM_M10;
    }else if(printerName.equals("TM-m30")){
        printerSeries = Printer.TM_M30;
    }else if(printerName.equals("TM-P20")){
        printerSeries = Printer.TM_P20;
    }else if(printerName.equals("TM-P60II")){
        printerSeries = Printer.TM_P60II;
    }else if(printerName.equals("TM-P80")){
        printerSeries = Printer.TM_P80;
    }else{
        // Depending on the printer, add conversion processes
    }

    return printerSeries;
}

private String convertEasySelectInfoToTargetString(EasySelectInfo easySelectInfo) {

    StringBuffer sb = new StringBuffer();

    switch(easySelectInfo.deviceType){
        case EasySelectDeviceType.TCP:
            sb.append("TCP:");
            break;
        case EasySelectDeviceType.BLUETOOTH:
            sb.append("BT:");
            break;
    }
    sb.append(easySelectInfo.macAddress);
    return sb.toString();
}

```



This function is available only with NFC-compatible printers.

To select a printer using its QR code

Analyze the QR code by using parseQR in the EasySelect class. Then, specify the analyzed information in the connect API to connect to the printer.

```

EasySelect easySelect = new EasySelect();
String data;
Printer printer;

public void ConnectPrinterByQRCode() {

    // Stores QR code data acquired from the scanned image

    //Analyzes the QR code
    EasySelectInfo easySelectInfo = easySelect.parseQR(data);
    if (null == easySelectInfo) {
        // If the QR code is not the one for easy printer selection
        return ;
    }

    // Converts the printer name into PrinterSeries
    int printerSeries = convertPrinterNameToPrinterSeries(easySelectInfo.printerName);

    try {
        // Initializes the Printer
        printer = new Printer(printerSeries, Printer.MODEL_ANK, getApplicationContext());

        // Generates connect parameters
        String targetText = convertEasySelectInfoToTargetString(easySelectInfo);

        // Connects to the printer
        printer.connect(targetText, Printer.PARAM_DEFAULT);

        // Exception processing
    } catch (Epos2Exception e) {
        // Write exception processing
    }
}

private int convertPrinterNameToPrinterSeries(String printerName) {

    int printerSeries = Printer.TM_T88;

    if(printerName.equals("TM-T88V")){
        printerSeries = Printer.TM_T88;
    }else if(printerName.equals("TM-m10")){
        printerSeries = Printer.TM_M10;
    }else if(printerName.equals("TM-m30")){
        printerSeries = Printer.TM_M30;
    }else if(printerName.equals("TM-P20")){
        printerSeries = Printer.TM_P20;
    }else if(printerName.equals("TM-P60II")){
        printerSeries = Printer.TM_P60II;
    }else if(printerName.equals("TM-P80")){
        printerSeries = Printer.TM_P80;
    }else{
        // Depending on the printer, add conversion processes
    }

    return printerSeries;
}

```

```
private String convertEasySelectInfoToTargetString(EasySelectInfo easySelectInfo) {  
    StringBuffer sb = new StringBuffer();  
  
    switch(easySelectInfo.deviceType){  
        case EasySelectDeviceType.TCP:  
            sb.append("TCP:");  
            break;  
        case EasySelectDeviceType.BLUETOOTH:  
            sb.append("BT:");  
            break;  
    }  
    sb.append(easySelectInfo.macAddress);  
    return sb.toString();  
}
```

How to print a QR code to be used for printer selection

For the printers that can print the QR code on a status sheet

Some printers can print the QR code on a status sheet. For more details, refer to the Technical Reference Guide of the printer.

For the printers that cannot print the QR code on a status sheet

Create the QR code by using createQR. Specify the created data by addSymbol to print the QR code. Refer to "Creating QR code" in the Sample Programs.

To perform check process

HybridPrinter class is used to control the hybrid model printers.

The following sequence diagram shows the flow from endorsement printing after MICR reading to slip printing.

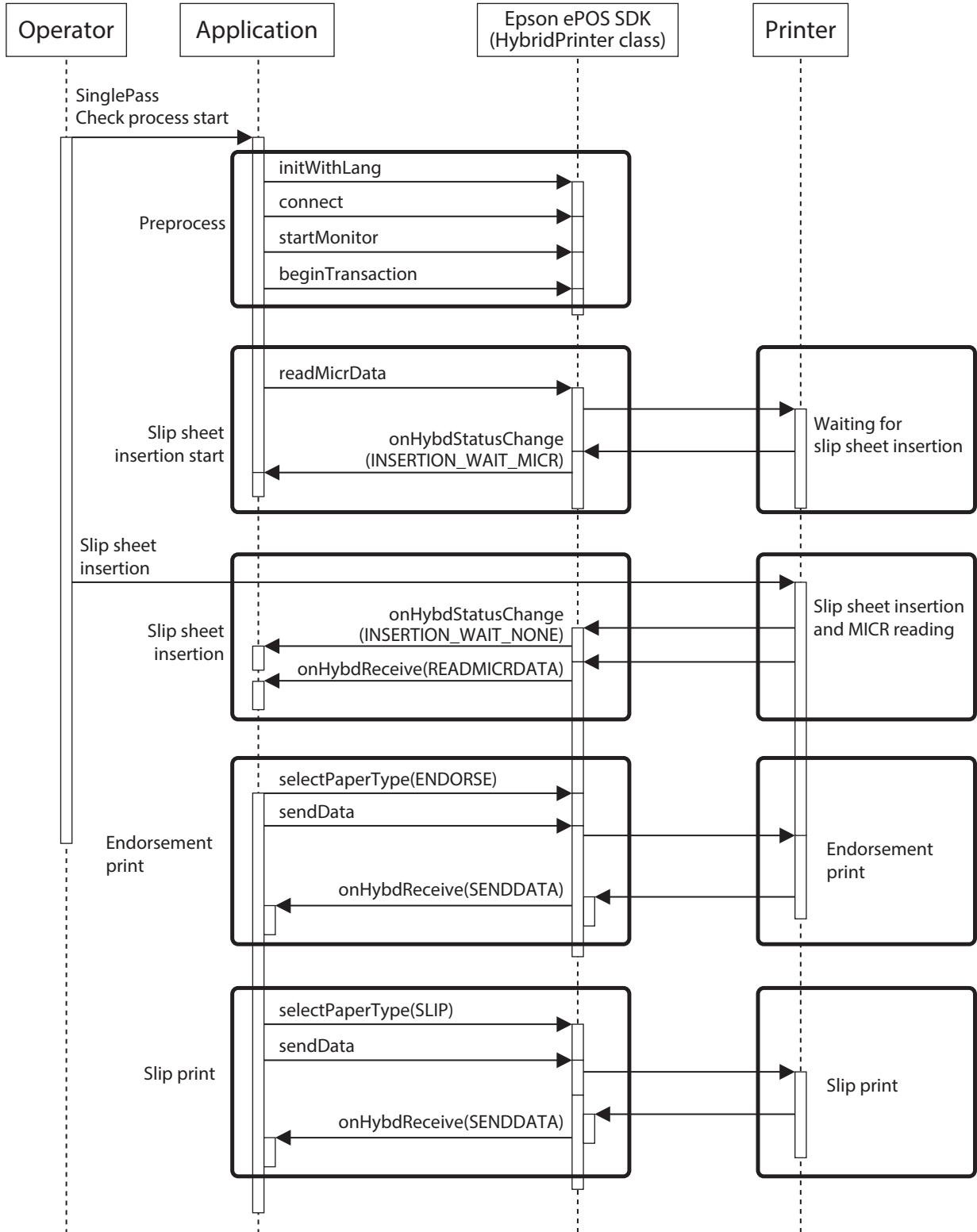

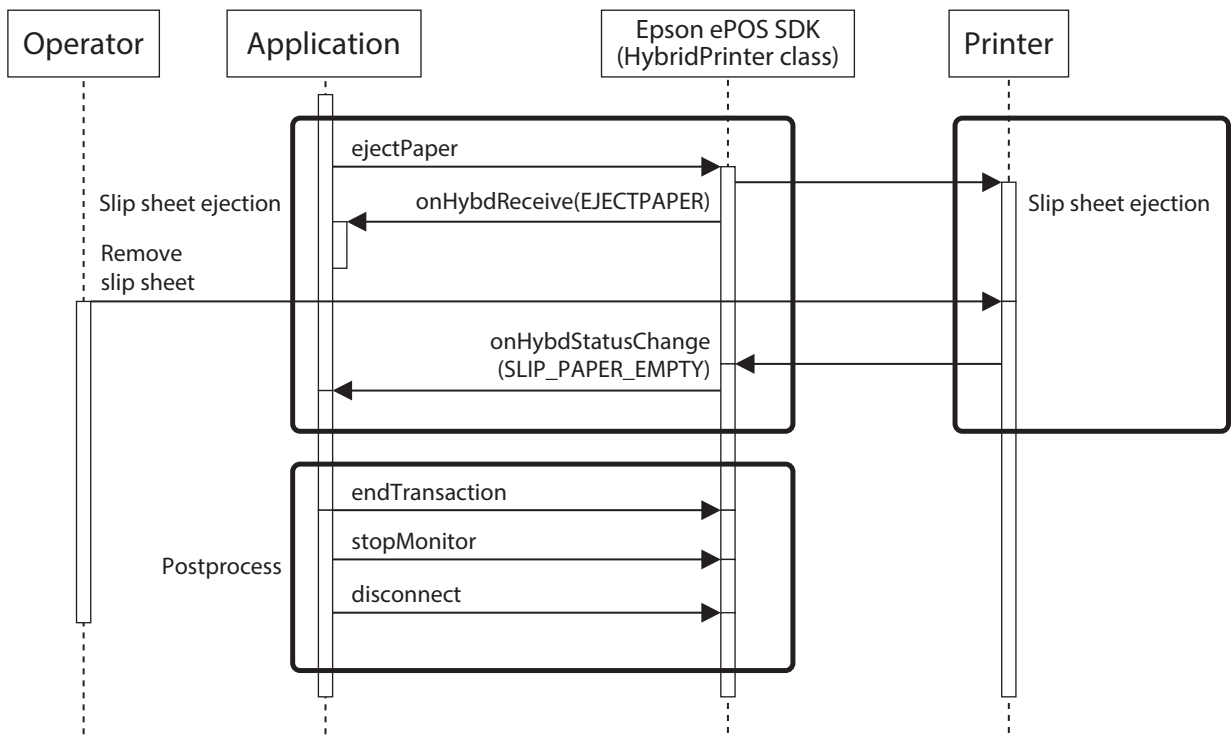

To control multiple peripheral devices

The sequence diagram that controls the printer and customer display is indicated below.

-  To connect/disconnect communication with the printer or peripheral devices, call connect API/disconnect API from one thread to each peripheral device in order.
- The following process can be processed concurrently in one thread.
 - * Displaying data on the customer display
 - * Receipt printing

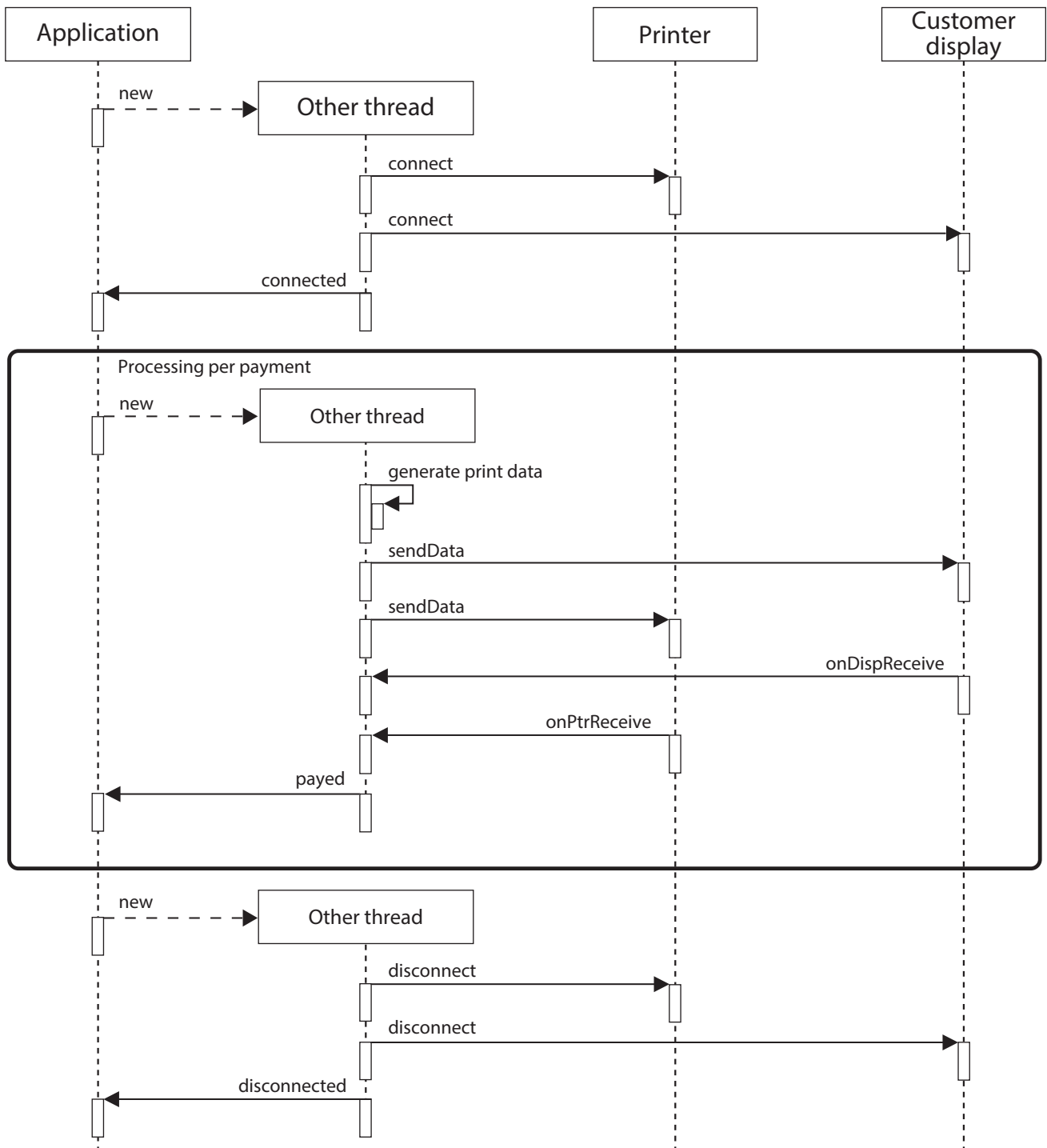

To control multiple peripheral devices

The sequence diagram that controls the printer and customer display is indicated below.

-  To connect/disconnect communication with the printer or peripheral devices, call connect API/disconnect API from one thread to each peripheral device in order.
- The following process can be processed concurrently in one thread.
 - * Displaying data on the customer display
 - * Receipt printing

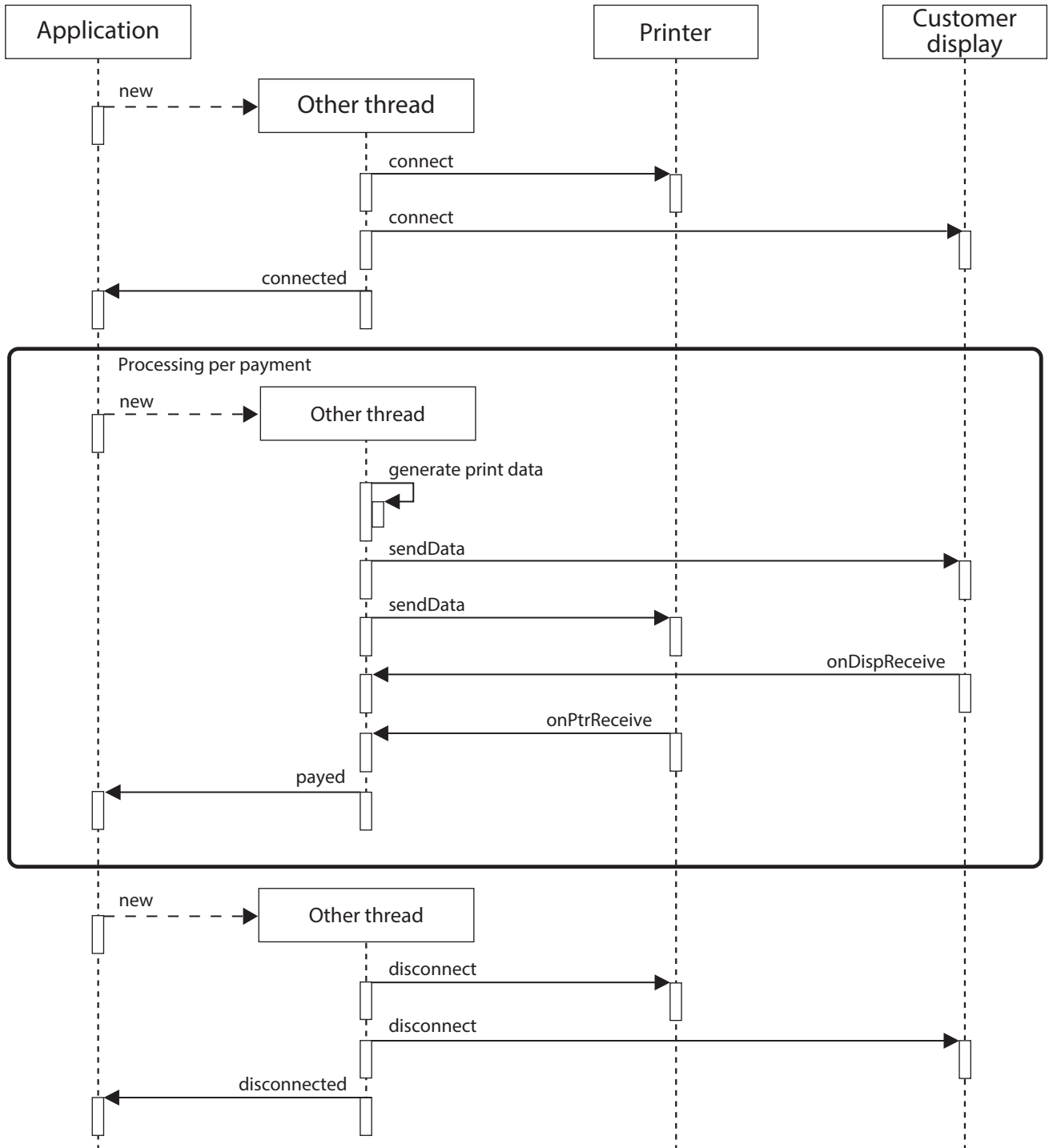

To update the printer firmware version

Use the following APIs in the Printer class:

- [downloadFirmwareList](#)
- [updateFirmware](#)
- [verifyUpdate](#)

The sequence diagram of firmware version update is shown below.

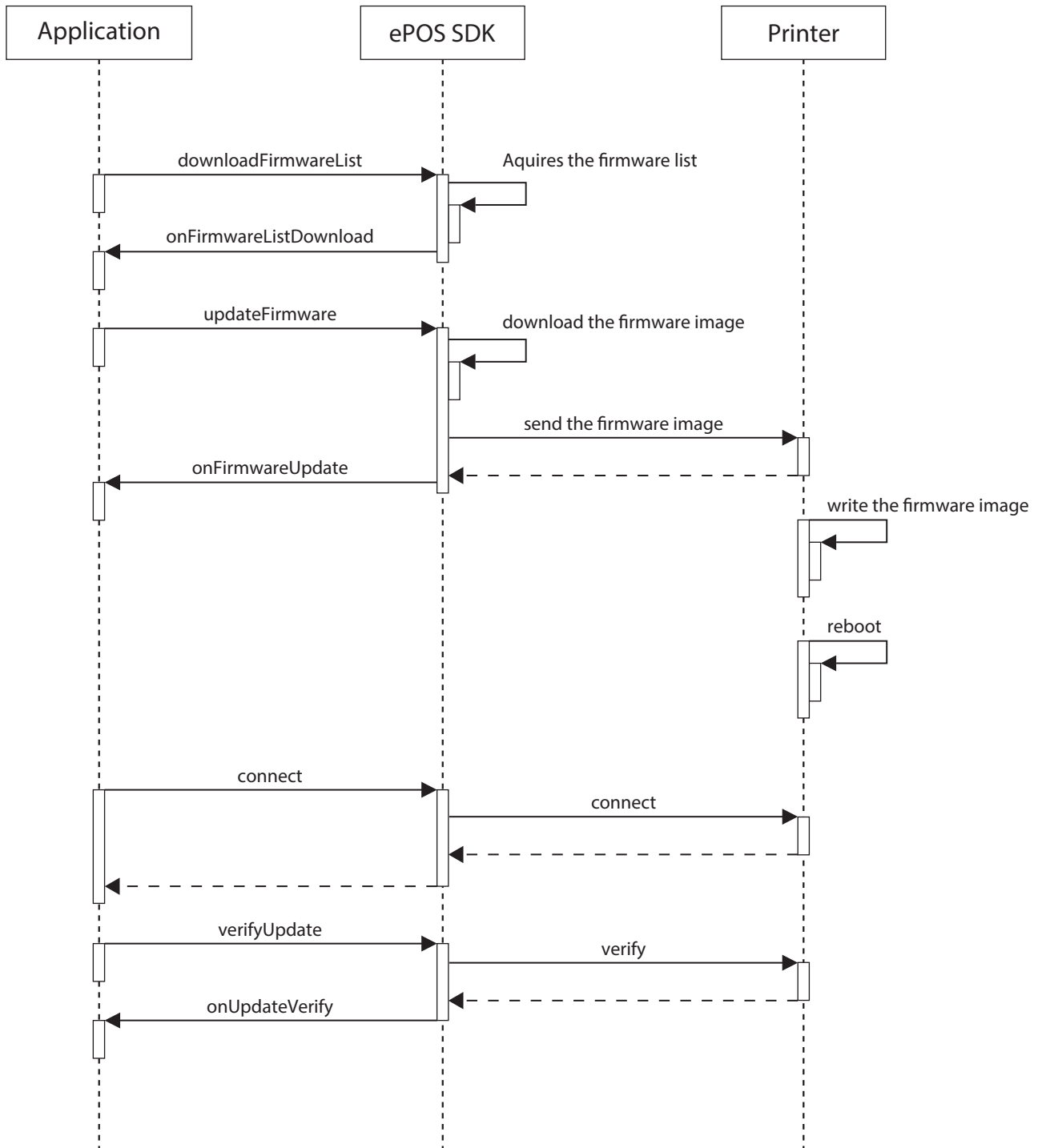

Appendix

Open Source Software Licensing

The following open-source software is used in the sample programs and libraries provided by the Epson ePOS SDK for Android.

Sample Programs

ZXing(<https://github.com/zxing/zxing>)

ZXing is licensed based on Apache 2.0 license (<http://www.apache.org/licenses/LICENSE-2.0.html>).

libraries

libxml2

Except where otherwise noted in the source code (e.g. the files hash.c, list.c and the trio files, which are covered by a similar license but with different Copyright notices) all the files are:

Copyright (C) 1998-2003 Daniel Veillard. All Rights Reserved.

Permission is hereby granted, free of charge, to any person obtaining a copy of this software and associated documentation files (the "Software"), to deal in the Software without restriction, including without limitation the rights to use, copy, modify, merge, publish, distribute, sublicense, and/or sell copies of the Software, and to permit persons to whom the Software is furnished to do so, subject to the following conditions:

The above copyright notice and this permission notice shall be included in all copies or substantial portions of the Software.

THE SOFTWARE IS PROVIDED "AS IS", WITHOUT WARRANTY OF ANY KIND, EXPRESS OR IMPLIED, INCLUDING BUT NOT LIMITED TO THE WARRANTIES OF MERCHANTABILITY, FITNESS FOR A PARTICULAR PURPOSE AND NONINFRINGEMENT. IN NO EVENT SHALL THE DANIEL VEILLARD BE LIABLE FOR ANY CLAIM, DAMAGES OR OTHER LIABILITY, WHETHER IN AN ACTION OF CONTRACT, TORT OR OTHERWISE, ARISING FROM, OUT OF OR IN CONNECTION WITH THE SOFTWARE OR THE USE OR OTHER DEALINGS IN THE SOFTWARE.

Except as contained in this notice, the name of Daniel Veillard shall not be used in advertising or otherwise to promote the sale, use or other dealings in this Software without prior written authorization from him.

icu4c

ICU License - ICU 1.8.1 and later

COPYRIGHT AND PERMISSION NOTICE

Copyright (c) 1995-2012 International Business Machines Corporation and others

All rights reserved.

Permission is hereby granted, free of charge, to any person obtaining a copy of this software and associated documentation files (the "Software"), to deal in the Software without restriction, including without limitation the

rights to use, copy, modify, merge, publish, distribute, and/or sell copies of the Software, and to permit persons to whom the Software is furnished to do so, provided that the above copyright notice(s) and this permission notice appear in all copies of the Software and that both the above copyright notice(s) and this permission notice appear in supporting documentation.

THE SOFTWARE IS PROVIDED "AS IS", WITHOUT WARRANTY OF ANY KIND, EXPRESS OR IMPLIED, INCLUDING BUT NOT LIMITED TO THE WARRANTIES OF MERCHANTABILITY, FITNESS FOR A PARTICULAR PURPOSE AND NONINFRINGEMENT OF THIRD PARTY RIGHTS. IN NO EVENT SHALL THE COPYRIGHT HOLDER OR HOLDERS INCLUDED IN THIS NOTICE BE LIABLE FOR ANY CLAIM, OR ANY SPECIAL INDIRECT OR CONSEQUENTIAL DAMAGES, OR ANY DAMAGES WHATSOEVER RESULTING FROM LOSS OF USE, DATA OR PROFITS, WHETHER IN AN ACTION OF CONTRACT, NEGLIGENCE OR OTHER TORTIOUS ACTION, ARISING OUT OF OR IN CONNECTION WITH THE USE OR PERFORMANCE OF THIS SOFTWARE.

Except as contained in this notice, the name of a copyright holder shall not be used in advertising or otherwise to promote the sale, use or other dealings in this Software without prior written authorization of the copyright holder.

zlib

zlib.h -- interface of the 'zlib' general purpose compression library
version 1.2.8, April 28th, 2013

Copyright (C) 1995-2013 Jean-loup Gailly and Mark Adler

This software is provided 'as-is', without any express or implied warranty. In no event will the authors be held liable for any damages arising from the use of this software.

Permission is granted to anyone to use this software for any purpose, including commercial applications, and to alter it and redistribute it freely, subject to the following restrictions:

1. The origin of this software must not be misrepresented; you must not claim that you wrote the original software. If you use this software in a product, an acknowledgment in the product documentation would be appreciated but is not required.
2. Altered source versions must be plainly marked as such, and must not be misrepresented as being the original software.
3. This notice may not be removed or altered from any source distribution.

Jean-loup Gailly Mark Adler
jloup@gzip.org madler@alumni.caltech.edu

The data format used by the zlib library is described by RFCs (Request for Comments) 1950 to 1952 in the files <http://tools.ietf.org/html/rfc1950> (zlib format), [rfc1951](http://tools.ietf.org/html/rfc1951) (deflate format) and [rfc1952](http://tools.ietf.org/html/rfc1952) (gzip format).

LICENSE ISSUES

=====

The OpenSSL toolkit stays under a dual license, i.e. both the conditions of the OpenSSL License and the original SSLeay license apply to the toolkit. See below for the actual license texts.

OpenSSL License

```
/* =====
 * Copyright (c) 1998-2016 The OpenSSL Project. All rights reserved.
 *
 * Redistribution and use in source and binary forms, with or without
 * modification, are permitted provided that the following conditions
 * are met:
 *
 * 1. Redistributions of source code must retain the above copyright
 * notice, this list of conditions and the following disclaimer.
 *
 * 2. Redistributions in binary form must reproduce the above copyright
 * notice, this list of conditions and the following disclaimer in
 * the documentation and/or other materials provided with the
 * distribution.
 *
 * 3. All advertising materials mentioning features or use of this
 * software must display the following acknowledgment:
 * "This product includes software developed by the OpenSSL Project
 * for use in the OpenSSL Toolkit. (http://www.openssl.org/)"
 *
 * 4. The names "OpenSSL Toolkit" and "OpenSSL Project" must not be used to
 * endorse or promote products derived from this software without
 * prior written permission. For written permission, please contact
 * openssl-core@openssl.org.
 *
 * 5. Products derived from this software may not be called "OpenSSL"
 * nor may "OpenSSL" appear in their names without prior written
 * permission of the OpenSSL Project.
 *
 * 6. Redistributions of any form whatsoever must retain the following
 * acknowledgment:
 * "This product includes software developed by the OpenSSL Project
 * for use in the OpenSSL Toolkit (http://www.openssl.org/)"
 *
 * THIS SOFTWARE IS PROVIDED BY THE OpenSSL PROJECT ``AS IS'' AND ANY
 * EXPRESSED OR IMPLIED WARRANTIES, INCLUDING, BUT NOT LIMITED TO, THE
 * IMPLIED WARRANTIES OF MERCHANTABILITY AND FITNESS FOR A PARTICULAR
```

```

* PURPOSE ARE DISCLAIMED. IN NO EVENT SHALL THE OpenSSL PROJECT OR
* ITS CONTRIBUTORS BE LIABLE FOR ANY DIRECT, INDIRECT, INCIDENTAL,
* SPECIAL, EXEMPLARY, OR CONSEQUENTIAL DAMAGES (INCLUDING, BUT
* NOT LIMITED TO, PROCUREMENT OF SUBSTITUTE GOODS OR SERVICES;
* LOSS OF USE, DATA, OR PROFITS; OR BUSINESS INTERRUPTION)
* HOWEVER CAUSED AND ON ANY THEORY OF LIABILITY, WHETHER IN CONTRACT,
* STRICT LIABILITY, OR TORT (INCLUDING NEGLIGENCE OR OTHERWISE)
* ARISING IN ANY WAY OUT OF THE USE OF THIS SOFTWARE, EVEN IF ADVISED
* OF THE POSSIBILITY OF SUCH DAMAGE.
* =====
*
* This product includes cryptographic software written by Eric Young
* (eay@cryptsoft.com). This product includes software written by Tim
* Hudson (tjh@cryptsoft.com).
*
*/

```

Original SSLeay License

```

-----

/* Copyright (C) 1995-1998 Eric Young (eay@cryptsoft.com)
* All rights reserved.
*
* This package is an SSL implementation written
* by Eric Young (eay@cryptsoft.com).
* The implementation was written so as to conform with Netscapes SSL.
*
* This library is free for commercial and non-commercial use as long as
* the following conditions are aheared to. The following conditions
* apply to all code found in this distribution, be it the RC4, RSA,
* lhash, DES, etc., code; not just the SSL code. The SSL documentation
* included with this distribution is covered by the same copyright terms
* except that the holder is Tim Hudson (tjh@cryptsoft.com).
*
* Copyright remains Eric Young's, and as such any Copyright notices in
* the code are not to be removed.
* If this package is used in a product, Eric Young should be given attribution
* as the author of the parts of the library used.
* This can be in the form of a textual message at program startup or
* in documentation (online or textual) provided with the package.
*
* Redistribution and use in source and binary forms, with or without
* modification, are permitted provided that the following conditions
* are met:
* 1. Redistributions of source code must retain the copyright
* notice, this list of conditions and the following disclaimer.

```

- * 2. Redistributions in binary form must reproduce the above copyright
- * notice, this list of conditions and the following disclaimer in the
- * documentation and/or other materials provided with the distribution.
- * 3. All advertising materials mentioning features or use of this software
- * must display the following acknowledgement:
- * "This product includes cryptographic software written by
- * Eric Young (eay@cryptsoft.com)"
- * The word 'cryptographic' can be left out if the routines from the library
- * being used are not cryptographic related :-).
- * 4. If you include any Windows specific code (or a derivative thereof) from
- * the apps directory (application code) you must include an acknowledgement:
- * "This product includes software written by Tim Hudson (tjh@cryptsoft.com)"
- *
- * THIS SOFTWARE IS PROVIDED BY ERIC YOUNG ``AS IS" AND
- * ANY EXPRESS OR IMPLIED WARRANTIES, INCLUDING, BUT NOT LIMITED TO, THE
- * IMPLIED WARRANTIES OF MERCHANTABILITY AND FITNESS FOR A PARTICULAR PURPOSE
- * ARE DISCLAIMED. IN NO EVENT SHALL THE AUTHOR OR CONTRIBUTORS BE LIABLE
- * FOR ANY DIRECT, INDIRECT, INCIDENTAL, SPECIAL, EXEMPLARY, OR CONSEQUENTIAL
- * DAMAGES (INCLUDING, BUT NOT LIMITED TO, PROCUREMENT OF SUBSTITUTE GOODS
- * OR SERVICES; LOSS OF USE, DATA, OR PROFITS; OR BUSINESS INTERRUPTION)
- * HOWEVER CAUSED AND ON ANY THEORY OF LIABILITY, WHETHER IN CONTRACT, STRICT
- * LIABILITY, OR TORT (INCLUDING NEGLIGENCE OR OTHERWISE) ARISING IN ANY WAY
- * OUT OF THE USE OF THIS SOFTWARE, EVEN IF ADVISED OF THE POSSIBILITY OF
- * SUCH DAMAGE.
- *
- * The licence and distribution terms for any publically available version or
- * derivative of this code cannot be changed. i.e. this code cannot simply be
- * copied and put under another distribution licence
- * [including the GNU Public Licence.]
- */