

- 1 WIZARHAND Q1
- 2 5V Adapter
- 3 DC Cable
- 4 7.4V Lithium Battery

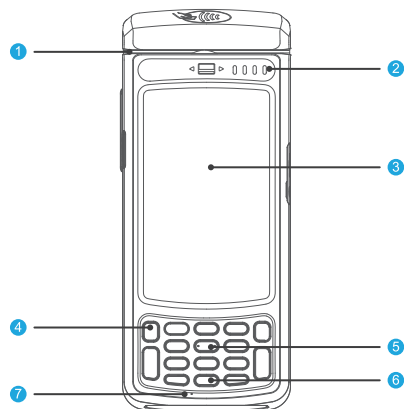

- 1 Magnetic Card Reader
- 2 4 Indicators
- 3 4" Capacitive Multi-touch Screen
- 4 Power Key
- 5 PINPAD
- 6 Scan Key
- 7 MIC

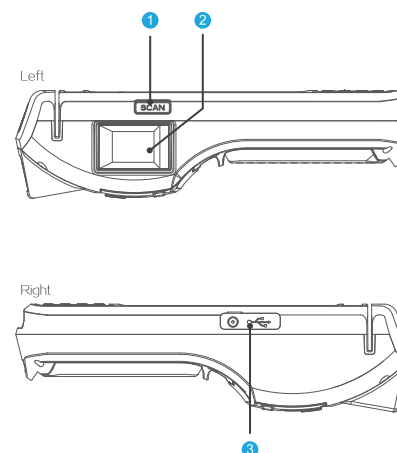

- 1 Scan Key
- 2 Fingerprint Sensor (Optional)
- 3 DC Jack & Micro-USB Port

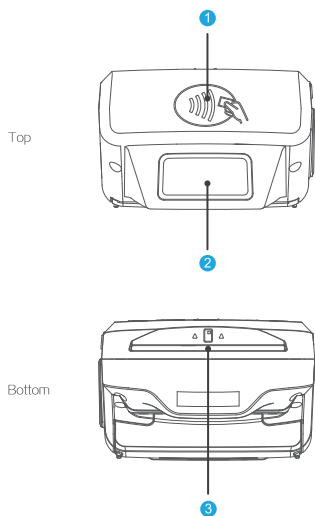

- 1 Contactless Card Reader
- 2 Barcode and 2D Barcode Scanner
- 3 IC Card Reader

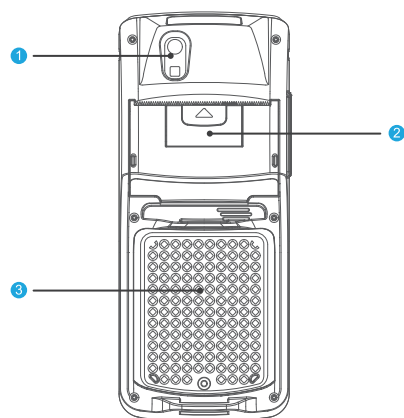

- 1 Auto-focus Camera
- 2 58mm Thermal Printer
- 3 Battery Compartment Cover

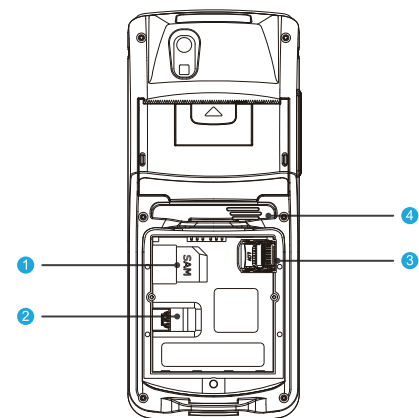

- 1 SAM Card Slot
- 2 SIM Card Slot
- 3 TF Card Slot
- 4 Speaker

WIZARHAND Q1

User Manual



www.wizarpos.com

Thank you for using the product of WizarPOS !



Certification in progress ...

1 Before use

- a) Please insert the battery first, and lock the screw on cover.
- b) Please charge if the battery has not enough power.
- c) Load the paper roll, and close the printer cover.

2 Power on and off

- a) Press "power" key for 3 seconds, you can power on the POS.
- b) After secure booting, it will display desktop, you can operate the POS.
- c) You can turn on/off the LCD by quickly press the "Power" key.
- d) When the POS is power on, press "power" key for 3 seconds, it will display the power off menu, follow the menu to power off the POS.

3 The function of keys

- a) Power key: Power on / off the POS, turn on / off LCD.
- b) Cancel key: Quit APP, cancel the password input.
- c) Backspace key: Remove the password one by one.
- d) Enter key: Enter the password.
- e) Numeric keys and Decimal point key: Key in the amount or password
- f) **SCAN**

Scan key / Side scan key: Quickly call the function of barcode scanning, needs the APP is support.

4 System setup

- a) Pull off the status bar at the top of desktop, it will display the notification interface.
- b) Click the menu icon in upper right corner of the screen, it will display the function switch interface.
- c) Click the "setup" icon, it will display the setup interface. Please setup the POS if you needed.

5 Payment operation

Please follow the instructions of your payment APP provider.

6 Bank card operation

- a) Please insert the chip card into the smart card slot with the chip end facing up.
- b) Swipe the magnetic stripe card with magnetic stripe facing to screen, you can bi-directionally swipe the card.
- c) Tap the contactless card close to the card reader area.

Product warranty policy

WizarPOS provide after-sales service according to relative laws. Please read the following warranty terms.

1. Warranty period: one year for POS and charger, and 6 months for battery cell.
2. In warranty period, wizarPOS provide free repair/replace service, if the product has non artificial product failures.
3. Welcome to call our service hotline when you needed.
4. Please show product warranty card with true information.

Warranty limitation clause

Situations due to following reasons are not covered under warranty policies.

While we can provide charge service.

1. Without our permission, the POS is maintenance by user.
2. The OS of POS is changed by user without permission from WizarPOS.
3. The trouble is caused by the third party APP which is installed by user.
4. Damage due to improper use which like falling, squeeze, hit, soaking, burning--
5. No warranty card, or cannot provide true information in card.
6. Expiry of guarantee period.
7. Exist other reason which is forbidden by laws.

Specification	Detailed Description
Software Platform	Secure Android
Processor	Quad-Core CPU
Memory	1GB RAM, 8GB Flash
Display	4" Capacitive Multi-touch Screen (480 x 800)
Printer	High Speed 58mm Thermal Printer
Camera	5M With Auto-Focus and Flash
Scanner	Barcode and 2D Barcode
Biometric	Fingerprint Sensor (Optional)
Security	PCI PTS 4.1
MSR	ISO7811 Track 1/2/3, Bi-Direction
Chip Card	ISO 7816, PBOC3.0, EMV Level 1
Contactless	ISO/IEC 14443 Type A&B, Mifare, EMV Level 1
Slots	SIM x 1, SAM x 1, TF x 1
Communication	GSM, CDMA2000, WCDMA, LTE, WiFi, Bluetooth
GPS	A-GPS, Glonass
USB	Micro-USB OTG, USB 2.0 HS Compliant
Battery	7.4V 2400mAh Lithium-ion Polymer Battery
Dimension	183 x 76 x 50 mm
Weight	450g

All features and specifications are subject to change without notice. Contact wizarPOS website for more details.
www.wizarpos.com

List of harmful substances in the product and logo of environment-friendly use period.

Part	Harmful substances					
	Pb	Hg	Cd	Cr(VI)	PBB	PBDE
LCD and TP Module	○	○	○	○	○	○
Housing and keypad	○	○	○	○	○	○
PCBA and components	×	○	○	○	○	○
Accessories	×	○	○	○	○	○

This table is made according to requirement of SJ/T 11364.
 ○ means the harmful substance concentration in the parts is under the limits in GB/T 26572.
 × means the harmful substance concentration of one or more homogeneous materials in the parts is exceeded the limits in GB/T 26572.
 NOTE: Parts which marked × are compliant to China RoHS Regulation and EU RoHS Directive.

This is environment-friendly use period logo of the product. This logo means that in this period the product will not leak harmful substances in normal usage.

Environment

- Operating temperature
-5°C~40°C (+23°F to 104°F)
- Operating humidity
20%~85% No condensation
- Storage temperature
-20°C~60°C (-4°F to 140°F)
- Storage humidity
10%~90% No condensation

Attention

- ◆ Do NOT refit the POS, that is illegal to privately refit financial POS.
- ◆ User shall bear the risks of installation and usage of third party APPs.
- ◆ The system will become slow if too many APPs installed.
- ◆ Please use dry and clean cloth to clean the POS, Do NOT use chemical.
- ◆ Do NOT expose the POS under heavy sunlight for long time.
- ◆ Do NOT use sharp and hard objects to touch the screen.
- ◆ Do NOT waste the POS, charger or battery as common household garbage. Please support recycle according to local environment rules.
- ◆ Please use the original battery and charger, otherwise that may cause product damage or personal injury.
- ◆ Do NOT put the battery into fire, otherwise it will cause explosion.
- ◆ The battery is forbidden to immerse, the battery can not be used again after entering the water.
- ◆ Do NOT short circuit battery, otherwise that will cause personal injury or battery permanent damaged.
- ◆ If battery is deformed or in abnormal heat, stop using it and replace it with new battery.
- ◆ Replacing with a wrong model battery may cause an explosion.

Trouble	Trouble shooting
Cannot connect the mobile network	<ul style="list-style-type: none"> ◆ Check whether the function of "data" is open. ◆ Check whether the APN is correct. ◆ Check whether the data service of SIM is activated.
Paper jam	<ul style="list-style-type: none"> ◆ Reload the paper roll, or check the if there is crease on paper roll. ◆ Check if the cover of printer is closed. ◆ Check whether the slot is blocked by the receipt of last transaction. ◆ Check if the print roller is missing.
Display unstable	<ul style="list-style-type: none"> ◆ The display may be interfered by instability voltage when charging, please reconnect the plug.
No response	<ul style="list-style-type: none"> ◆ Restart the APP or operation system.
Operation very slow	<ul style="list-style-type: none"> ◆ Please exit APPs which are not necessary.

Repair date	Repair content

After-Sale Service Hotline: 400-608-2601

For more information, please log on to the company's official website
 http://www.wizarpos.com

wizarPOS
 400-608-2601

